

Technical paper

Investigation of wireless electrification for a reconfigurable manufacturing cell

Hussein Mahdi ^b, Halldor Arnarson ^{a,*}, Bjørn Solvang ^a, Bernt Arild Bremdal ^c

^a Department of Industrial Engineering, UiT The Arctic University of Norway, Lovde Langesgate 2, Narvik, 8514, Nordland, Norway

^b Department of Electrical Engineering, UiT The Arctic University of Norway, Lovde Langesgate 2, Narvik, 8514, Nordland, Norway

^c Department of Computer Science and Computational Engineering, UiT The Arctic University of Norway, Lovde Langesgate 2, Narvik, 8514, Nordland, Norway

ARTICLE INFO

Keywords:

Wireless power transfer (WPT)
Battery platform
Capacitive power transfer (CPT)
Reconfigurable manufacturing system (RMS)
Industry 4.0

ABSTRACT

Reconfigurable manufacturing systems (RMS) with a rearrangeable structure can quickly adjust their productivity to meet the dynamic market changes and the demand for high-variety products. Industry 4.0 technologies have enhanced the RMS flexibility and made the automation of the reconfiguration of the manufacturing system possible. As an Industry 4.0 technology, wireless power transfer (WPT) can further increase the flexibility of RMS by providing safe, reliable, and maintenance-free autonomous charging. This paper examines the wireless electrification of RMS by investigating different WPT configurations that increase flexibility and autonomy, creating a highly flexible RMS. It also proposes a battery charging platform for further enhancement of the flexibility of RMS. As a low-cost WPT solution, the paper tests capacitive charging systems. The proposed charging system has about 135 W power transfer capability at a 5 cm distance and about 84% efficiency.

1. Introduction

Automated manufacturing systems have experienced noticeable changes passing through three main paradigms. The first paradigm is Dedicated Manufacturing System (DMS), which focuses on mass production for cost-effectiveness but with a low variation. The second paradigm is Flexible Manufacturing System (FMS) that address the production variety with low production volume. Finally, Reconfigurable Manufacturing System (RMS) is the third paradigm with high volume and high variation production combining the characteristics of the previous two paradigms. The RMS has a rearrangeable structure that can quickly adjust its productivity, variety, and flexibility based on the demand [1].

The dynamic market changes and the increasing competition between manufacturers to produce high-quality products with innovative technologies make the RMS an attractive paradigm. Bi et al. [2] proposed a systematic design methodology for RMS, including architecture, configuration, and control design. In practice, however, there is still a lack of research on how to solve design issues because a limited number of case studies are available [3]. Although the researchers have exerted considerable effort in developing RMS for several decades, there are still significant challenges, and barriers to the actual development of RMS in industry [4]. Rösiö et al. [5] explored the theoretical and practical challenges to achieving RMS design and summarized

them in three main challenges: to use a structured design methodology and gain knowledge in reconfigurability and its characteristics, and to include the reconfigurability knowledge in a structured design methodology.

For research and educational purposes, the Engineering Research Center for Reconfigurable Manufacturing Systems at the University of Michigan developed a distributed reconfigurable factory testbed [6]. Kovalenko et al. [7] proposed real and virtual environment interaction (digital twin) framework to evaluate the performance of different machines and system configurations in a mixed virtual–real environment. Zuehlke D. [8] proposed adopting the basic principle of the Internet-of-Thing (IoT) in a testbed to proof-the-concept that moving toward intelligent manufacturing is a reality. Although the researcher tried to emulate RMS using a testbed, however, these systems require human intervention to rearrange the system, which is a time-consuming process and may suffer from limited positioning.

In general, the RMS suffers from several challenges, such as it is not the complete solution to meet all of the manufacturing requirements [2]. Besides, there is still no perfect or the most realistic model and method for RMS implementation. The rearrangement of the RMS structure is also time-consuming [6]. The RMS still depends on labor to rearrange the system structure and energize the platforms, which might affect the production time and limit the flexibility of the systems. And recently, the COVID-19 pandemic has added more challenges to

* Corresponding author.

E-mail address: halldor.arnarson@uit.no (H. Arnarson).

<https://doi.org/10.1016/j.jmsy.2023.01.002>

Received 4 July 2022; Received in revised form 20 December 2022; Accepted 4 January 2023

Available online 24 February 2023

0278-6125/© 2023 The Author(s). Published by Elsevier Ltd on behalf of The Society of Manufacturing Engineers. This is an open access article under the CC BY license (<http://creativecommons.org/licenses/by/4.0/>).

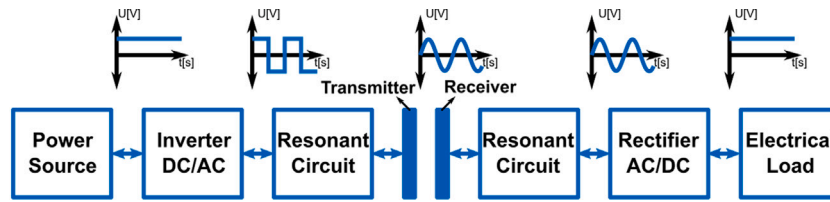

Fig. 1. An illustration of wireless electrification system.

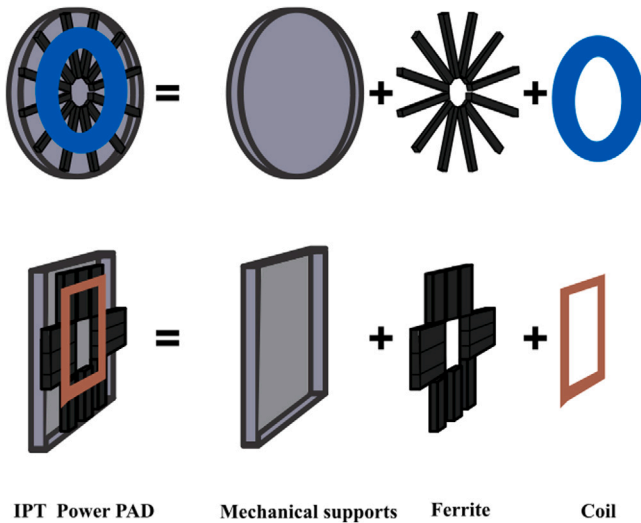

Fig. 2. An exploded view of IPT's different shape power pads.

the manufacturing systems, including lockdown and maintaining social distance [9], which can increase the rearrangement time of RMS and reduce its flexibility.

To tackle the challenges above, Arnarson et al. [10] introduced the autonomous RMS by using a mobile robot to rearrange robot arm platforms automatically to achieve flexibility and mobility. As an expansion, Arnarson et al. [11] presented a highly flexible RMS by retrofitting a number of manufacturing machines to automate the reconfiguration of the system, decrease the setup and programming time, and enhance the system's flexibility. Randanovi et al. [12] tried to solve one of the common problems of the conventional wired electrification of RMS by standardizing the connectors and plugs. In contrast, Arnarson et al. [11] considered Wireless Power Transfer (WPT) as an emerging industry 4.0 technology for electrifying RMS that tried to remove the plugs, connectors, and cables to increase the flexibility and reliability of the electrification of RMS.

The previous research on RMS investigated testbed manufacturing cells which are aimed for educational and research purposes [6–8]. Recently, researchers tried to develop a practical RMS using industry 4.0 technologies [11]. However, the proposed system still requires labor to connect the machines to electricity or charging batteries. As an industry 4.0 technology, wireless electrification can provide the required energy to these platforms without mechanical contact, similar to how IoT communication brings wireless communication. Previous research investigated wireless electrification for various applications in general and industrial robots in specific. There are also various products for robot charging applications on the market. However, the focus is more on one type of WPT, which utilizes magnetic fields.

This paper investigates the state-of-the-art WPT for robotics in manufacturing applications in the literature and on the markets. Based on the investigation, the paper proposes a novel approach to the electrification of manufacturing applications based on Capacitive Power

Table 1

A comparison between the main three groups of WPT.

	Near-field	Mid-range	Far-field
Wave	Electric/Magnetic	Magnetic	Electromagnetic
Rang	Very short (cm)	short (m)	Medium long (km)
Frequency	low high	high	Very high extreme high
Power	low moderate	Moderate	Very low
Architecture	Simple/Moderate	Complex	Complex

Transfer (CPT), which creates a new foundation for RMS that significantly increases the system's flexibility and reconfigurability. Thus, we propose and test a battery platform using CPT that utilizes electric fields to wirelessly electrify other manufacturing machines in an RMS. We can summarize the main contribution of the paper as follows:

- Investigating wireless electrification for manufacturing applications.
- Proposing an autonomous battery platform based on CPT for electrification of RMS.
- Build an RMS and demonstrate how it can be energized using wireless power transfer to increase flexibility and automation.
- Simulating, testing, and demonstrating the CPT system with the battery platform to prove the concept.

We organize the rest of this paper as follows: Section 2 presents the general concept of wireless electrification of RMS. Section 3 investigates the state-of-the-art WPT for robotics and manufacturing applications. Section 4 expands the RMS by building a battery platform that can power the system in static, dynamic, or quasi-dynamic mode. Section 5 presents the experimental and testing results of the CPT system. Section 6 gives a comprehensive discussion of WPT systems in general and CPT systems in specific. Section 7 concludes this work and presents our future works.

2. Wireless electrification

Wireless electrification, or WPT, is to transfer electric power without mechanical contact. International Telecommunication Union [13] defines WPT as “the transmission of power from a power source to an electrical load using the electromagnetic field.” The three main groups of these technologies are near-field, mid-range, and far-field [14]. The classification depends on the size of the transmitter and the receiver, and the transfer distance. Table 1 summarizes a comparison between the three main groups in terms of the type of wave, distance range, operating frequency range, power level, and system architecture.

Near-field WPT utilizes medium- to high-frequency range electromagnetic fields for high-power charging applications. Thus, the separation distance between the transmitter and the receiver is in the cm range. WPT can provide static, quasi-dynamic, and dynamic electrification [15,16]. It can also energize the system autonomously and potentially address the challenges in the conventional conductive charging approach, including long charging time, wear and tear of the connectors and plugs, and the hazard of the electric shock. Using WPT in RMS provides autonomous electrification and removes the time consumption of plugging the cables.

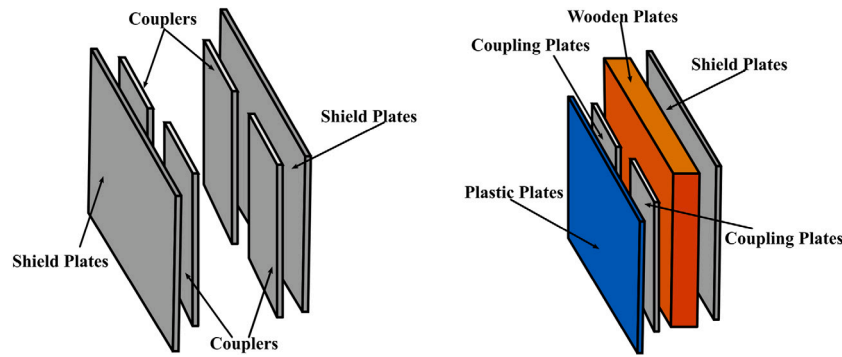

Fig. 3. Capacitive coupler: six plates CPT system (left) and an exploded view of capacitive couplers (right).

Fig. 1 illustrates the functional blocks in the WPT system. The inverter converts the DC source voltage into a square wave which depends on the operation frequency of the inverter. The resonant circuit improves the system’s overall efficiency by minimizing the reactive power, achieving soft-switching, and high misalignment tolerance. The resonant circuits also act as low-pass filters that filter out the high harmonics in the current of the inverter and reduce electromagnetic interference. Finally, the rectifier stage converts the ac resonant current into a DC. The wireless electrification system might need other DC/DC converters, for instance, between the power source and the inverter or between the rectifier and the load, which depends on the design specifications. The near-field WPT embraces three sub-group, namely, Inductive Power Transfer (IPT) and Capacitive Power Transfer (CPT).

2.1. Inductive power transfer

Inductive electrification, or IPT, operates on loosely coupled magnetic fields between transmitter and receiver coils. It includes inductive and inductive resonance. The only difference between inductive and inductive resonance is the resonance compensation circuits. The transmitter and receiver of the IPT system are also called “power pads,” composed of coils to produce alternating magnetic fields, Ferrite to align and shield the fields, and mechanical supports, as shown in Fig. 2. The Litz wire provides a solution for increasing the conductivity of the coil at high operation frequency while screening the magnetic fields. Nevertheless, both the Litz wire and the Ferrite make the pads expensive, heavy, and fragile [17]. Depending on the dimension of the power pads, the coupling and hence the efficiency of IPT systems can significantly change with the separation distance, and misalignment changes [18]. Increasing the power pads is one way to achieve better misalignment performance [19]. However, it will increase the overall system’s weight, cost, and design complexity.

2.2. Capacitive power transfer

Capacitive electrification, or CPT, utilizes alternating electrical fields that are confined between transmitter and receiver plates, also called “capacitive couplers,” to transfer power. We can build CPT systems using two-, four-, or six-plates configurations. Fig. 3 illustrates a six-plate configuration of the CPT system’s transmitter–receiver, which includes four plates forming the capacitive couplers and two plates screening the electric fields. The six plates configuration can reduce the safety clearance range from 1 m to 10 cm [20]. The transmitter and the receiver consist of aluminum capacitive couplers, plastic plates, wooden plates, and shielding plates. The plastic plates offer insulation protection, while the outer plates work as a shield to screen the leakage electric fields and offer extra protection. The wooden plates insulate the screening plates from the couplers. Based on the structure, the capacitive coupler is lighter and costs less than the IPT power pad. The CPT system is still sensitive to misalignment [20], yet it has a much better misalignment performance than the IPT system [17].

Table 2
A Comparison between IPT and CPT.

	IPT	CPT
Power Range	tens of kW	hundreds of W
Eddy Current Losses	high	low
Misalignment Performance	bad	good
Cost	high	low
Pads’/Couplers’ Weight	heavy	light
Efficiency	high	medium
Fields Shielding	complex	simple

To sum up, IPT systems contain Litz wires and magnetic screenings, which are expensive, fragile, and heavy. Besides, the magnetic fields can interact with the metal parts of the platforms resulting in high eddy losses, which can increase the temperature of the platforms. As an alternative, CPT is more suitable for the platform as it tackles the challenges that face IPT systems. Table 2 lists a comparison between IPT and CPT systems in terms of power density, losses, misalignment performance, cost, weight, and efficiency.

3. The state-of-the-art WPT for robotics in manufacturing applications

Wireless power transfer has several distinctive advantages, including reliability, flexibility, and autonomy, making it an attractive solution in many applications. More than 30 years ago, Esser and Skudelný [21] investigated wireless inductive electrification using rotatable transformers fixed on the joint of a robot. They managed to transfer 20 kW over 100 μm. About ten years later, Hirai et al. [22] proposed IPT for an autonomous decentralized manufacturing system for electrification and data transfer purposes. The proposed system transferred a consecutive 1250 GB data transmission under the continuous 2 kW power transmission over 100 μm to 500 μm to a servomotor. Since then, the research has focused more on IPT industrial robot applications. In this section, however, we focus on the most recent studies on high-power WPT for robotics in manufacturing applications and investigate the available WPT solutions on the market. Low power and data transfer are out of the scope of this paper.

3.1. Robotic arms

Wireless power transfer offers robotic arms distinct merits such as no risk of electrocution, high convenience and robustness, and water- and dust-proof [23]. Thus, wireless electrification (WPT) applications for robot arms have gained more attention. Inductive electrification (IPT) is the common approach used in robotic arms by applying magnetic connections at the joint. Han et al. [23] energized two permanent magnet dc motors in a robot arm using IPT. And they reported output power of 142.9 W at 88.7% transmission efficiency. Besides, Kikuchi et al. [24] proposed IPT to power a robot manipulator used

Table 3
Summary of WPT applications in the literature.

Ref.	Application	Power [W]	Eff. [%]	Freq. [kHz]	Dist. [mm]
[23]	Robotic Arm	142.9	88.7	85	100
[24]	Robotic Arm	311.6	92	246	5
[25]	Robotic Arm	39.9	78	6780	250
[26]	Robotic Arm	85.9	84	150	100
[28]	Logistic Robot	150	90	300	200
[30]	Transport Robot	30	74.2	100	8

in warehouse automation systems. They built a prototype with a maximum power of 311.6 W and total efficiency of 94%. Moreover, Tokano et al. [25] experimented with a 39.9 W and 78.0% power-delivery efficiency for conventional robot arms. Finally, Wu et al. [26] proposed and tested a 85.9 W multidegree freedom and bidirectional transmission capability WPT system for robot arm's joints (see Table 3).

3.2. Transport and mobile robots

For flexible manufacturing, IPT systems have found their application with clean factory automation through the dynamic powering of vehicles on monorails which have spread to floor-mounted automatic guided vehicles and other industrial vehicles [27]. Zhang et al. [28] proposed an IPT system for a logistic robot within a confined three-dimensional space around the charging station. In addition, Lee et al. [29] proposed an IPT system for continuous wireless powering of multiple transport robots in an electrified monorail system. Table 3 lists the available wireless solution in the literature.

3.3. WPT on the market

Many manufacturers are working to develop WPT technologies for robot joints of robotic arms applications. TDK [31] offers a 200 W IPT system for mobile robots that has a power distance 100 mm to 300 mm, 88% efficiency, and a 50 W IPT system for robot arms. Moreover, Waypoint Robotics [32] offers a 300 W non-contact charging and energy delivery system that ensures maximum availability of their mobile robot fleet. Delta [33] provides a 1 kW IPT system for mobile with a maximum efficiency of 93%. In addition, Wibotic [34] provides a 300 W IPT charging solution for mobile robots. Table 3 lists the WPT systems on the market for manufacturing.

Thus far, the previous research has focused more on IPT industrial robot applications and less focus on manufacturing cells. The examples in the literature and on the market only use IPT. The IPT systems comprise expensive, fragile, and heavy components, and they have high eddy losses. In contrast, CPT is more suitable for the platform as it tackles the challenges that face IPT systems. To the authors' knowledge, there has not been any investigation on CPT to power a manufacturing cell. In the next section, we propose a CPT system for the electrification of a RMS manufacturing cell.

4. RMS with battery platform

4.1. The structure of the proposed RMS

Previously, Arnarson et al. [11] proposed an RMS consisting of five platforms; two industrial robots (Scara and Nachi), a conveyor platform, a conveyor lift platform, and a 3D printing platform. The RMS can move and rearrange automatically with the help of a mobile robot in a manufacturing environment that is flexible and scalable, and it has the potential to be fully autonomous. A demonstration video [35] shows the mobile robot picking up the platforms and assembling two manufacturing layouts. In this paper, we expand the system by proposing a battery platform to increase the flexibility of the RMS (see Fig. 4).

Table 4
Power usages of the modules.

Module	Power [W]
IRB1 (Scara)	141
IRB2 (Nachi)	242
Conveyor	38
Conveyor lift	54
3D printer	350

4.2. Battery platform

In this paper, we suggest adding two extra platforms to the system, containing only batteries. While one platform is charging, the other is powering the system, as shown in Fig. 5. When the platform powering the system is running out of power, a fully-charged battery platform can replace it. The capacity of the batteries on the battery platform decides how long the platform can power the system. The mobile robot drives to pick up a full battery platform at the charging station and places it within the RMS. Then, the mobile robot picks up the empty battery platform and transports it to the charging station. Afterward, the mobile robot can do other logistics tasks. A video <https://youtu.be/o3jhAhYdPUC> demonstrates a simulation of how the battery platforms change.

The battery platform can also power other platforms in the system in the static, dynamic, or quasi-dynamic modes, as shown in Fig. 6. Thus, the mobility of the battery platform gives the system more flexibility, reconfigurability, and reliability. In addition, the battery platform can also charge the mobile robot. When the mobile robot is moving the battery platform, the battery platform can charge the mobile robot. This allows a flexible method to charge the mobile robot without the need to turn to a charging point, but it depends on the capacity of the batteries.

5. Experimental validation and testing

5.1. The power requirement

All the platforms have small computers and microcontrollers to collect data from the sensors and operate independently. For each platform, we measured the power consumption under normal operation. This means measuring the total power consumption of the computers and robots/conveyors while they are moving. Table 4 lists the power usage of all platforms under test operation conditions. The platforms require low power consumption to run the system, which ranges 43 W to 350 W. As the required power is not high, using WPT can be a flexible solution to power the system.

It should be noted that the conveyor uses only 38 W in this system since the motor uses a gearbox with a 75:1 ratio. The idea of this demonstration is to show that a manufacturing system that has low power consumption can be wirelessly powered. Each platform is equipped with batteries that can be used to supply the manufacturing platforms with power peaks as long as the power draw is not higher than from the WPT system. Large machines, such as CNC and 3D printers, consume large power, which will be a challenge to electrification wirelessly. These large machines are not reconfigurable, as they require re-calibration; hence the reconfigurable platforms are rearranged around them. Thus, we will not consider wireless electrification for these large machines.

5.2. Capacitive wireless electrification for RMS

As an inexpensive and simple solution for electrifying the RMS, we will continue investigating the CPT system. We use the same configuration shown in Fig. 3 to build the capacitive couplers. The size of the couplers is 25 × 25 cm, the wooden plate is 30 × 70 cm, and the shield plate is 25 × 70 cm. The distance between the plates on

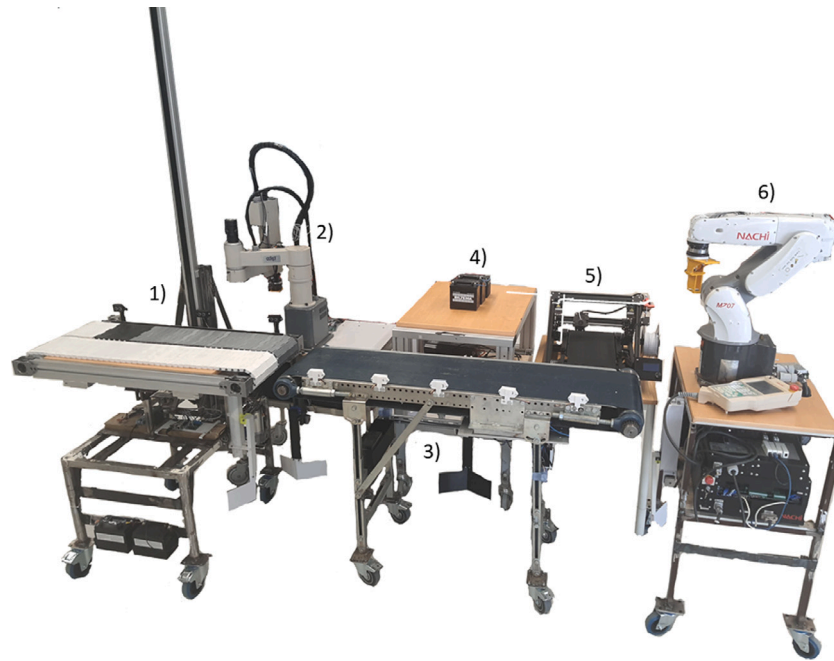

Fig. 4. The expansion of RMS with battery platform. (1) conveyor with lifting (2) Scara platform, (3) conveyor, (4) battery platform, (5) 3D printer, and (6) Nachi platform.

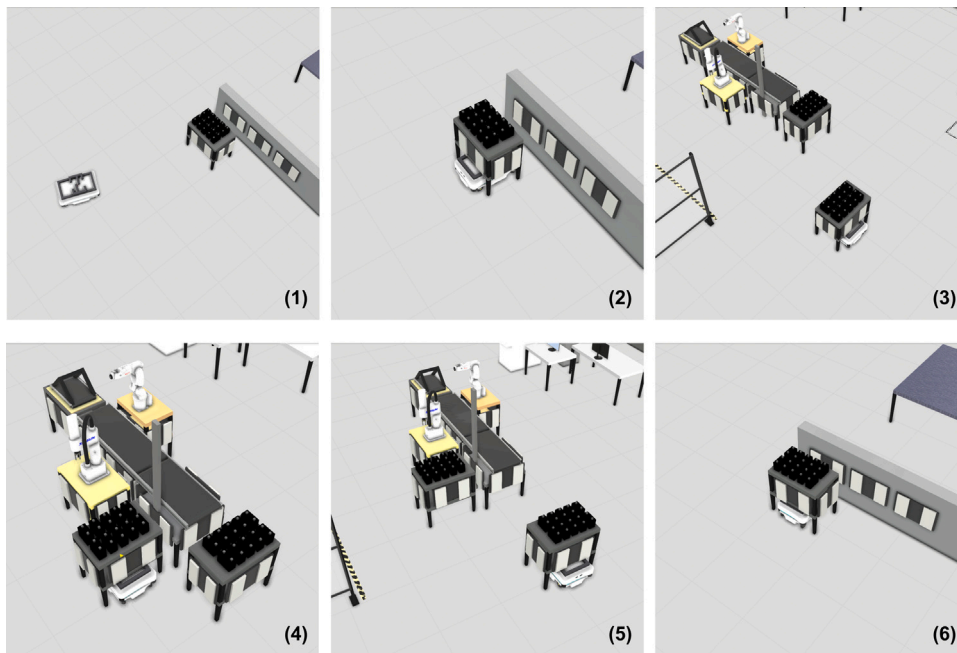

Fig. 5. The operation principle of the battery platform: The mobile robot drives to pick up a full battery platform (steps 1 to 4), picks up the empty battery platform, and transports it to the charging station (steps 5 to 6).

the same sides is 10 cm. We utilize a GaN bridge inverter (Infineon EVAL1EDFG1HBGAN [36]) and four Schottky diodes (C6D04065 A [37]) to build the rectifier bridge. We also used air-cored inductors in the series resonant circuit to compensate both transmitter and the receiver sides with the inductance of 235.1 μH for L_T and 268.3 μH for L_R .

Fig. 7 presents testing results in the laboratory. The CPT output power is about 109 W with an efficiency of about 73% at 150 V input voltage and 1.3 MHz. The maximum voltage is more than 600 V across the couplers, and the maximum current through the receiver side inductor is about 1 A. Due to the harmonics, the current is not a pure

sine waveform. This video <https://youtu.be/-mubROmWRcI> shows the testing of the CPT system.

We can further increase the output power by increasing the input voltage. To further improve the efficiency and increase the transmitting distance, we also increased the size of the coupling plates to 30 × 45 cm, and the distance between the couplers was 18 cm. The CPT output power is about 134.6 W with a total efficiency of about 84% at 1 MHz and about 5 cm distance between the transmitter and the receiver.

Fig. 8 shows the separation distance's effect on the CPT system's efficiency. The efficiency decreases with the increase of the distance, which we can attribute to the sensitivity of the compensation circuits (i.e., the resonant frequency) to the distance change. One way to

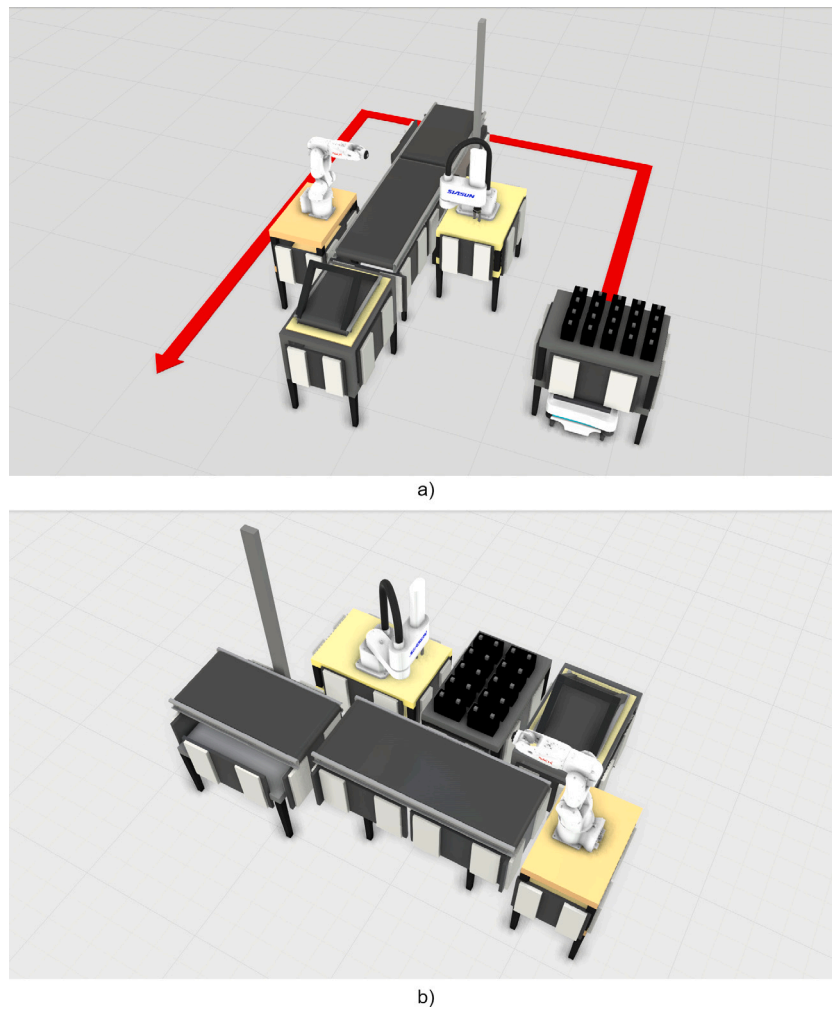

Fig. 6. The two operation modes of battery platform: (a) The dynamic mode. (b) the static mode.

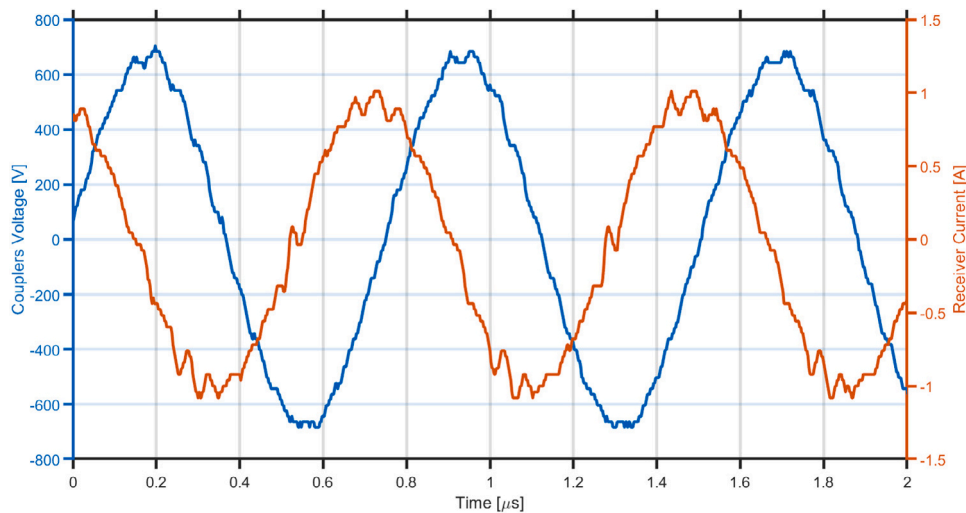

Fig. 7. The voltage across the couplers and the current on the receiver side.

enhance the efficiency is by proposing control techniques to operate the inverter at a frequency that can adapt to the change in the distance.

When the maximum output voltage of the inverter is 300 V, the voltage across the couplers can reach about 1.9kV, which is high voltage stress, as shown in Fig. 9. Fig. 10 shows the currents through

the transmitter’s and the receiver’s indicators. The transmitter’s current is about 2.2 times the amplitude higher than the receiver’s current.

To prove the concept, we designed a battery platform with three batteries connected in parallel as a power source and the CPT system transmitter plates, shown in Fig. Fig. 4. We also equipped it with

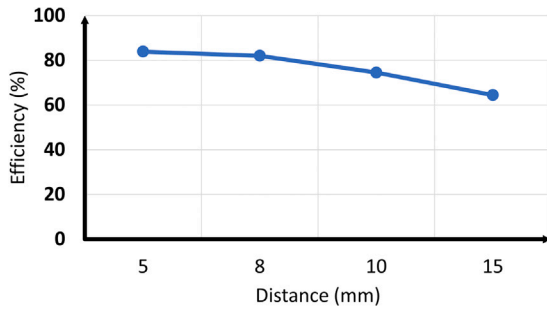

Fig. 8. The efficiency of the CPT system versus the change in the separation distance between the platforms.

a converter that steps up the 12 V input voltage to 300 V voltage to achieve the required electric field strength. Moreover, we retrofitted the conveyor platform with the receiver couplers, and the step-down converter stage converted the output voltage from 300 V to 12 V. The functional blocks of the proposed CPT system show the parts of the systems and the components that are used in each part, as shown in Fig. 11.

Fig. 12 shows the demonstration of a CPT system between two platforms. In the demonstration, the mobile robot picks up the battery platform and brings it to the other platforms. Then, the battery platform starts energizing the conveyor platform, which is not equipped with batteries. Fig. 12 and the video <https://youtu.be/KRwIdJ8fu5A> show the experiment described above.

6. Discussion

Arnarson et al. [11] tried to tackle the challenges that RMS encounters by retrofitting manufacturing machines with industry 4.0 technologies. Their system can automatically arrange five platforms using a mobile robot for manufacturing a specific product. The system is flexible and scalable and can be autonomous, but all platforms are energized with batteries, which require human intervention to charge them. Thus, there is a need for an autonomous method for charging or electrifying the platforms to make the proposed system fully autonomous.

Dealing with the charging problem, Randanovi et al. [12] tried to solve one of the common problems of the conventional wired electrification of RMS by standardizing the connectors and plugs. Another solution is to use the same principle of charging a mobile robot through electro-mechanical parts, but this solution limits the platforms' positioning and increases the need for maintenance due to the wear and tear of these contacts.

From the opposing point of view, Arnarson et al. [11] proposed WPT, which tried to remove the plugs, connectors, and cables to increase the flexibility and reliability of the electrification of RMS. They also proposed WPT as industry 4.0 technology to increase the flexibility of the manufacturing system. One of the industry 4.0 technologies is the IoT, where we can communicate wireless between machines and sensors. Similarly, we can wirelessly electrify machines and other robots, removing restrictions and making them more flexible. It was, therefore, suitable to include WPT as an industry 4.0 technology and be implemented in the following paradigms of RMS.

Using WPT, we can utilize static or dynamic WPT to electrify the system to improve its flexibility and reduce the time to reconfigure the system [11]. The dynamic WPT can electrify the platforms and the mobile robot, increasing the system's extent and cost. In contrast, static WPT offers a good option to electrify the platforms from each other or a main fixed machine. The system will get better efficiency by correcting the misalignment between the platforms.

The researchers previously investigated WPT for industrial robot electrification with power ranges from tens to hundreds of watts. On the market, there are already commercial solutions with power ranges 50 W to 300 W. However, IPT is commonly used in the literature and industrial robot applications markets. We can utilize static IPT for high power requirements of the platforms or vast distances between them. However, IPT systems contain heavy, fragile, and expensive power pads and are sensitive to misalignment and eddy losses, decreasing the overall system efficiency.

One limitation of the WPT system which proposed to RMS in [11] is that when the platforms are not connected to a wireless charging point, they need to be moved back when their battery is running low. As a novel approach to the electrification of manufacturing applications, we proposed a battery platform that can electrify other platforms of mobile robots in static, dynamic, or quasi-dynamic charging modes to increase the flexibility and reliability of the WPT charging system.

Building this platform, we increased the distance between the couplers to 5 cm and the input voltage to 300 V to achieve 134.6 W and about 84% system efficiency at 1 MHz. The proposed system demonstrated that static CPT is a low-cost alternative. However, the system's efficiency can be degraded with the increase in the distance as the system operates in an open loop. To solve this problem, we will prove a control technique that changes the operating frequency with the change in the separation distance to track the maximum efficiency of the system.

The results also showed that increasing the input voltage increases the voltage across the couplers to about 2 kV, which increases the electric fields between the plates. However, the shielding plates screen the electric fields from interacting with the platform's parts or endangering the workers near the plates. The results also show that the current on the transmitter and receiver sides have harmonics, which can have electromagnetic interference with the system. We can tackle this problem by investigating better compensation circuits to filter out the harmonics and enhance the electromagnetic compatibility of the CPT system in RMS.

Implementing the battery platform allows us to reconfigure the system in any place. Depending on the capacity of the batteries, the battery platform can charge other platforms or mobile robots in static or motion, which can further increase the flexibility and reliability of the system. For instance, the battery platform can electrify the 3D printer platform, which has the maximum power usage of 350 W, for 8 h if we connect ten batteries in parallel. The capacity of the batteries is an essential factor that decides the charging period, but increasing the capacity by adding more batteries will increase the weight of the platform resulting in a docking problem for the mobile robot, as Arnarson et al. [11] discussed.

7. Conclusion and future works

This paper investigated WPT solutions for robotics in manufacturing applications. Focuses are more on IPT industrial robot applications manufacturing cells in the literature and on the market. However, the paper presented the general concept of wireless electrification using near-field WPT technologies, namely, IPT or CPT for RMS. It also proposed and tested a static CPT system as an inexpensive and light alternative for manufacturing cells, as the proposed system comprises no expensive, fragile, or heavy parts. Utilizing a six-plates configuration, the safety clearance of the CPT system can be reduced to a few centimeters. As a novel approach to the electrification of manufacturing applications, a battery platform is designed based on the CPT system, which is a part of an RMS consisting of five other platforms: two industrial robots (Scara and Nachi), a conveyor platform, a conveyor lift platform, and a 3D printing platform. The battery platform can charge the batteries of other platforms. Hence it gives the system more flexibility, reconfigurability, and reliability. The proposed CPT system gives an output power of 135 W with 84% efficiency at 5 cm separation

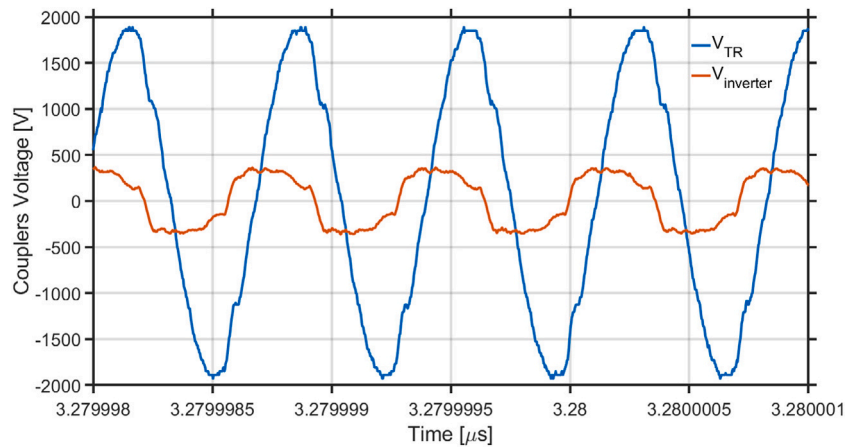

Fig. 9. The output voltage of the inverter ($V_{inverter}$) and the voltage across the couplers (V_{TR}).

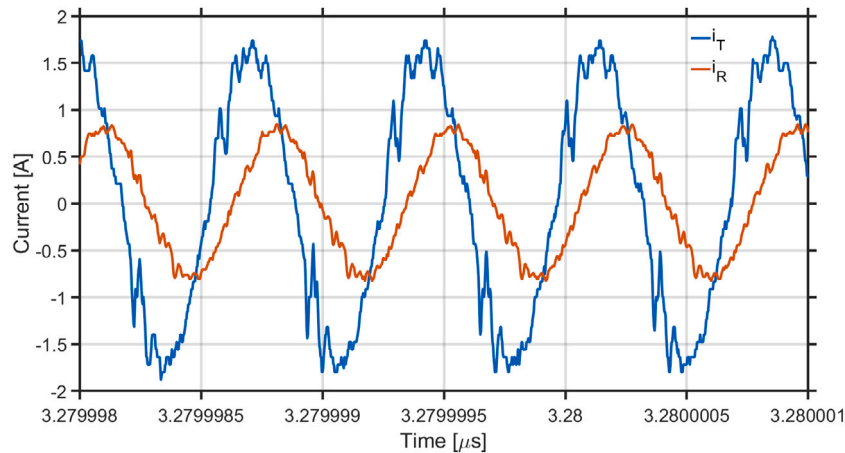

Fig. 10. The current on the transmitter side (i_T) and the receiver side (i_R).

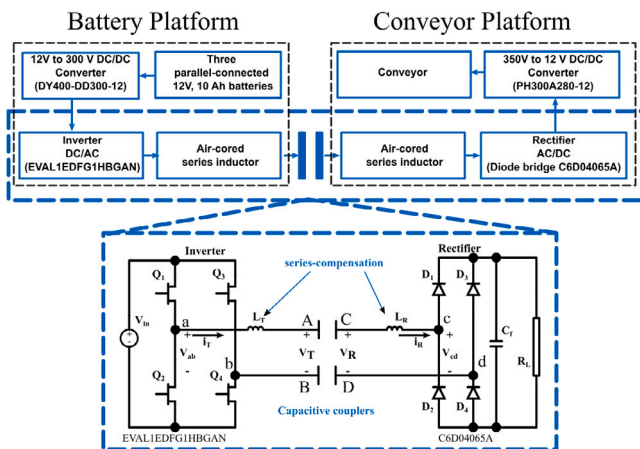

Fig. 11. The experimental setup.

distance. The efficiency decreases with the increase of the distance, which can be attributed to the sensitivity of the compensation circuits to the distance change. One way to enhance the efficiency of the system is by proposing control techniques to operate the inverter at a frequency that can adapt to the change in the distance. As further work, we will further improve the system efficiency and increase the transfer distance by proposing different resonant circuits. We will also investigate a control technique to achieve high efficiency with the variation of the separation distance.

Declaration of competing interest

The authors declare that they have no known competing financial interests or personal relationships that could have appeared to influence the work reported in this paper.

Acknowledgment

This project has received funding from the European Union’s Horizon 2020 Research and Innovation Programme under grant agreement No. 825196. All authors approved the version of the manuscript to be published.

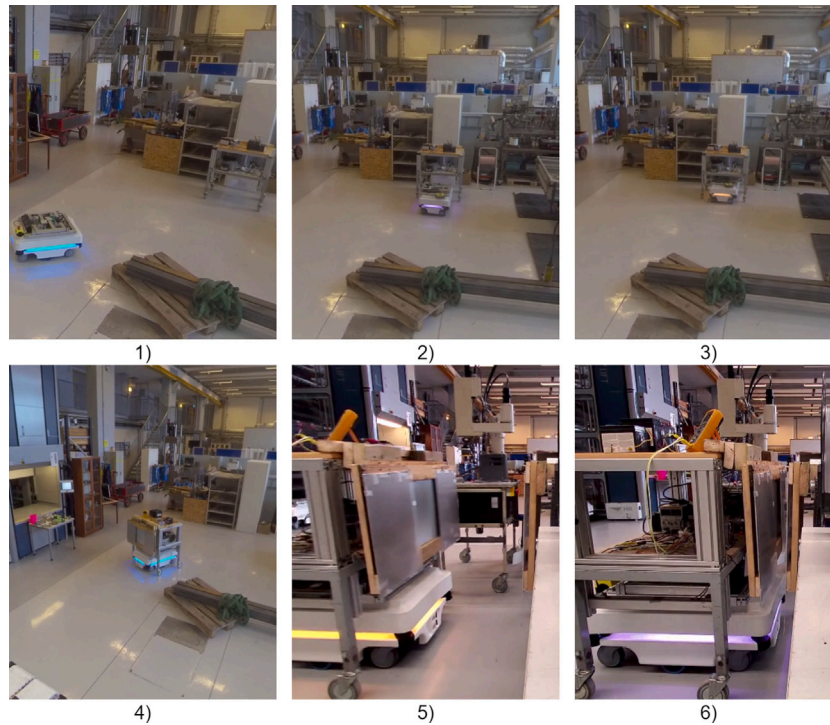

Fig. 12. Demonstration of how the CPT is implemented into the RMS: The mobile robot drives to pick up a full battery platform (step 1 to 4) and transports it to the charging RMS (step 5 to 6).

References

- [1] Koren Y, Heisel U, Jovane F, Moriwaki T, Pritschow G, Ulsoy G, et al. Reconfigurable manufacturing systems. *CIRP Ann* 1999;48(2):527–40. [http://dx.doi.org/10.1016/S0007-8506\(07\)63232-6](http://dx.doi.org/10.1016/S0007-8506(07)63232-6).
- [2] Bi ZM, Lang SYT, Shen W, Wang L. Reconfigurable manufacturing systems: the state of the art. *Int J Prod Res* 2008;46(4):967–92. <http://dx.doi.org/10.1080/00207540600905646>.
- [3] Andersen A-L, Brunoe TD, Nielsen K, Rösio C. Towards a generic design method for reconfigurable manufacturing systems: Analysis and synthesis of current design methods and evaluation of supportive tools. *J Manuf Syst* 2017;42:179–95. <http://dx.doi.org/10.1016/j.jmsy.2016.11.006>.
- [4] Andersen A-L, Nielsen K, Brunoe TD. Prerequisites and barriers for the development of reconfigurable manufacturing systems for high speed ramp-up. *Procedia CIRP* 2016;51:7–12. <http://dx.doi.org/10.1016/j.procir.2016.05.043>.
- [5] Rösio C, Säfsten K. Reconfigurable production system design – theoretical and practical challenges. *J Manuf Technol Manag* 2013;24:998–1018. <http://dx.doi.org/10.1108/JMTM-02-2012-0021>.
- [6] Kim D-Y, Park J-W, Baek S, Park KB, Kim H-R, Park J-I, et al. A modular factory testbed for the rapid reconfiguration of manufacturing systems. *J Intell Manuf* 2020;31:661–80. <http://dx.doi.org/10.1007/s10845-019-01471-2>.
- [7] Kovalenko I, Saez M, Barton K, Tilbury DM. SMART: A system-level manufacturing and automation research testbed. *Smart Sustain Manuf Syst* 2017;1:232–61. <http://dx.doi.org/10.1520/SSMS20170006>.
- [8] Zühlke D. SmartFactory - towards a factory-of-things. *Annu Rev Control* 2010;34:129–38. <http://dx.doi.org/10.1016/j.arcontrol.2010.02.008>.
- [9] Malik AA, Masood T, Kousar R. Reconfiguring and ramping-up ventilator production in the face of COVID-19: Can robots help? *J Manuf Syst* 2021;60:864–75.
- [10] Arnarson H, Solvang B. Reconfigurable autonomous industrial mobile manipulator system. In: 2022 IEEE/SICE international symposium on system integration. 2022, p. 772–7. <http://dx.doi.org/10.1109/SII52469.2022.9708887>.
- [11] Arnarson H, Mahdi H, Solvang B, Bremdal BA. Towards automatic configuration and programming of a manufacturing cell. *J Manuf Syst* 2022;64:225–35. <http://dx.doi.org/10.1016/j.jmsy.2022.06.005>.
- [12] Radanović P, Jereb J, Kovač I, Ude A. Design of a modular robotic workcell platform enabled by plug & produce connectors. In: 2021 20th international conference on advanced robotics. ICAR, 2021, p. 304–9. <http://dx.doi.org/10.1109/ICAR53236.2021.9659345>.
- [13] ITU-R Recommendation ITU-R SM2110. Frequency ranges for operation of non-beam wireless power transmission systems. 2017, Available at <https://www.itu.int/rec/R-REC-SM.2110-0-201709-S> (2021/11/09).
- [14] Alicia T-C, José M G-G, José A A. *Wireless power transfer for electric vehicles: Foundations and design approach*. 1st ed. Springer International Publishing; Imprint: Springer; 2020.
- [15] Ahmad A, Alam MS, Chabaan R. A comprehensive review of wireless charging technologies for electric vehicles. *IEEE Trans Transp Electr* 2018;4(1):38–63. <http://dx.doi.org/10.1109/TTE.2017.2771619>.
- [16] Liu W, Chau KT, Lee CHT, Han W, Tian X, Lam WH. Full-range soft-switching pulse frequency modulated wireless power transfer. *IEEE Trans Power Electron* 2020;35(6):6533–47. <http://dx.doi.org/10.1109/TPEL.2019.2952573>.
- [17] Lu F, Zhang H, Mi C. A review on the recent development of capacitive wireless power transfer technology. *Energies* 2017;10(11). <http://dx.doi.org/10.3390/en10111752>, URL <https://www.mdpi.com/1996-1073/10/11/1752>.
- [18] Zheng C, Ma H, Lai J-S, Zhang L. Design considerations to reduce gap variation and misalignment effects for the inductive power transfer system. *IEEE Trans Power Electron* 2015;30(11):6108–19. <http://dx.doi.org/10.1109/TPEL.2015.2424893>.
- [19] Hossain A, Darvish P, Mekhilef S, Tey KS, Tong CW. A new coil structure of dual transmitters and dual receivers with integrated decoupling coils for increasing power transfer and misalignment tolerance of wireless EV charging system. *IEEE Trans Ind Electron* 2022;69(8):7869–78. <http://dx.doi.org/10.1109/TIE.2021.3108697>.
- [20] Zhang H, Lu F, Hofmann H, Liu W, Mi CC. Six-plate capacitive coupler to reduce electric field emission in large air-gap capacitive power transfer. *IEEE Trans Power Electron* 2018;33(1):665–75. <http://dx.doi.org/10.1109/TPEL.2017.2662583>.
- [21] Esser A, Skudelny H-C. A new approach to power supplies for robots. *IEEE Trans Ind Appl* 1991;27(5):872–5. <http://dx.doi.org/10.1109/28.90341>.
- [22] Hirai J, Kim T-W, Kawamura A. Practical study on wireless transmission of power and information for autonomous decentralized manufacturing system. *IEEE Trans Ind Electron* 1999;46(2):349–59. <http://dx.doi.org/10.1109/41.753774>.
- [23] Han W, Chau KT, Hua Z, Pang H. Compact wireless motor drive using orthogonal bipolar coils for coordinated operation of robotic arms. *IEEE Trans Magn* 2022;58(2):1–8. <http://dx.doi.org/10.1109/TMAG.2021.3082018>.
- [24] Kikuchi S, Sakata T, Takahashi E, Kanno H. Development of wireless power transfer system for robot arm with rotary and linear movement. In: 2016 IEEE international conference on advanced intelligent mechatronics. 2016, p. 1616–21. <http://dx.doi.org/10.1109/AIM.2016.7577001>.
- [25] Tokano K, Zhu W, Osato T, Nguyen K, Sekiya H. Optimal design of 6.78 MHz wireless power transfer system for robot arm. In: 2021 IEEE international symposium on circuits and systems. 2021, p. 1–5. <http://dx.doi.org/10.1109/ISCASS1556.2021.9401073>.

- [26] Wu J, Dai X, Gao R, Jiang J. A coupling mechanism with multidegree freedom for bidirectional multistage WPT system. *IEEE Trans Power Electron* 2021;36(2):1376–87. <http://dx.doi.org/10.1109/TPEL.2020.3010955>.
- [27] Covic GA, Boys JT. Inductive power transfer. *Proc IEEE* 2013;101(6):1276–89. <http://dx.doi.org/10.1109/JPROC.2013.2244536>.
- [28] Zhang Z, Zhang B. Omnidirectional and efficient wireless power transfer system for logistic robots. *IEEE Access* 2020;8:13683–93. <http://dx.doi.org/10.1109/ACCESS.2020.2966225>.
- [29] Lee ES, Kim MY, Kang SM, Han SH. Segmented IPT coil design for continuous multiple charging of an electrified monorail system. *IEEE Trans Power Electron* 2022;37(3):3636–49. <http://dx.doi.org/10.1109/TPEL.2021.3115511>.
- [30] Zhang Y, Yang J, Jiang D, Li D, Qu R. Design, manufacture, and test of a rotary transformer for contactless power transfer system. *IEEE Trans Magn* 2022;58(2):1–6. <http://dx.doi.org/10.1109/TMAG.2021.3094135>.
- [31] TDKCo. Magnetic resonance method of wireless power transfer technology for industrial equipment. 2022, URL <https://product.tdk.com/en/techlibrary/developing/wireless/index.html>. [Online; Accessed 25 May 2022].
- [32] Waypoint Robotics. EnZone™ — Wireless charging and energy on demand. 2022, URL <https://waypointrobotics.com/enzone-wireless-power-system/>. [Online; Accessed 25 May 2022].
- [33] Delta Co. MOOVair 1 kW wireless charging system. 2022, URL <https://www.deltaww.com/en-US/products/Industrial-Battery-Charging/5776>. [Online; Accessed 25 May 2022].
- [34] GaN system. WiBotic autonomous charging. 2022, URL <https://gansystems.com/gan-applications/wibotic-300-w-wireless-power-system/>. [Online; Accessed 25 May 2022].
- [35] Arnarson H. Super flexible reconfigurable manufacturing system (5x speed). 2022, URL <https://youtu.be/UXUlaawd8Ps>. [Online; Accessed 21 Feb 2022].
- [36] CoolGaN. High-frequency half-bridge evaluation board featuring EiceDRIVER™ GaN. 2022, URL https://www.infineon.com/cms/en/product/evaluation-boards/eval_1edf_g1b_hb_gan/. [Online; Accessed 25 May 2022].
- [37] Wolfspeed. Silicon Carbide Schottky Diode. 2022, URL <https://assets.wolfspeed.com/uploads/2020/12/C6D04065A.pdf>. [Online; Accessed 25 May 2022].