



UiT The Arctic University of Norway

Faculty of Engineering Science and Technology (IVT)

Development of a Jig for CMM Measurements on AutoStore Bins

Master's thesis, Engineering Design

Ida J. T. Bjørhovde

END-3900, V 2023

Abstract

The AutoStore Bins are highly technical plastic products manufactured with injection moulding. To ensure the production parameters are within given specifications, CMM scanning is done on samples from the production.

To fulfil the company's specifications and guidelines, measurements need to be taken around the Bin, extracted with CMM equipment. Today's internal setup does not fulfil the specifications, and challenges both the time consumption (two scans instead of one) and the ergonomics for the scanning operators.

This master's thesis project searches for a solution to the problem by developing a new measuring jig. The product is developed with the existing Bin designs in focus. Important customer attributes are followed to ensure that the product meet the expectations from the users. There are no current existing solutions on the market, as the AutoStore Bin is a tailor-made product. This project presents different alternatives and solution concepts, where the final solution is supported with analysis, technical drawings and datasheets.

Acknowledgements

The master's thesis is written for the scanning operators at AutoStore in mind. The new "Bin measuring jig" contributes to better working conditions by ensuring an easier and ergonomic work environment.

I would like to state gratitude and acknowledge the support, input and guidance provided by the supervisors from the university; Prof. Annette Meidell and Prof. Guy Beerli Mauseth.

The master's thesis is written for the R&D Bin team within AutoStore. I would like to state gratitude towards the external supervisor; Uwe Grünbeck, who generously provided knowledge and expertise.

I appreciate my husband, Torvald Bjørhovde, for support and motivation throughout the study programme. Our child, Elias, was given birth in December 2022 and challenged the work with the master's thesis. However, with tremendous help from my husband, it was possible to focus on the thesis work throughout the semester.

This master's thesis report concludes my two year master's programme in Engineering Design with a M.Sc. title. The education has been challenging, yet awarding.

Table of Contents

Abstract	i
Acknowledgements	ii
1 Introduction	1
1.1 Problem Description	1
1.2 Objectives	3
1.3 Limitations	3
1.4 Goal Setting	3
1.5 Motivation	3
1.6 Similar solutions	4
2 Literature Study	5
2.1 AutoStore	5
2.2 AutoStore Bins	6
2.3 Interaction Between Bins and AutoStore	7
2.3.1 Interaction With Grid	7
2.3.2 Robot ↔ Bin	8
2.3.3 Interaction with Port	9
2.4 CMM – Coordinate Measuring Machine	9
2.4.1 Portable Measuring Arm	10
2.4.2 Setup at AutoStore Test Lab	10
2.5 Jig	11
2.6 Standards and Guidelines	11
2.7 Measurements and Tolerances	11
2.7.1 Indexing	12
2.7.2 Surface Measurements	12

2.7.3	Tolerances	13
2.7.4	Measurements.....	14
3	Method	16
3.1	Clarification of Objectives.....	16
3.2	Specifications and Requirements.....	17
3.2.1	Specifications for Measuring Jig.....	17
3.2.2	Available Work Space Area	19
3.3	Determining Characteristics	20
3.4	Generating Alternatives	22
3.4.1	Category A – Height Adjustments	23
3.4.2	Category B – Bin Fitment Plate	24
3.4.3	Category C – Placement of Measuring Jig.....	25
3.4.4	Category D – Assembly System.....	26
3.4.5	Category E – Operation of Jig.....	27
3.4.6	Morphological chart	28
3.5	Evaluating Alternatives	28
3.6	Detailed Solution	31
3.6.1	Manual Version	33
3.6.2	Electric Version.....	34
3.6.3	Choice of Version.....	35
3.6.4	Detailing	35
4	Analysis.....	37
4.1	Material.....	37
4.1.1	Design Requirements	37
4.1.2	Derive Material Index	38
4.1.3	Find Materials by Properties	39

4.1.4	Find Materials by Component Definition	40
4.1.5	Choice of Material.....	42
4.2	Geometric Variations.....	42
4.3	Stress Analysis.....	43
5	Final Product	46
6	Discussion and Further Work.....	48
6.1	Discussion.....	48
6.1.1	How do the results correspond with the problem description?	48
6.1.2	Compared with similar solutions or other setups	48
6.1.3	Evaluation of reliability and validity.....	48
6.2	Further Work	49
6.2.1	Required Further Work	49
6.2.2	Alignment Brackets.....	49
6.2.3	Manual Version	49
7	Conclusion.....	50
	References	1
	Attachments.....	1

List of Tables

Table 1 - Bin specifications (AutoStore, 2023).....	6
Table 2 – Specifications and requirements for the measuring jig	17
Table 3 - Alternatives, height adjustments.....	23
Table 4 - Alternatives, Bin fitment plate.....	24
Table 5 - Alternatives, placement of measuring jig	25
Table 6 - Alternatives, assembly system.....	26
Table 7 - Alternatives, operation of jig	27
Table 8 - Morphological chart – solutions	28

Table 9 - Objectives weight factor	29
Table 10 – Morphological chart of solution concepts	29
Table 11 - Solution concepts	30
Table 12 - Weighted solution concepts	31
Table 13 – Characters, categories D & E	32
Table 14 - BMJ manual, pros and cons	34
Table 15 - BMJ electric, pros and cons	35
Table 16 - Design requirements of plates.....	37
Table 17 - Mechanical properties, Aluminium 5083	42
Table 18 - Shape suggestions, plates.....	43
Table 19 – Parameters stress analysis	43
Table 20 - Results stress analysis	44
Table 21 - Baseplate thickness iteration results with H-shape load scenario.....	45

List of Figures

Figure 1 - Collage of a-scan setup; front-, left-, and top views of 330 Bin	2
Figure 2 – Collage of b-scan setup; front-, left-, and top views of 330 Bin.....	2
Figure 3 - AutoStore system (bins, 2021)	5
Figure 4 - AutoStore Bins: 220, 330 & 425	6
Figure 5 - Grid and Bins (U. Grünbeck, personal communication, January 2022)	8
Figure 6 - Robot handling of Bins (AutoStore, 2023).....	8
Figure 7 - Carousel and Pick-up ports (AutoStore, 2023).....	9
Figure 8 - CMM setup at AutoStore's test lab	10
Figure 9 - Index overview (ANO-BIN-102, 2021, p.5)	12
Figure 10 - Example H1 (ANO-BIN-102, 2021, p. 10)	12
Figure 11 - Example Flatness (ANO-BIN-102, 2021, p. 9).....	13
Figure 12 - Tolerances (DIN 16742:2013-10)	13
Figure 13 - Measurements seen on 425 Bin, 3D view	14
Figure 14 - Measurements seen on 425 Bin, bottom view.....	15
Figure 15 - Measurements seen on 425 Bin, front and right-views	15
Figure 16 - Measurements seen on 425 Bin, top view	15
Figure 17 - Objective tree for the measuring jig	17

Figure 18 - Arm reach, seen from right. A total height reach of 1300mm, where the 900mm reach represents the height reach when the arm is extracted maximum in length/width. 1000mm and 300mm represents the arm reach in height from the base on the table. 19

Figure 19 - Arm reach, seen from top – with the Bin from Figure 13 for scale. 20

Figure 20 - Arm reach, seen from front – with the Bin from Figure 13 for scale..... 20

Figure 21 - Description of "House of Quality" matrix (Mauseth, 2022, p. 63) 21

Figure 22 - Determining characteristics - HoQ matrix. Items 8 & 9 from Figure 21 is not applicable. 21

Figure 23 - Generating alternatives, parts and categories 22

Figure 24 – Pipe-in-pipe with lock pin, zig-zag lock and threads..... 23

Figure 25 - Angle adjustment with support leg..... 23

Figure 26 - Angle adjustment with rotating lock 23

Figure 27 - Linear guideway with a ball runner block (Bosch Rexroth, 2023) 23

Figure 28 – Bin fitment plate with locks..... 24

Figure 29 – Bin fitment plate with surface treatment..... 24

Figure 30 – Bin fitment plate with structured fitment..... 24

Figure 31 - Placement on granite tabletop 25

Figure 32 - Jig attached to granite table 25

Figure 33 - Hexagon MST36 Portable Precision Tripod (Hexagon, 2022, p.43) 25

Figure 34 - U-shaped table (AJ Produkter, 2023) 26

Figure 35 - Rexroth parts (Bosch Rexroth, 2023) 26

Figure 36 – Clamping lever (Bosch Rexroth, 2023) 27

Figure 37 – Electric linear guideway (THK, 2023) 27

Figure 38 – Hydraulic jack (Maxtech, 2022) 27

Figure 39 - Electro-mechanical lifting cylinder (Bosch Rexroth, 2023)..... 27

Figure 40 - Concept 1 30

Figure 41 - Concept 2..... 30

Figure 42 - Concept 3..... 30

Figure 43 - Concept 4..... 31

Figure 44 - Bin Measuring Jig, manual version 33

Figure 45 - Bin Measuring Jig, electric version 34

Figure 56 – Baseplates, X-shaped and H-/O-shaped 35

Figure 46 - Alignment bracket, 3D model and placement in assembly	36
Figure 47 - Holding bracket; 3D model and placement in assembly (highlighted in orange) .	36
Figure 48 - Material selection chart, first five results are named on chart (GrantaEduPack)..	39
Figure 49 - Passed materials ranked by index, first 10 results (Granta EduPack)	40
Figure 50 - Material selection mass/stiffness chart, the different materials on top are named (Granta EduPack)	41
Figure 51 - Results passed materials ranked by mass/stiffness, first 15 results (Granta EduPack)	41
Figure 52 - Inventor materials	42
Figure 53 - Bin fitment plate, X-shaped.....	43
Figure 54 - Bin fitment plate, H-shaped.....	43
Figure 55 - Bin fitment plate, 0-shaped.....	43
Figure 57 - Load (yellow arrows) and constraints (red areas) on Baseplate and X-shaped Bin fitment plate.....	44
Figure 58 - Results H-shape; Von Mises stress and displacement.....	44
Figure 59 - Results H-shape on baseplate; Von Mises stress and displacement.....	45
Figure 60 - Bin fitment plate and baseplate, mesh 0.005, results displacement	45
Figure 61 - Final product, 3D view, front- and right views	46
Figure 62 - Final product, top- and bottom views.....	47
Figure 63 - BMJ placed within the reach of the measuring arm, front view. The jig is height adjusted 200mm and has a 425 Bin attached.	47

1 Introduction

In product assemblies, the tolerances play a huge role of the functionality. For a warehouse system like AutoStore, there are different parts working together. Each product has high demands in tolerances and accuracy. For these types of parts and products, it is crucial that the products meet their requirements during production and assemblies. Measurements is one way of securing and checking the tolerances.

There are several ways of measuring parts; manual, fully automatized or a combination of both. In any cases, equipment is needed. Coordinate measuring machines, CMM's, are often used for the purposes described above. CMM measurements are reliable, repeatable and provide many possibilities.

In AutoStore, CMM is used to measure several products. For this project, the focus will be on the plastic storage boxes, called "Bins". The Bins are interacting with most parts of the AutoStore system, and it is therefore of high importance that the measurements are within their tolerances.

When scanning with AutoStore's CMM equipment, the part/assembly to be scanned need to stay still to avoid errors during the scan. It is in the interest, that all measurements can be extracted from one scan. This is the challenge for this master's project.

1.1 Problem Description

There are a lot of measurements taken around the Bin, and some of these cause challenges with today's setup. These challenges need to be solved to fulfil AutoStore's own specifications. Today, two different scans are made for each Bin, one where the Bin is placed on a granite table with the bottom staying on the table surface (a-scan), and one where the bin is turned upside down (b-scan). This causes challenges with some height measurements as well as report generating (two different reports are made). It generates therefore more work than necessary. The optimal result would consist of a solution, where all measurements are taken in one scan, generating one report. However, there are challenges with this, and some exceptions can be made. Collages of today's setup can be seen in Figure 1 and Figure 2.



Figure 1 - Collage of a-scan setup; front-, left-, and top views of 330 Bin



Figure 2 – Collage of b-scan setup; front-, left-, and top views of 330 Bin

1.2 Objectives

The project shall focus on an optimal solution, where all measurements are measured in one scan. This will reduce the amount of data stored and will be a more efficient way to scan a Bin sample. Preferably an internal jig needs to be made, which can fulfil all related requirements. The internal jig should be designed as a prototype to start with, where adjustments to a final design can be done after testing and verification.

There might be challenges with connecting all measurements in one scan, and therefore, an optimization of today's setup might be an alternative. The optimization shall focus on scanning all measurements in two scans (a smaller jig for the b-scan might be a solution) and generate one report from the two scans.

The equipment and solutions need to be tested and validated before they can be implemented. The research and work done may lead to updates of procedures, guidelines, and/or the scan program itself.

1.3 Limitations

The following limitations are formulated to evaluate the solution to the problem:

- Expecting a good working first revision – The jig do not need to be “sales-ready”,
- Simple design regarding manufacturing,
- The jig is targeted to fit existing bin designs,
- The jig may be fixed to the granite table – shall be within the reach of the measuring arm,
- The jig shall be ergonomic, safe, and easy to use.

1.4 Goal Setting

The goal is to design a functional measuring jig for AutoStore Bin measurements with CMM equipment. The project shall focus on the limitations given to ensure a good working jig.

1.5 Motivation

The extra work generated by having two scans are unnecessary when the problem can be solved by creating a measuring jig. It is motivating to reduce time and cost, and to generate a better ergonomic solution for the operators.

1.6 Similar Solutions

Today, two profiles are attached to the granite table to make a b-scan. However, there are still measurements missing. Today's solution is therefore not good enough, and a better solution need to be developed.

There are no other existing solutions on the market that fit the Bins, as the AutoStore Bins are tailormade for its use.

2 Literature Study

2.1 AutoStore

AutoStore is an efficient AS/RS system - Automatic Storage and Retrieval System, made as a dense cube. The density of the system allows the system to quadruple within an existing warehouse without the need for more floor space. The layout of AutoStore can be customized to each customer to fit their needs and available space. However, the system is based on the five standard modules, these are: (AutoStore, 2023)

- **Grid:** The structure of the cube. Consist of aluminium parts and is built on a flat floor. Keeps the bins in place and have railways for the robots. Available in two configurations, Single-Double Grid (SDG) and Double-Double Grid (DDG).
- **Bins:** The storage units. The bins are stacked on top of each other with a footprint of 649x449 mm. It is possible to subdivide the bin into different compartments. Available in three different heights; 220, 330 and 425 mm.
- **Robots:** The main workers. Drive on top of the grid to dig and collect bins. Three different robots are available: R5, R5+, and B1.
- **Ports:** The workstations. Connected to the grid but stays on the outside. This is where warehouse operators work with order fulfilment and restocking. There are five different ports available: ConveyorPort, CarouselPort, SwingPort, RelayPort, and PickUpPort.
- **Controller:** The brain of AutoStore. Controls robot traffic, bin placements, and ports. Keeps track of everything and is easily accessible to service personnel.

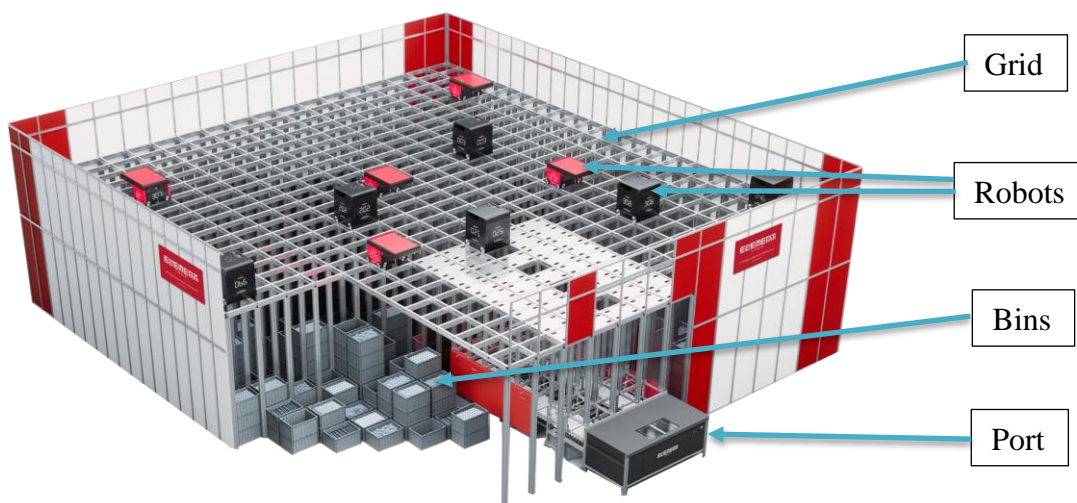

Figure 3 - AutoStore system (bins, 2021)

2.2 AutoStore Bins

The Bins comes in three different sizes, see Figure 4, and are made by injection moulding with known thermoplastics materials. A general list of specifications is given in Table 1. The Bin is a sturdy box, designed to be stacked on top of each other inside the grid. They are not nestable or foldable, which means a higher transport volume and cost. Therefore, certified production partners manufacture the Bins as close as possible to the end customers to keep the transportation cost as low as possible. Bins are the only module that interact with every other physical module. The loading and handling scenarios set high demands in production quality and product performance.

To make sure the Bin does not exceed its limits, samples of the production are sent to AutoStore’s test lab in Nedre Vats/Norway, where they will be taken through different product quality assurance processes. In addition, metrology studies will be performed to observe and measure the Bin sample’s condition. The test requirements are set by the functionalities of the AutoStore System.

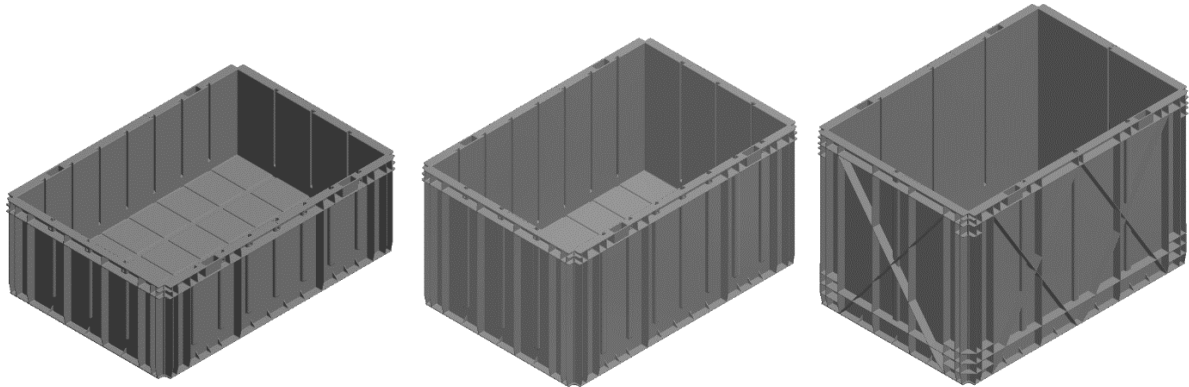

Figure 4 - AutoStore Bins: 220, 330 & 425

Table 1 - Bin specifications (AutoStore, 2023)

Specification	Value
Outside dimensions (L x W x H)	220 bin: 649 x 449 x 220 [mm] 330 bin: 649 x 449 x 330 [mm] 425 bin: 649 x 449 x 425 [mm]
Inside dimensions (L x W x H)	220 bin: 603 x 403 x 202 [mm] 330 bin: 603 x 403 x 312 [mm] 425 bin: 603 x 403 x 404 [mm]

Tolerances	Length: $\pm 2\text{ mm}$ Width: $\pm 2\text{ mm}$ Height: $\pm 1\text{ mm}$
Weight limit (all bins)	30 kg
Operating temperature (inside AutoStore system)	+2°C - +35°C
Compartments	220 bin: 32 330 bin: 32 425 bin: 8
Maximum stack storage	220 bin: 24 330 bin: 16 425 bin: 14
Available materials (all bins)	HDPE, PP-C, PP-ESD
Design of outer support ribs	220 bin: Vertical 330 bin: Vertical 425 bin: Vertical and X-shaped, plus additional horizontal rib at bottom
Design of outer corners	220 bin: Standard 330 bin: Standard 425 bin: Reinforced corners with additional ribs on bottom (3 extra ribs) and upper (1 extra rib)

2.3 Interaction Between Bins and AutoStore

2.3.1 Interaction with Grid

The grid consist of aluminium parts and is built in columns with a track for the robots on top. The Bins have space in width and length to expand while staying below the top. However, they need to pass the top frame when the robots dig them up, or place them. The top frame, where the robot track is, has a small passage for the Bins. With nominal measurements, the system tolerance has a clearance of maximum 3 mm on each side of the Bin, see Figure 5. If both the Bin and the grid are in outer tolerance zone, there is a possibility for system stop as

the Bin will not pass the top frame. Therefore, it is crucial that the Bin is within its specifications.

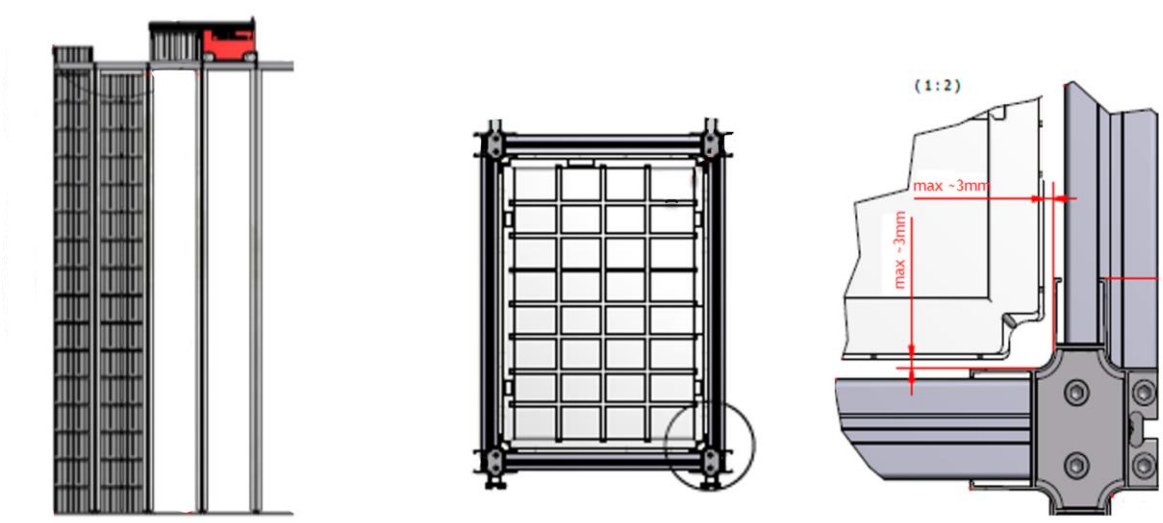

Figure 5 - Grid and Bins (U. Grünbeck, personal communication, January 2022)

2.3.2 Interaction with Robot

The robots task is to move Bins to and from the ports, and is therefore interacting directly with the Bins. All robots have more or less the same design and technology to interact with the Bins; They have a “gripper plate” which gets lowered from the robot. Attached to the gripper plate there are corner guides which will enter on the corners of the Bins to guide the plate to the centre of the bin. The grippers will thereafter enter the gripper holes to lift the Bin, see Figure 6. The corners and the gripper holes of the Bins are therefore important interaction points for the robots.

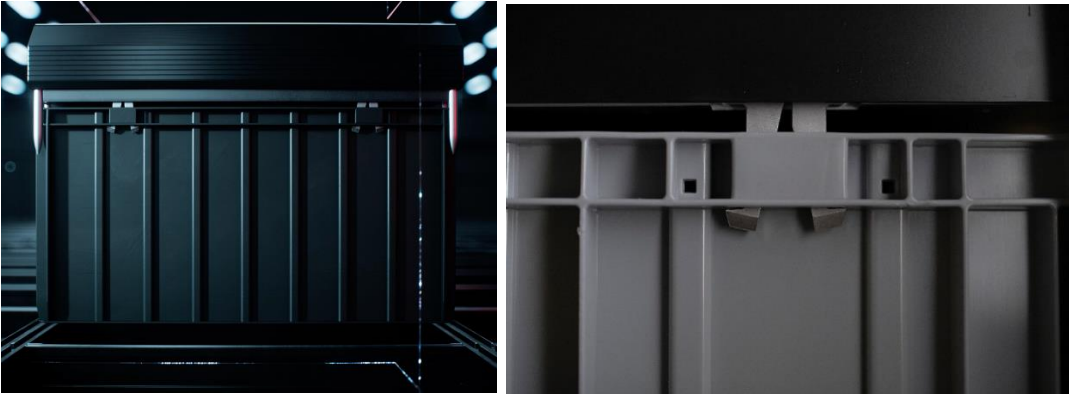

Figure 6 - Robot handling of Bins (AutoStore, 2023)

2.3.3 Interaction with Port

The robots deliver Bins to the different ports, which has different solutions for how the Bins are presented to the operators. However, all ports receive the Bin with bottom first. The bottom need to fit within the limits of the port solution, whether the interaction point is a tray, a conveyor or a frame. The limits of the different solutions are not as strict as for the grid. However, when more weight is added to the Bin in a port, there is a possibility that the Bin may expand. A Bin that is close to or out of specification, can thereafter cause trouble with system stops inside the AutoStore.

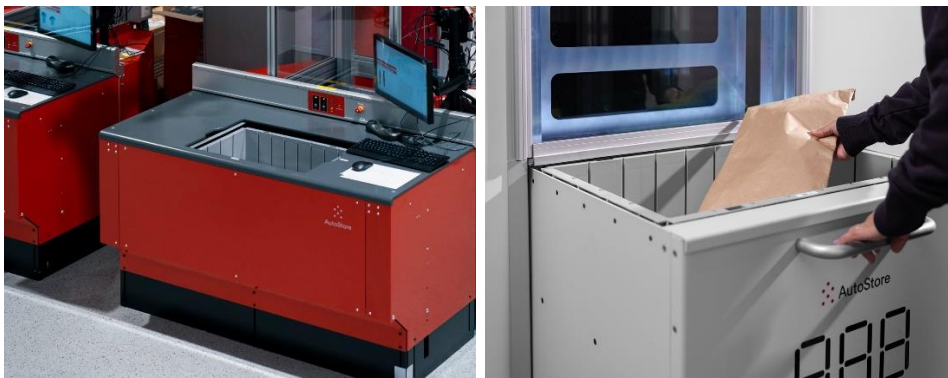

Figure 7 - Carousel and Pick-up ports (AutoStore, 2023)

2.4 CMM – Coordinate Measuring Machine

Coordinate Measuring Machines – CMM's is equipment used in quality assurance to measure the geometry of products automatically. This can be done with different technologies and requirements for manpower. In general, CMM's uses a probe system or camera to detect points on surfaces. The points can then be extracted as measurements with metrology software. CMM's are used to test if products meet the requirements of the original design. The products can be parts or assemblies, and their size and complexity are generally not restricted. CMM equipment can also be used to check deviations on the products, e.g. after wear and tear or testing.

CMM machines are normally used instead for manually equipment such as callipers and gauges. There are a wide range of different technologies and setups of CMM machines, allowing most products to be scanned. The main categories of CMM are bridge, gantry, cantilever, horizontal arm, portable measuring arm, and optical (Creaform, 2021). At AutoStore, a portable measuring arm is installed.

2.4.1 Portable Measuring Arm

Portable measuring arms are built as articulated arms with six or seven axis which need to be handled manually. The arm can be installed where needed, allowing the arm to travel to the product instead of bringing the product to the measuring arm. This is an advantage for products that are too big or complicated to bring to other areas, or to measure and analyse products while they are assembled. However, bringing the arm where needed challenges the accuracy of the system compared to other CMM equipment, though the accuracy are far better than manual measurements with callipers. The best accuracy for portable arms will be to fix them to a rigid system, to improve its accuracy and repeatability. The portable arms can have different equipment installed, i.e. different probes and laser scanning options. This allows the arm to be customized to fit the type of measurements needed.

2.4.2 Setup at AutoStore Test Lab

The CMM equipment in AutoStore's test lab consists of a non-contact arm with a laser scanner from Hexagon fixed on a granite table. The equipment from Hexagon categorize as a portable measuring arm, where the laser scanner is extra equipment. At AutoStore's test lab in Nedre Vats, the arm from Hexagon is a "Hexagon Romer Absolute Arm 85 series" with 7 axis and a reach of 3.48 m. It's accuracy is theoretically ± 0.057 mm. In addition, the laser scanner is an "Hexagon AS1 kit" with an accuracy within 43 microns and speed of 300 Hz. The system can scan up to 1.2 million points within one scan pass (Hexagon, 2023, p. 34). The measuring arm is attached to the granite table with a 3/8" thread lock. The granite table is heavy and is therefore stable and rigid. The setup can be seen in Figure 8.

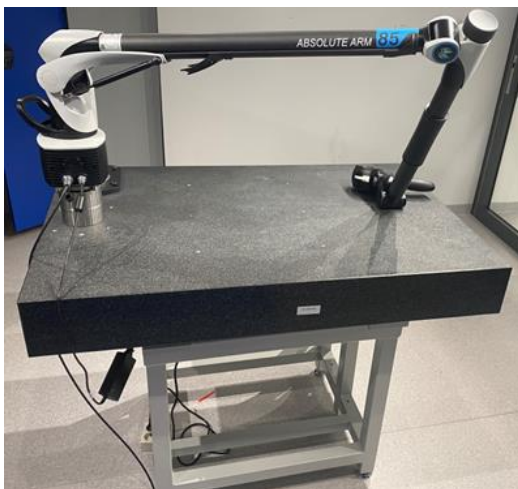

Figure 8 - CMM setup at AutoStore's test lab

2.5 Jig

A jig is a tool which is custom-made to fit a specific product in order to control the products limits, function or as a fixture tool. There are several categories of jig types, but they all have the same purpose; to solve a task. Jigs should secure repeatability and accuracy during the manufacturing process.

2.6 Standards and Guidelines

Below is a list of the applicable standards and guidelines:

- ISO standard – geometrical tolerances
 - NS-EN ISO 1101:2017 (Describes claims for how to place GPS measurements on drawings)
 - NS-EN-ISO 2692:2014 (Describes claims for maximum/minimum material requirement for GPS measurements)
 - NS-EN ISO 5458:2018 (Describes claims for GPS patterns)
 - NS-EN ISO 5459:2011 (Describes datums and references for GPS measurements)
- DIN standard – 16742:2013-10 (Tolerances for plastic moulded parts)
- AutoStore Bin Drawings – 220, 330 & 425 (Technical drawings with measurements to be checked with CMM)
- ANO-BIN-102_Measurement Specification_Guideline (AutoStore guideline for positions, calliper sizes, naming rules and tolerances, available for Bin manufacturers only)
- AS-55191_Installation Manual – Bin (Technical specifications of Bins)

2.7 Measurements and Tolerances

For all Bins, the measurements and tolerances remain the same. However, the coordinates for the measurements is according to the ISO standards and may differ between the design and sizes of the Bins. All measurements are specified on the corresponding drawings, with *ANO-BIN-102* as an additional guideline of how the measurements are extracted (positions, calliper sizes and naming rules). In total there are 33 measurement groups (included weight) with 143 measurements. All measurements related to the Bin drawings are production tolerances and are done without load in the Bins (U. Grünbeck, personal communication, December 2022).

2.7.1 Indexing

In order to identify the different measurements on the Bins, an indexing system has been created. The corners are identified with labels and the short- and long-sides are identified with numbers, see Figure 9. The indexing/orientation marks are established in the Bin moulds itself, which makes sure that the correct index is always used. All measurements are described with indexing. E.g. the outside height is known as H1-group and includes six measurements around the Bins, see Figure 10. (ANO-BIN-102, 2021, p. 4).

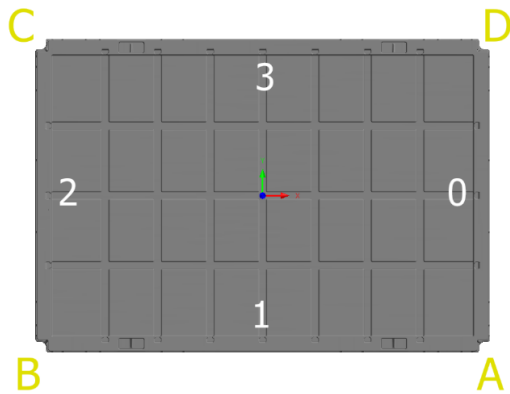

Figure 9 - Index overview (ANO-BIN-102, 2021, p.5)

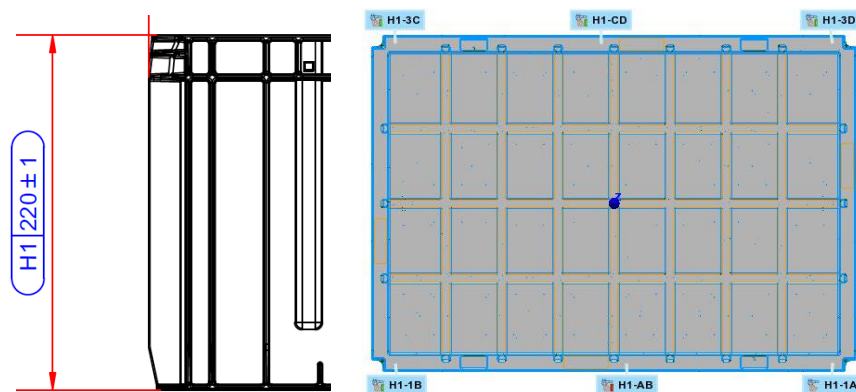

Figure 10 - Example H1 (ANO-BIN-102, 2021, p. 10)

2.7.2 Surface Measurements

Most measurements are distances and radius', some with pattern claims. These can be found using a probe. However, there are some measurements which require surface scans as the measurement is extracted from deviation in the surface. These measurements are best extracted with a laser scanner. Surface scans gives an overview of the surface deformation and can be extracted as colour maps. A surface scan of the inside bottom, measurement “F”, is shown in Figure 11.

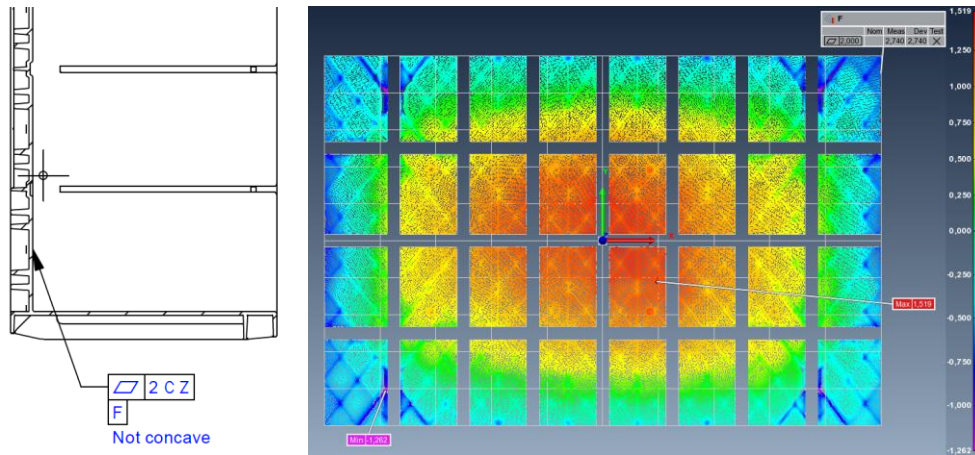

Figure 11 - Example Flatness (ANO-BIN-102, 2021, p. 9)

2.7.3 Tolerances

The tolerances are based on the geometrical tolerance group TG6 from the standard DIN 16742:2013-10. The different tolerance groups range from 1-9, where 1 is the most strict group. The tolerances can be seen in Figure 12. TG6 is chosen based on the determination rules from the standard. The tolerances specified in the drawings are production tolerances. These differ from the tolerances of the AutoStore system.

Table 2 — Plastic moulded part tolerances as symmetrical limit dimensions for sizes

Dimensions in millimetres

Tolerance group	Limit dimensions (GA) for nominal size ranges																
	1 to 3	> 3 to 6	> 6 to 10	> 10 to 18	> 18 to 30	> 30 to 50	> 50 to 80	> 80 to 120	> 120 to 180	> 180 to 250	> 250 to 315	> 315 to 400	> 400 to 500	> 500 to 630	> 630 to 800	> 800 to 1000	
TG1	W	± 0,007	± 0,012	± 0,018	± 0,022	± 0,026	± 0,031	± 0,037	± 0,044	–	–	–	–	–	–	–	
	NW	± 0,012	± 0,018	± 0,022	± 0,026	± 0,031	± 0,037	± 0,044	± 0,050	–	–	–	–	–	–	–	
TG2	W	± 0,013	± 0,020	± 0,029	± 0,035	± 0,042	± 0,050	± 0,060	± 0,090	± 0,13	± 0,15	± 0,16	± 0,18	± 0,20	–	–	
	NW	± 0,020	± 0,029	± 0,035	± 0,042	± 0,050	± 0,060	± 0,090	± 0,13	± 0,15	± 0,16	± 0,18	± 0,20	± 0,22	–	–	
TG3	W	± 0,020	± 0,031	± 0,05	± 0,06	± 0,07	± 0,08	± 0,10	± 0,15	± 0,20	± 0,23	± 0,26	± 0,29	± 0,40	± 0,55	± 0,63	± 0,70
	NW	± 0,031	± 0,050	± 0,06	± 0,07	± 0,08	± 0,10	± 0,15	± 0,20	± 0,23	± 0,26	± 0,29	± 0,40	± 0,55	± 0,63	± 0,70	± 0,77
TG4	W	± 0,03	± 0,05	± 0,08	± 0,09	± 0,11	± 0,13	± 0,15	± 0,23	± 0,32	± 0,35	± 0,41	± 0,45	± 0,63	± 0,88	± 1,00	± 1,15
	NW	± 0,05	± 0,08	± 0,09	± 0,11	± 0,13	± 0,15	± 0,23	± 0,32	± 0,35	± 0,41	± 0,45	± 0,63	± 0,88	± 1,00	± 1,15	± 1,30
TG5	W	± 0,05	± 0,08	± 0,11	± 0,14	± 0,17	± 0,20	± 0,23	± 0,36	± 0,50	± 0,58	± 0,65	± 0,70	± 1,00	± 1,40	± 1,60	± 1,80
	NW	± 0,08	± 0,11	± 0,14	± 0,17	± 0,20	± 0,23	± 0,36	± 0,50	± 0,58	± 0,65	± 0,70	± 1,00	± 1,40	± 1,60	± 1,80	± 2,10
TG6	W	± 0,07	± 0,12	± 0,18	± 0,22	± 0,26	± 0,31	± 0,37	± 0,57	± 0,80	± 0,93	± 1,05	± 1,15	± 1,60	± 2,20	± 2,50	± 2,80
	NW	± 0,12	± 0,18	± 0,22	± 0,26	± 0,31	± 0,37	± 0,57	± 0,80	± 0,93	± 1,05	± 1,15	± 1,60	± 2,20	± 2,50	± 2,80	± 3,10
TG7	W	± 0,13	± 0,20	± 0,29	± 0,35	± 0,42	± 0,50	± 0,60	± 0,90	± 1,25	± 1,45	± 1,60	± 1,80	± 2,60	± 3,50	± 4,00	± 4,50
	NW	± 0,20	± 0,29	± 0,35	± 0,42	± 0,50	± 0,60	± 0,90	± 1,25	± 1,45	± 1,60	± 1,80	± 2,60	± 3,50	± 4,00	± 4,50	± 5,00
TG8	W	± 0,20	± 0,31	± 0,45	± 0,55	± 0,65	± 0,80	± 0,95	± 1,40	± 2,00	± 2,30	± 2,60	± 2,85	± 4,00	± 5,50	± 6,25	± 7,00
	NW	± 0,31	± 0,45	± 0,55	± 0,65	± 0,80	± 0,95	± 1,40	± 2,00	± 2,30	± 2,60	± 2,85	± 4,00	± 5,50	± 6,25	± 7,00	± 7,75
TG9		± 0,30	± 0,49	± 0,75	± 0,90	± 1,05	± 1,25	± 1,50	± 2,25	± 3,15	± 3,60	± 4,05	± 4,45	± 6,20	± 8,50	± 10,00	± 11,50

NOTE 1 W: Tool-specific dimensions; NW: Non-tool-specific dimensions.
NOTE 2 The differentiation of tool-specific and non-tool-specific dimension is not necessary for TG9.
NOTE 3 Tolerance mean dimensions apply as nominal sizes for moulded part drawings ($N_T = C_T$). For tolerancing of the distance between parallel surfaces that do not face each other directly but are arranged shifted to one another, the D_T dimension according to 7.2 of this standard is to be used as nominal size.
NOTE 4 Dimensions under 1 mm and above 1 000 mm are subject to mandatory agreement.
NOTE 5 Only the limit values for non-tool-specific dimensions are to be used for general tolerances.
NOTE 6 Tolerances for material thicknesses are subject to mandatory agreement.
NOTE 7 General tolerances are to be indicated in the design documentation as follows. Example: DIN 16742 – TG6.
NOTE 8 For validation of machine and process capability, see Annex E.

Figure 12 - Tolerances (Deutsches Institut für Normung, 2013, p. 51)

2.7.4 Measurements

All measurements has been plotted on the 3D CAD model of the 425 Bin to show where the different measurements are taken. Colours are used to categorize the measurements, see the bullet list below:

- Green = surfaces,
- Red = heights,
- Yellow = lengths,
- Purple = radius',
- Turquoise = thickness',
- White = widths.

The measurements on the Bin can be seen in Figure 13 through Figure 16 below. The total distance of the cylindrical bars is shown for easier understanding of which measurement category the measurement represent. The scan program will only extract data from the calliper endpoints. Otherwise, the guideline *ANO-BIN-102* is followed.

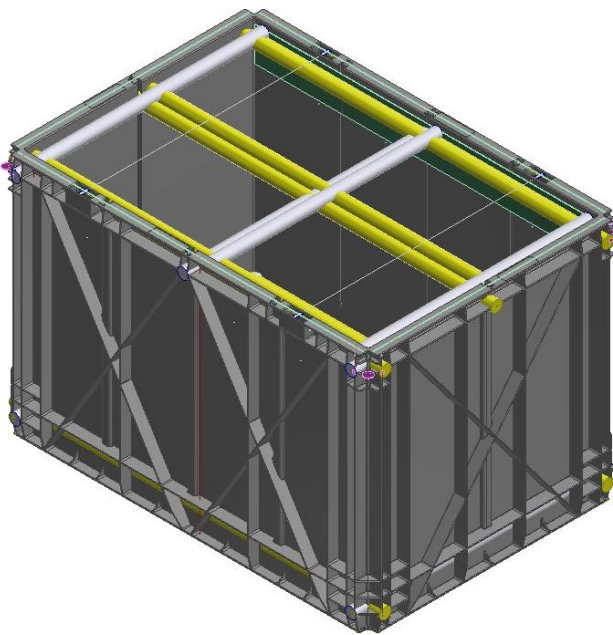

Figure 13 - Measurements seen on 425 Bin, 3D view

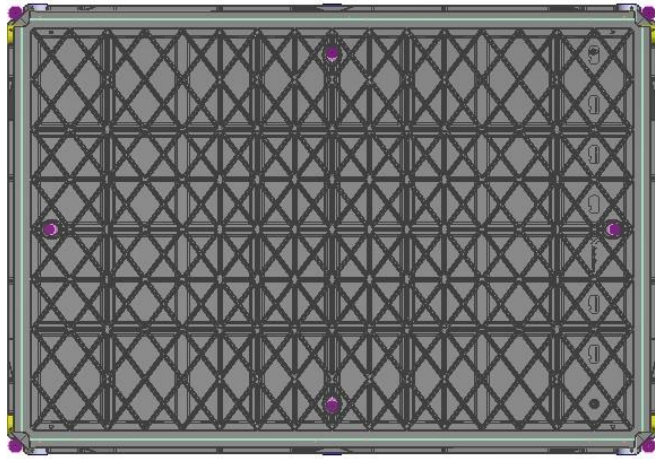

Figure 14 - Measurements seen on 425 Bin, bottom view

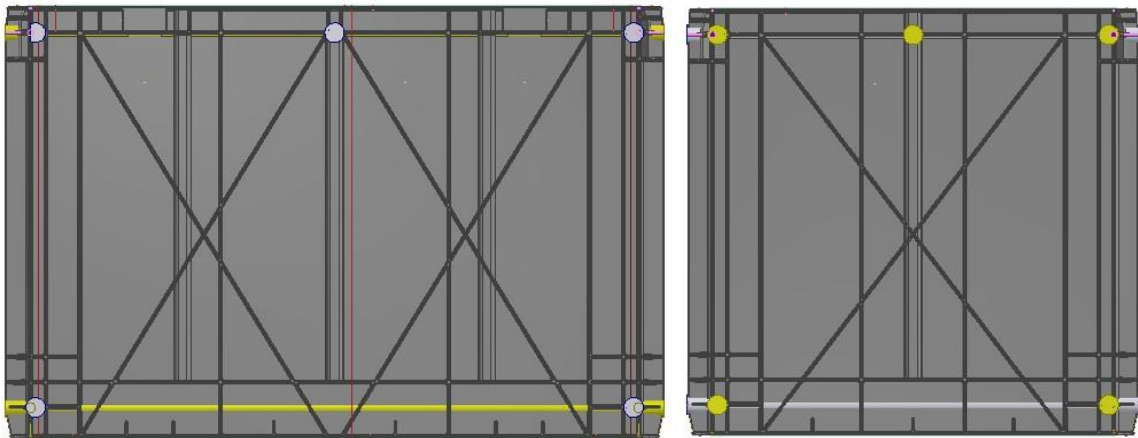

Figure 15 - Measurements seen on 425 Bin, front and right-views

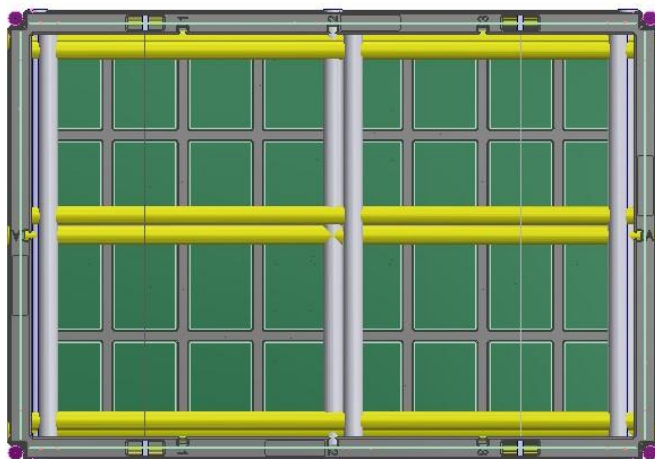

Figure 16 - Measurements seen on 425 Bin, top view

3 Method

There are various methods for engineering design. Among others, there are descriptive models, creative methods, and rational methods. Descriptive methods identifies the importance of generating a concept at an early stage. The creative methods are a type of tools which can be used in certain steps of the design process, as they are not regarded as design methods. Rational methods are a mix between descriptive and creative methods, as they try to search for a solution to the problem while including various activities and details to make sure that important aspects are not forgotten in the design process (Mauseth, 2022, p. 36).

In this project, rational methods are used, whereas this chapter will focus on the design process itself. To find solutions to the problem, the following steps will be followed:

1. Identifying opportunities (see previous chapters 1.2, 1.3, 1.4 & 2.2)
2. Clarification of Objectives
3. Setting requirements
4. Determining characteristics
5. Generating alternatives
6. Evaluation of alternatives
7. Detailed solution

(Mauseth, 2022, p. 46)

3.1 Clarification of Objectives

The objectives and sub-objectives of the problem is defined as a flowchart in Figure 17. The objectives are based on the list of limitations given in Chapter 1.3. The flowchart is structured with the “objective tree method” with higher and lower rank items. If a pattern is followed from the top, the items below will have the characterises as “how” the problem will be solved. Reading the diagram bottom-up tells “why” the objective is a solution. (Mauseth, 2022, pp. 47-48)

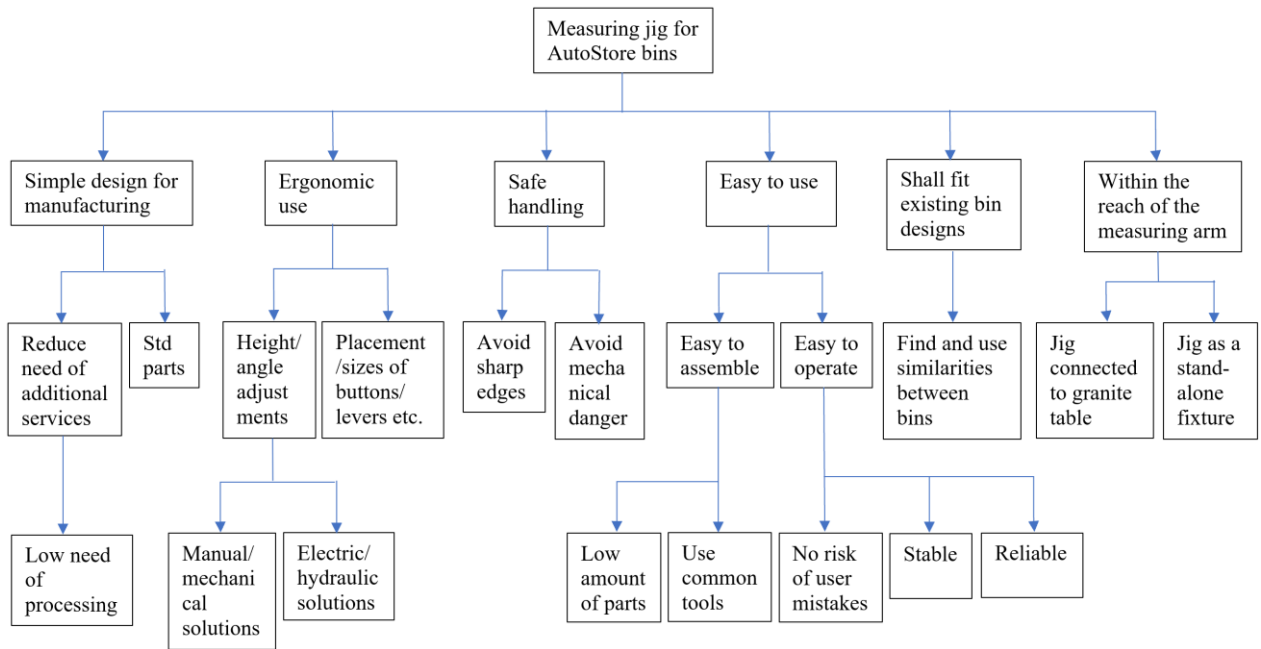

Figure 17 - Objective tree for the measuring jig

3.2 Specifications and Requirements

3.2.1 Specifications for Measuring Jig

Table 2 – Specifications and requirements for the measuring jig

Condition	Specification	Comments
Bin weight (load)	3.3 – 6.0 kg	Bin weight range between the different sizes and materials.
Point load on Bin during measurements	App. 5.0 kg	Probing on Bins. The jig shall keep the Bin stable in X-, Y- and Z-directions.
Boundary conditions	Fixed at minimum one side, up to several fixation points.	Valid for both Bin and jig.
Physical conditions of jig	Maximum size can be slightly larger than footprint of the Bins (649x449 mm).	

	Shall fit existing Bin designs without affecting tolerances or the shape of the Bins.	
Requirement for stiffness of the jig	No bending or rotation allowed. Stable/rigid design.	
Design room	Within the reach of the arm to the Bins. In connection to the granite table.	See Chapter 3.2.2
Weight of jig	Below 15 kg	To be handled manually
Temperatures	Ambient (20-23°C)	Degree Celsius
Assembly	If several parts and materials: All parts shall be within given claims and properties. Easy to assemble/disassemble.	
Production claims	Easy to produce with known production processes and high accuracy.	
Operational claims	Ergonomic use, standing height. Easy to operate	Shall be possible for all operators to scan in an ergonomic way.
Expected lifetime	5+ years	
Service claims	Yearly service, weekly control.	Weekly control: Straightness checks, adjustments etc.
QC claims	Jig to be within 0.1 mm deviation from nominal in X-, Y-, and Z-directions	Will be specified on drawing.
Expected usage between services	220 days – Approximately 550 Bins/scans.	Will be in use on a daily basis in general.
Sustainability	Use known parts where possible (reduce amount of specially designed parts)	Recycle/reuse.

Safety	Avoid sharp edges, possibilities for the jig falling/hitting or other possibilities for injuring operators.	Handling safety
--------	---	-----------------

3.2.2 Available Work Space Area

The development of the jig is dependent on the available work space area. The measuring jig need to be designed to work with the current equipment (limits in space), the operators (ergonomics) and the different Bin heights. The available design space is dependent on the reach of the measuring arm, with origin in centre of the arm base. The design space will then have the following dimensions: $\emptyset \times H = 3500 \times 1300$ [mm], see Figure 18, Figure 19 and Figure 20.

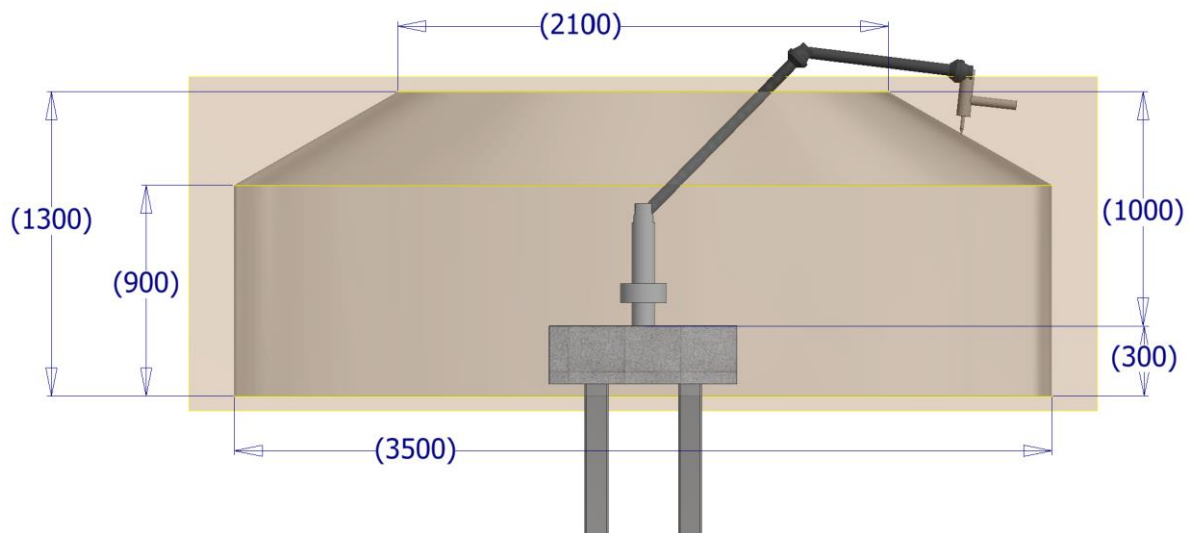

Figure 18 - Arm reach, seen from right. A total height reach of 1300mm, where the 900mm reach represents the height reach when the arm is extracted maximum in length/width. 1000mm and 300mm represents the arm reach in height from the base on the table.

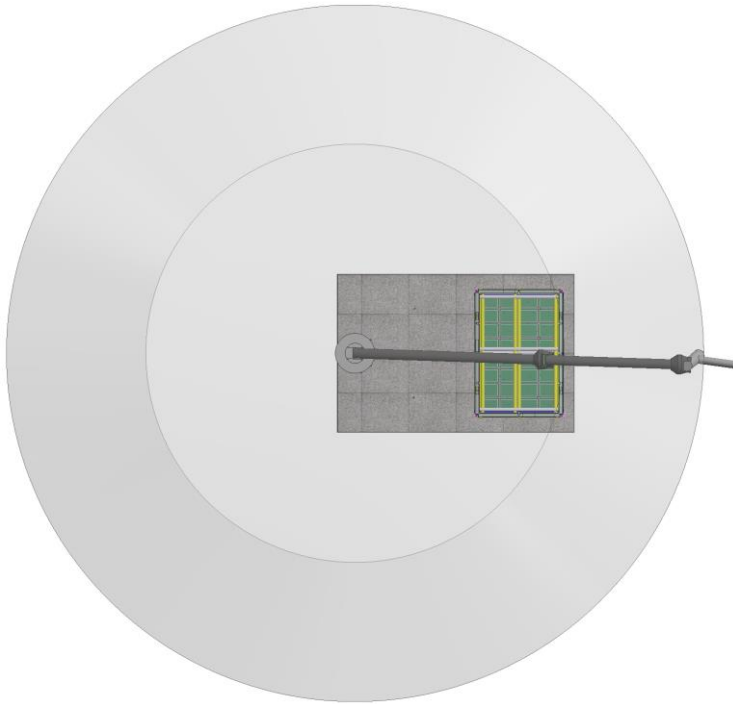

Figure 19 - Arm reach, seen from top – with the Bin from Figure 13 for scale.

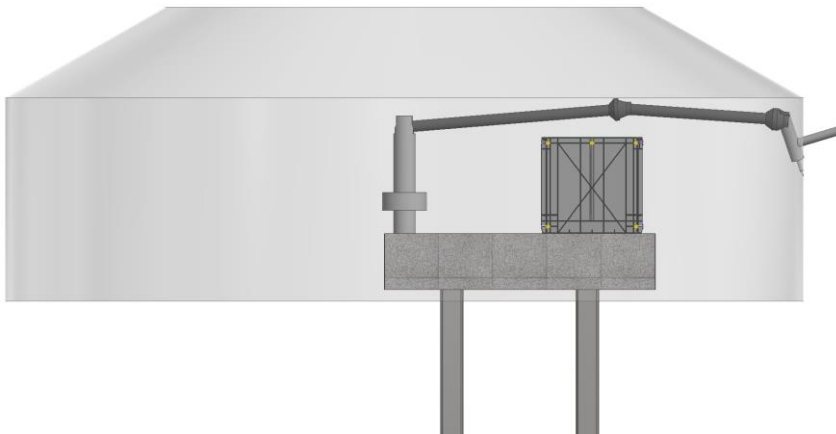

Figure 20 - Arm reach, seen from front – with the Bin from Figure 13 for scale.

3.3 Determining Characteristics

Determining characteristics can help communication and understanding of the product development. Wishes from customers are not always possible to fulfil due to different engineering characteristics. The customers wishes should be in focus, and a “House of Quality” (HoQ) matrix will help address the customer attributes while it shows their relation to the engineering attributes (Mauseth, 2022, pp. 54-55). See how the matrix is built up with descriptions in Figure 21. The matrix for this project can be seen in Figure 22.

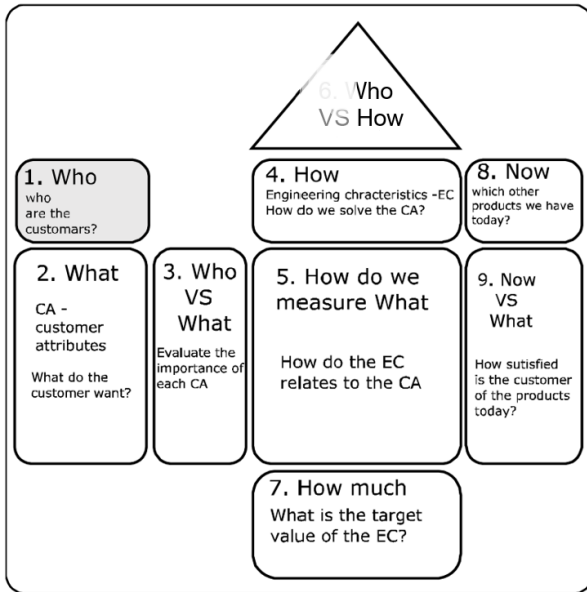

Figure 21 - Description of "House of Quality" matrix (Mauseth, 2022, p. 63)

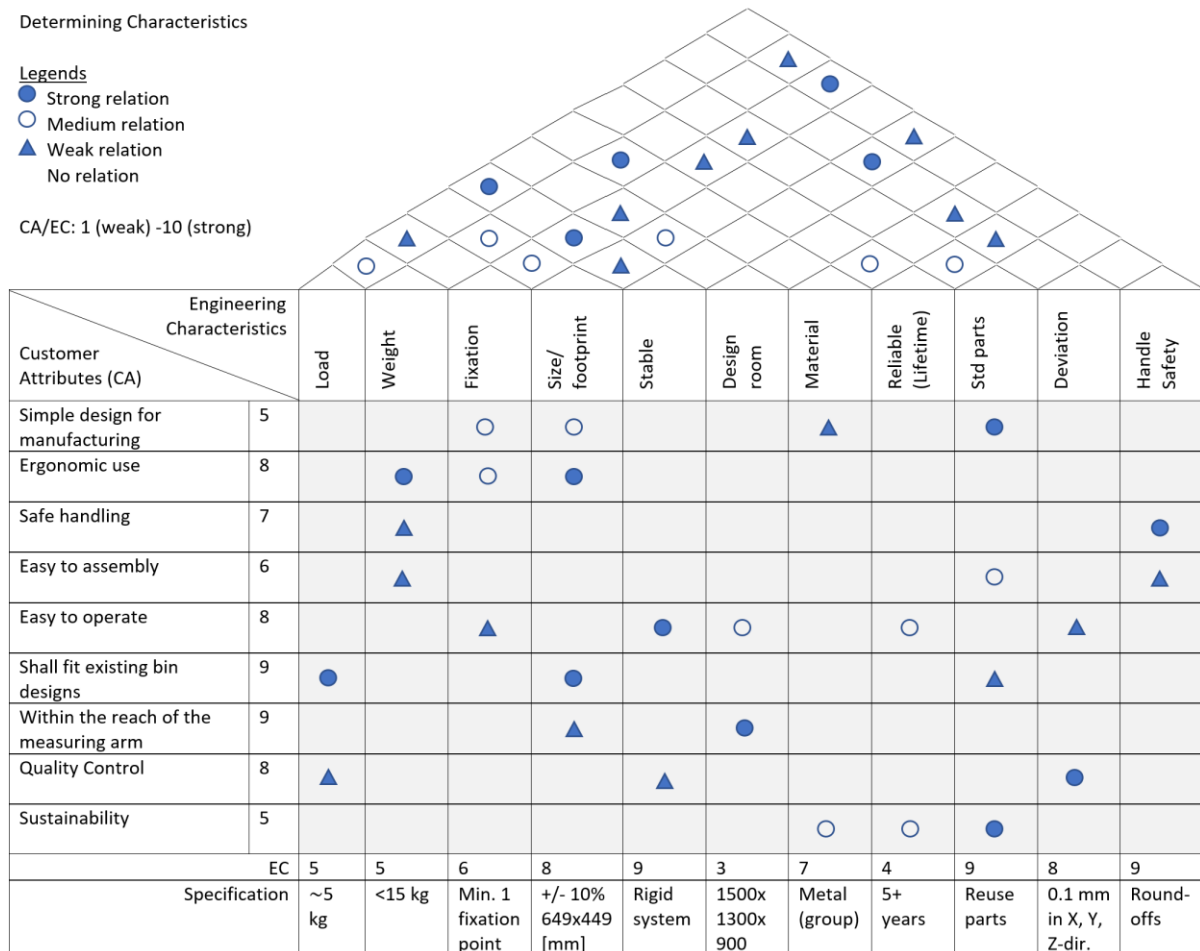

Figure 22 - Determining characteristics - HoQ matrix. Items 8 & 9 from Figure 21 is not applicable.

3.4 Generating Alternatives

Generating alternatives is a part of the product design process. A method which can be used is the “Morphological Chart Method”. The aim for this method is to find the best possible solution for a complex problem with many design parameters, constraints and limitations. This is done by generating different solutions for the product, and thereby extend the search for new solutions. The solutions should be presented in a chart (Mauseth, 2022, pp. 64-65).

A set of categories have been created to simplify the search for alternatives. The measuring jig will consist of several parts which will be interacting with each other. The different categories represents parts or the operation of the system. The categories is described on the bullet list below and shown in colours on Figure 23. In each category, several alternatives have been generated, see subchapters 3.4.1- 3.4.5 below. All alternatives are generated based on given objectives and specifications.

- A: Height adjustment (blue)
- B: Bin fitment plate (red)
- C: Placement/fixation of jig (green)
- D: Assembly system (yellow)
- E: Operation (pink)

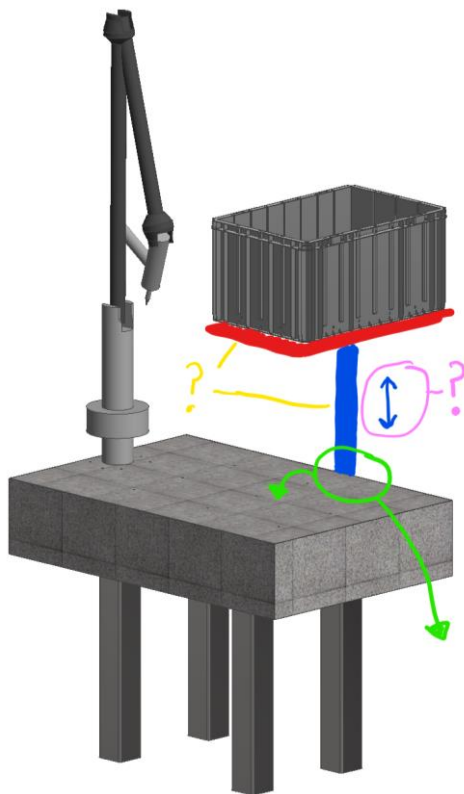
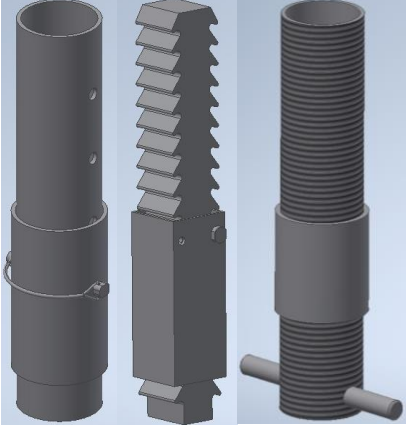
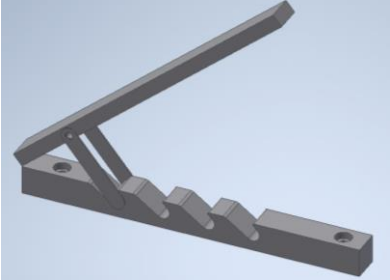
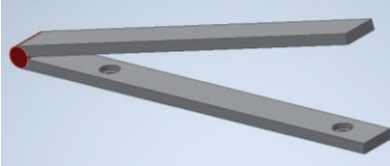



Figure 23 - Generating alternatives, parts and categories

3.4.1 Category A – Height Adjustments

Table 3 - Alternatives, height adjustments

Item	Name	Figure	Description
A.1	Pipe-in-pipe	 <p data-bbox="456 801 863 860"><i>Figure 24 – Pipe-in-pipe with lock pin, zig-zag lock and threads</i></p>	<p data-bbox="898 360 1390 891">A pipe-in-pipe method allows only one adjustment point, and therefore needs to be placed in centre of the Bin. There are various possibilities to adjust and lock the pipes, in Figure 24 shown by a lock pin, a zig-zag lock and with threads. The lock pin has few components, the zig-zag is sturdy, and the threaded option needs an extra spinning plate.</p>
A.2	Angle adjusting profile	 <p data-bbox="456 1211 820 1270"><i>Figure 25 - Angle adjustment with support leg</i></p>  <p data-bbox="456 1458 820 1516"><i>Figure 26 - Angle adjustment with rotating lock</i></p>	<p data-bbox="898 911 1390 1384">The angle adjustment allows the Bins to tilt into a better ergonomic position for the operators. When the Bin is tilted, it is possible to scan around all sides of the Bin without adjusting the height. Two solutions are presented: A support leg with four angle steps, see Figure 25, and a rotating lock hinge, see Figure 26.</p>
A.3	Linear guideway	 <p data-bbox="456 1787 874 1845"><i>Figure 27 - Linear guideway with a ball runner block (Bosch Rexroth, 2023)</i></p>	<p data-bbox="898 1516 1378 1771">Linear guideways allows a smooth, reliable and sturdy adjustment of the height, as well as different options for locks and operation, see an example in Figure 27.</p>

A.4	Integrated in category C		Depending on the placement of the measuring jig, integrated height adjustments can be a possibility. This might reduce the need of specially designed parts.
-----	--------------------------	--	--

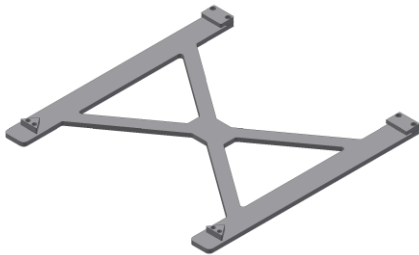
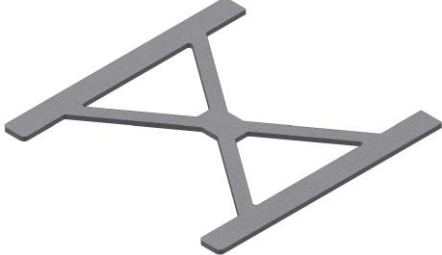
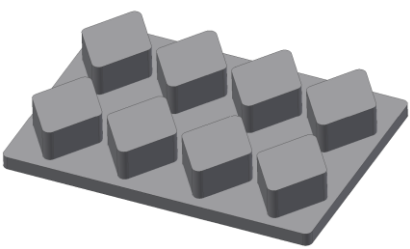

3.4.2 Category B – Bin Fitment Plate

Table 4 - Alternatives, Bin fitment plate

Item	Name	Figure	Description
B.1	Profile with locks	 <p><i>Figure 28 – Bin fitment plate with locks</i></p>	The profile with locks are based upon placing the bottom rim of the Bin into the locks. This ensures that the Bin stays in place in all directions, see an example design in Figure 28.
B.2	Profile without locks	 <p><i>Figure 29 – Bin fitment plate with surface treatment</i></p>	The profile without locks are based on surface treatment of the profile, or that the bin will be attached with other methods (e.g. glue). The Bin can also be placed as is, see an example design in Figure 29.
B.3	Structured fitment	 <p><i>Figure 30 – Bin fitment plate with structured fitment</i></p>	The structured fitment is based on using the bottom structure of the Bin to keep the Bin in place. A smaller surface in the bottom centre might be possible to use, see an example design in Figure 30.
B.4	Combination		A combination of the above mentioned items may increase the fitment of the plate on the Bin.

3.4.3 Category C – Placement of Measuring Jig

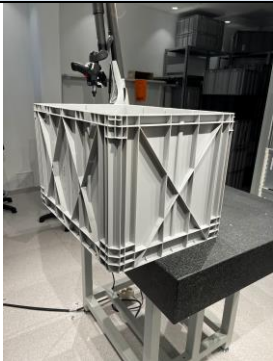
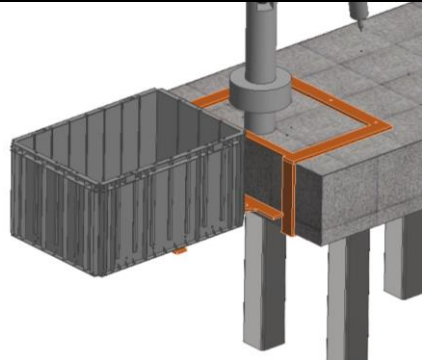
Table 5 - Alternatives, placement of measuring jig

Item	Name	Figure	Description
C.1	On granite tabletop	 <p>Figure 31 - Placement on granite tabletop</p>	The simplest solution is to attach the measuring jig on top of the granite table, using the pre-drilled inserts. The table is tall, so a solution with this placement may challenge the ergonomic constraint, see Figure 31.
C.2	Attached to granite table	 <p>Figure 32 - Jig attached to granite table</p>	The reach of the measuring arm make it possible to attach additional profiles (to the granite table) on the backside of the granite table to better adjust the height, see Figure 32. It will also be easier to scan underneath the Bin, as the table surface is off the way for the laser scanner.
C.3	Free-standing, tripod	 <p>Figure 33 - Hexagon MST36 Portable Precision Tripod (Hexagon, 2022, p.43)</p>	For the measuring arm, Hexagon has developed collapsible, height adjusting tripods to fit with their measuring arms, see Figure 33. However, they can fit other equipment as well due to the threaded insert (Hexagon, 2022, p. 43).
C.4	Free-standing, tailormade		A tailormade free-standing option. Can be made with existing Rexroth parts and/or custom designed parts.

C.5	New table with combined features	 <p data-bbox="459 436 794 488"><i>Figure 34 - U-shaped table (AJ Produkter, 2023)</i></p>	<p data-bbox="922 197 1385 286">The U-shaped table in Figure 34 is originally designed for pallets.</p> <p data-bbox="922 309 1393 616">However, the U-shaped table gives space to easily operate underneath other products as well. It is possible to attach both the measuring arm and the measuring jig on the U-table.</p>
-----	----------------------------------	---	--





3.4.4 Category D – Assembly System

Table 6 - Alternatives, assembly system

Item	Name	Figure	Description
D.1	Bosch Rexroth	 <p data-bbox="459 1249 730 1301"><i>Figure 35 - Rexroth parts (Bosch Rexroth, 2023)</i></p>	<p data-bbox="805 891 1385 1370">The AutoStore system, and especially the grid structure is built with standardized Rexroth parts. An alternative is therefore to use the different Rexroth parts to build the measuring jig, see Figure 35. Rexroth has different equipment which can be used together with the standardized profiles; e.g. linear guides, angle brackets etc. which may ease the assemble and operation of the jig.</p>
D.2	Specially designed parts		<p data-bbox="805 1388 1358 1473">All parts to be designed and manufactured specifically for the measuring jig.</p>
D.3	Standard items		<p data-bbox="805 1556 1342 1697">Use and combine standard parts which is easily accessible. May be difficult to find standard parts which fit the Bins easily.</p>
D.4	Combination		<p data-bbox="805 1724 1390 1921">Rexroth profiles and other shelf items can be used as a height adjusting alternative. Thereafter, a specially designed Bin fitment plate can be attached.</p>

3.4.5 Category E – Operation of Jig

Table 7 - Alternatives, operation of jig

Item	Name	Figure	Description
E.1	Mechanical	 <p><i>Figure 36 – Clamping lever (Bosch Rexroth, 2023)</i></p>	Mechanical solutions are often handled manually, see example in Figure 36. Therefore, parts should be designed for easy and precise handling.
E.2	Electric	 <p><i>Figure 37 – Electric linear guideway (THK, 2023)</i></p>	Electric solutions are reliable and precise. They can easily be adjusted to fit different needs, both in speed, scalability and forces. Immediate feedback for diagnostics and maintenance is available, see example in Figure 37.
E.3	Hydraulic	 <p><i>Figure 38 - Hydraulic jack (Maxtech, 2022)</i></p>	Hydraulic solutions, as in Figure 38, are easy to install as there are no additional components to make the solution work. Hydraulic solutions are reliable, but may not be as precise as electrical systems.
E.4	Combination	 <p><i>Figure 39 - Electro-mechanical lifting cylinder (Bosch Rexroth, 2023)</i></p>	A combination of different type of equipment is possible. In Figure 39 shown by a electro-mechanical lifting cylinder.

3.4.6 Morphological Chart

To get a better overview of the categories and alternatives, a morphological chart is shown in Table 8 below.

Table 8 - Morphological chart – solutions

Category	Alternative Parameter	Alternative				
		1	2	3	4	5
A	Height adjustment	Pipe-in-pipe w/different lock options	Angle adjusting profile	Linear guideways	Integrated in category C	
B	Bin fitment plate	Profile (size of Bins) with locks	Profile (size of Bins), no locks	Structured fitment	Combination	
C	Placement of jig/fixation	On granite tabletop	Attached to granite table	Free-standing, tripod	Free-standing, tailormade	New table
D	Assembly system	Bosch Rexroth*	Specially designed parts	Standard items	Combination	
E	Operation	Mechanical	Electrical	Hydraulic	Combination	

*Used as standard mounting system by AutoStore, combined with specially designed parts.

3.5 Evaluating Alternatives

There are several ways and methods to evaluate the alternatives. A systematic approach is preferred to be able to document choices upon customers based on the information given. In this project, the systematic approach “ranking by relative weight” was chosen (Mauseth, 2022, p. 83). The process of evaluating the alternatives is explained below.

1. **Rank objectives:** Ranking the objectives by a calculated weighted factor based on score numbers 1-10 (Equation 1). The differentiation between the score numbers are; 1-3: Acceptable, 4-6: Fair, 7-9: Good, 10: Optimal. The results are presented in Table 9.
2. **Generate solution concepts:** Construct concepts based on generated alternatives. In this project four concepts were constructed in Table 10 and explained in Table 11. Concepts are based on alternatives from categories A-C.

3. **Scoring:** The solution concepts will be given scores towards the objectives. The weighted sum is to be calculated (Equation 2), whereas the concept with the largest weighted sum is the concept to develop further. See the scoring and results in Table 12.

Weighted Factor:

$$WF = \frac{OS_i}{\sum OS} \text{ for } i = 1,2,3 \dots 6, \text{ where } OS = \text{Objective score } \langle 1, 10 \rangle \quad \text{Equation (1)}$$

Weighted Sum:

$$WS_i = \sum_{j=1}^n WF_j * CS_{ij} \text{ for } i = 1,2,3,4, \text{ where } CS = \text{Concept Score} \quad \text{Equation (2)}$$

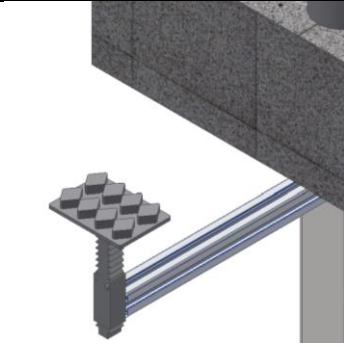
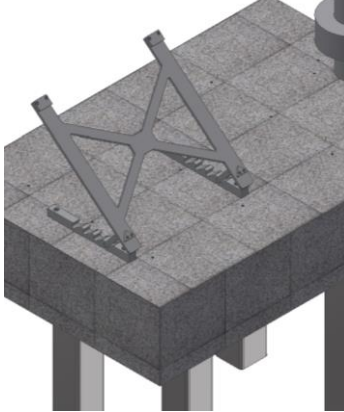

Table 9 - Objectives weight factor

Objective	Importance rank	Score	Weight Factor
Simple design for manufacturing	6	6	0.13
Ergonomic use	3	8	0.18
Safe handling	4	7	0.16
Easy to use	5	6	0.13
Shall fit existing bin designs	1	9	0.2
Within the reach of the measuring arm	2	9	0.2
SUM		45	1.0

Table 10 – Morphological chart of solution concepts

Alt. Cat.	1	2	3	4	5
A - Height adjustment	Pipe-in-pipe	Angle	Linear guideway	Integrated in category C	
B - Bin plate	Profile with locks	Flat plate	Structured	Combination	
C - Placement	On tabletop	Attached to table	Free standing, tripod	Free standing, tailormade	New table
Concept number	1	2	3	4	

Table 11 - Solution concepts

Concept	Figure	Concept vs objectives
1	 <p data-bbox="336 658 576 689">Figure 40 - Concept 1</p>	<p data-bbox="703 300 1374 394"><i>Zigzag height adjustment connected to the granite table with a small structured Bin fitment plate:</i></p> <p data-bbox="703 412 1385 667">The height adjustment and the attachment solution should provide enough space for the measuring arm, see Figure 40. The solution may require several specially designed parts to make a well functional overall solution. The solution offer ergonomic use.</p>
2	 <p data-bbox="336 1144 576 1176">Figure 41 - Concept 2</p>	<p data-bbox="703 719 1390 813"><i>Angle adjusting brackets on tabletop with a locking Bin fitment plate:</i></p> <p data-bbox="703 831 1353 1137">When using a concept with angle adjustment, it is possible to place the concept on top of the granite table while still ensuring ergonomic use by tilting the bins, see Figure 41. This helps both for ergonomic use and for the reach of the measuring arm compared to today's setup.</p>
3	 <p data-bbox="336 1637 576 1668">Figure 42 - Concept 3</p>	<p data-bbox="703 1211 1310 1305"><i>Tripod with height adjustment with a flat Bin fitment plate:</i></p> <p data-bbox="703 1323 1385 1682">To use a solution which includes both a placement and a height adjustment is a possibility, in Figure 42 shown by a tripod. The concept is easy to assemble and can be placed near the measuring arm. The operator need to pay attention to the tripod feet, and therefore, a flat Bin fitment plate can be used due to less possibilities for moving the Bin.</p>

4	 <p style="text-align: center;">Figure 43 - Concept 4</p>	<p><i>Linear guideway (or similar) on a free-standing solution with a combination Bin fitment plate:</i></p> <p>It is possible to design a solution where the focus is on the complete concept itself, not only the different parts needed. This opens up possibilities for linear guideways or similar for the height adjustment, see an example in Figure 43.</p>
---	--	--

Table 12 - Weighted solution concepts

Objective (organized by importance)	Weight Factor	Concept Scores, CS			
		1	2	3	4
Shall fit existing Bin designs	0.2	5	6	9	8
Within the reach of the measuring arm	0.2	9	9	9	8
Ergonomic use	0.18	6	7	5	8
Safe handling	0.16	6	7	6	8
Easy to use	0.13	5	7	6	7
Simple design for manufacturing	0.13	4	5	8	6
SUM		35	41	43	45
Weighted sum		6.01	6.94	7.28	7.61
Rank		4	3	2	1

3.6 Detailed Solution

In Chapter 3.5, concept number 4 – “*Linear guideway (or similar) on a free-standing solution with a combination of features for the Bin fitment plate*”, from now named “Bin measuring jig” – “BMJ”, was the winner. In this chapter, the concept will be developed further to generate a better detailed solution to the problem description. Categories D (assembly system)

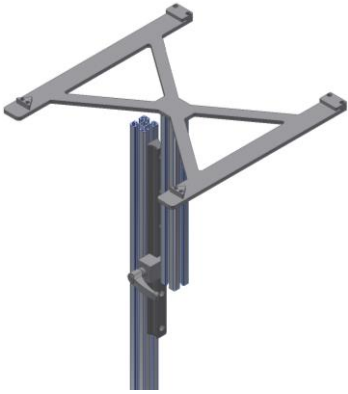
and E (operation) from Chapter 3.4 will be evaluated in this chapter. Choices from these two categories are based on characters given in Table 13 below. As before, scores are given with a 1-10 score table.

Table 13 – Characters, categories D & E

Cat. Alt.	D		E	
	Score	Explanation of given score	Score	Explanation of given score
1	9	As the Rexroth system is used by AutoStore as a standard mounting/assembly system, availability of parts and expertise of mounting and handling will not be an issue.	7	A mechanical solution is a preferred method to operate the jig due to the simpleness of the system.
2	7	Specially designed parts have the advantage of creating a better fit, especially for the Bin fitment plate.	8	Since there are power outlets nearby where the measuring jig will be placed, the advantages of an electrical system is hard to neglect.
3	5	Standard items are used mostly for screws & bolts, pipe parts, pipes, sheets and beams. For this project, many parts are hard to make use of as is.	5	Since hydraulic solutions are less precise, it is preferred to use a more precise system.
4	10	A combination of specially designed parts, Rexroth parts and standard items can make the best overall solution for the Bin measuring jig, with the best from all alternatives.	4	There are possibilities of a combination of systems, allowing for a crossover between the previous alternatives. However, these solutions may be more challenging to understand and to design parts for.

Based on the scores given in Table 13 above, two prototypes of the Bin measuring jig has been developed due to the low difference in scores. One mechanical operated and one electric version (category E), both with a combination of parts (category D), see subchapters 3.6.1 and 3.6.2. Both versions have an additional specially designed baseplate to attach the Bin fitment plate to the Rexroth parts. The baseplates are designed to fit the different versions.

3.6.1 Manual Version

The manual version is built with Rexroth profiles to make a framework, see Figure 44. The dimensions of the framework are $L \times W \times H = 450 \times 280 \times 800$ [mm], making the footprint smaller than the bins (649×449). Some pros and cons are listed in Table 14 below.

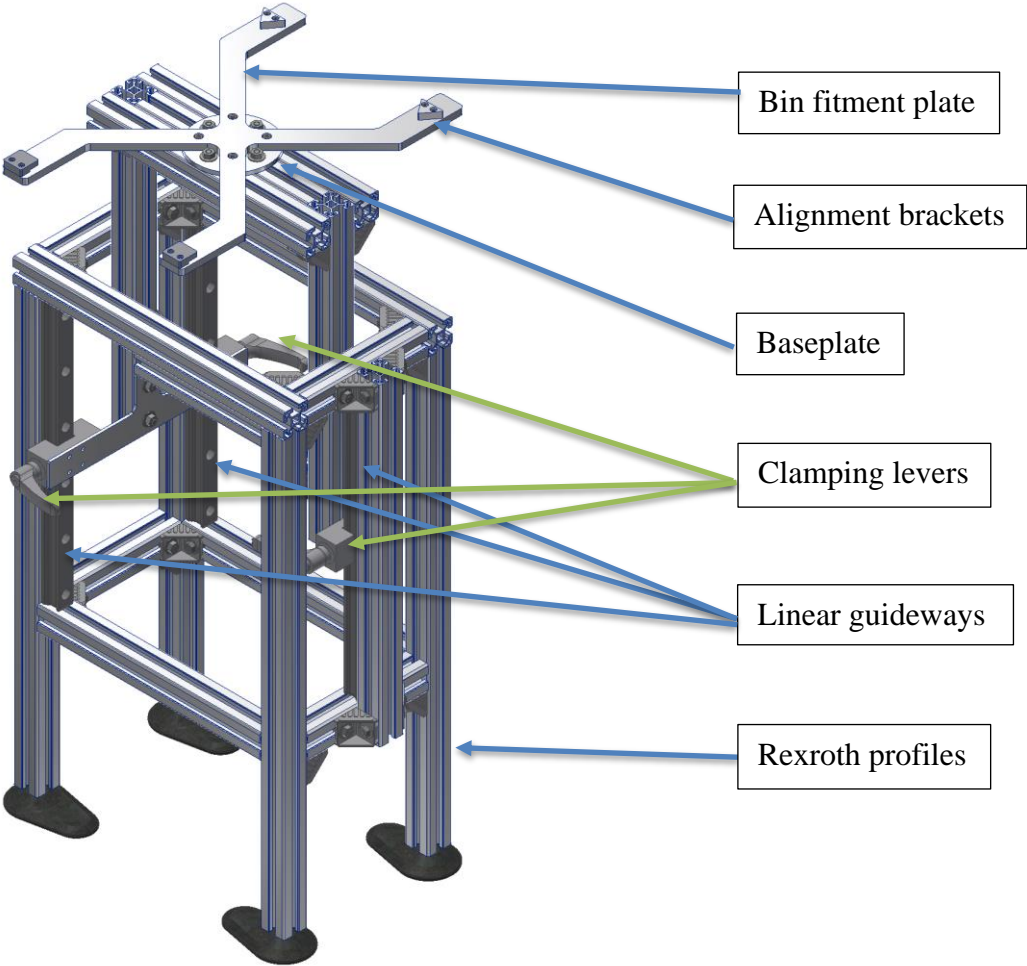

Figure 44 - Bin Measuring Jig, manual version

Table 14 - BMJ manual, pros and cons

Objectives	Pros	Cons
Simple design for manufacturing	<ul style="list-style-type: none"> - Easy to manufacture the plates, - Standard parts, - Easy setup for prototyping 	<ul style="list-style-type: none"> - A lot of profiles to cut
Ergonomic use	<ul style="list-style-type: none"> - Height adjustment of 400 mm 	<ul style="list-style-type: none"> - Non-ergonomic placement of handles - Hard to adjust height when Bins are attached
Safe handling	<ul style="list-style-type: none"> - Lockable guides 	<ul style="list-style-type: none"> - Should pay attention when adjusting the height (when all three locks are off)
Easy to use	<ul style="list-style-type: none"> - Stable 	<ul style="list-style-type: none"> - High amount of parts to assemble - Risk of user mistakes

3.6.2 Electric Version

The electric version is built with Rexroth lift modules for height adjustment, see Figure 45.

The lift modules represents the linear guide motion, only electrical. The dimensions are $L \times W \times H = 530 \times 450 \times 815$ [mm]. Pros and cons are listed in Table 15 below.

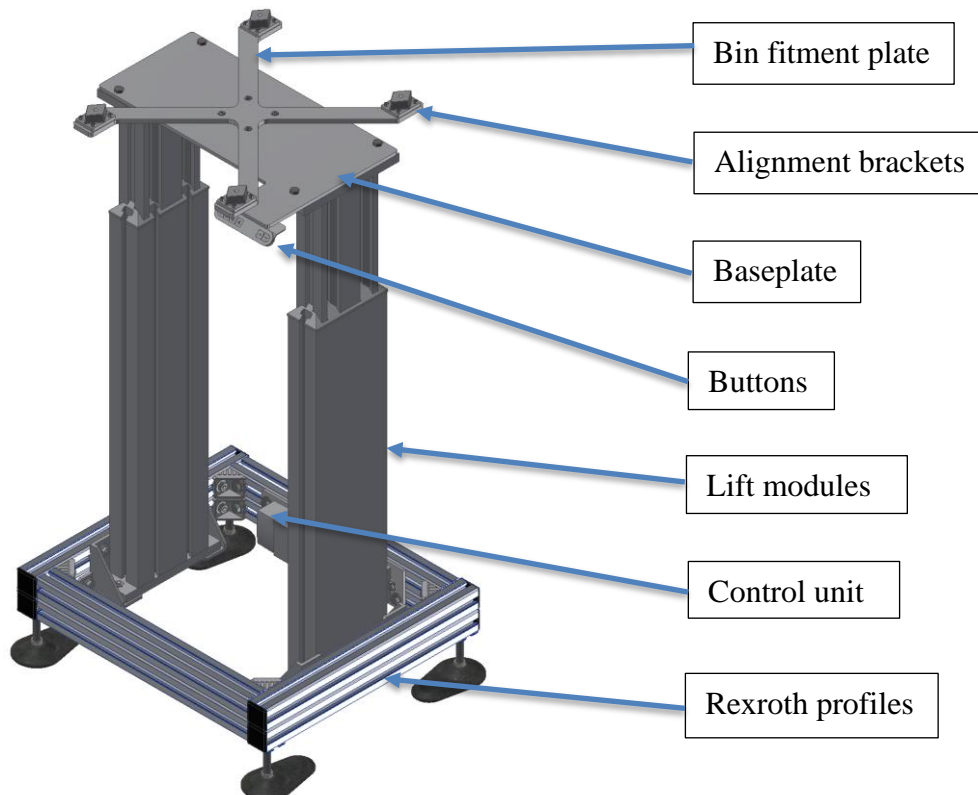

Figure 45 - Bin Measuring Jig, electric version

Table 15 - BMJ electric, pros and cons

Objectives	Pros	Cons
Simple design for manufacturing	<ul style="list-style-type: none"> - Easy to manufacture plates, - Standard parts 	<ul style="list-style-type: none"> - Harder to adjust the concept
Ergonomic use	<ul style="list-style-type: none"> - Height adjustment of 410 mm 	
Safe handling	<ul style="list-style-type: none"> - Low possibility of danger 	
Easy to use	<ul style="list-style-type: none"> - Low amount of parts to assemble - Stable and reliable, - No risk of user mistakes 	

3.6.3 Choice of Version

Based on the low amount of cons in Table 15, the electric concept will be analysed and developed further. However, the manual may be the preferred version to start with for prototyping as the parts needed are easy accessible from the storage at AutoStore. An overview drawing of the assembled version can therefore be found in Attachment E.

3.6.4 Detailing

3.6.4.1 Baseplate

The baseplate need to be a solid rectangular shape due to the function of the plate; It serves both as a plate to align the lift modules as well as a fixture plate for the Bin fitment plate. The shape is therefore not discussed any further, however, two baseplates have been developed to fit the suggested shapes. The only difference is the position of the tapped holes, see Figure 46. The area of the baseplates are $L \times W = 440 \times 280 [mm]$.

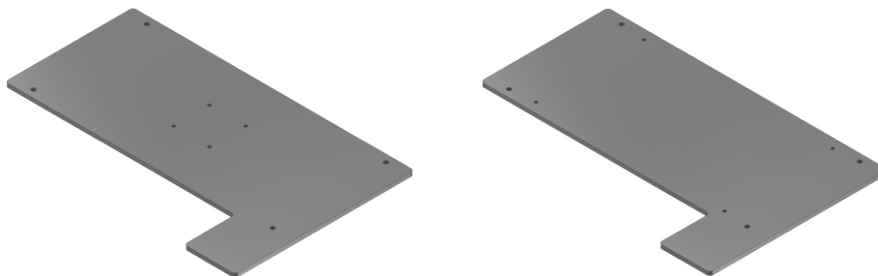

Figure 46 – Baseplates, X-shaped and H-/O-shaped

3.6.4.2 Alignment Brackets

To make sure the Bin is in place during scanning, extra brackets to attach to the Bin fitment plate have been made. The structure on the underside of the bins were used to make structures/ brackets which slides into the Bins, see Figure 47. The brackets will align with the bottom of the Bin. A possible risk may therefore be that the structure is pressing on the bottom surface – and thus the scanning results of the F-measurement (as shown in Figure 11) may be interrupted. This need to be tested/ verified with a prototype. The dimensions are $LxWxH = 60x44x19.5 [mm]$, further details can be found on drawing in Attachment C.

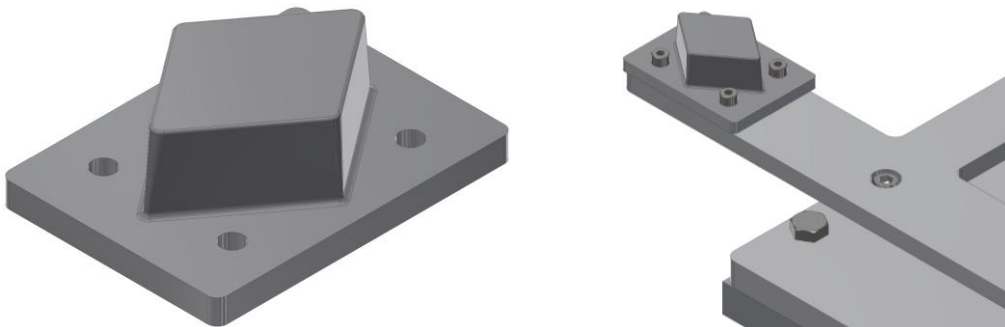

Figure 47 - Alignment bracket, 3D model and placement in assembly

3.6.4.3 Holding Bracket for Control unit

The Control unit has two predefined attachment points. During the assembly of the electric BMJ, these attachment points did not align with the Rexroth profile slots. To make sure the Control unit is attached, a holding bracket have been designed, see Figure 48. The bracket have not been analysed further, as the main function will be to hold the control unit in place. The dimensions are $LxWxH = 300x76x6 [mm]$, further details on drawing in Attachment C.

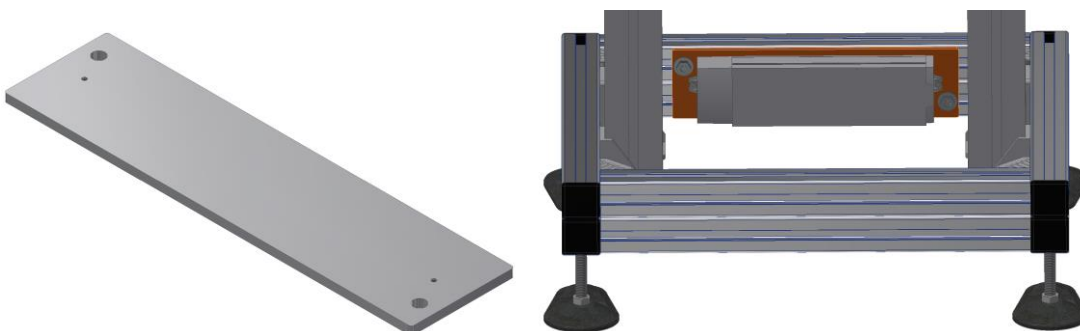

Figure 48 - Holding bracket; 3D model and placement in assembly (highlighted in orange)

4 Analysis

Different analysis have been made to the Baseplate and the Bin fitment plate (only) to ensure that the plates are within the requirements.

4.1 Material

Evaluation of possible materials were done to find the best suitable material of the different plates. The plates have similarities in shapes, size and loads, and are therefore considered equal in the material selection process. The material selection process described in the book “Material selection in mechanical design” by Michael F. Ashby have been used, together with the software Granta EduPack 2022 R2, v.22.2.2.

The material selection process consist of the following items:

1. Set design requirements
2. Derive the material index, M
3. Find the best materials

4.1.1 Design Requirements

The design requirements can be seen in Table 16 below.

Table 16 - Design requirements of plates

Function	Support plates for lift modules and Bins
Constraints	Length L and width b specified
	Deflection – must withstand the specified load (bending)
	Moment – no rotation allowed
	Temperature range (20 – 23°C)
	Life time (5+ years)
	Deviation of maximum 0.1 mm in X-, Y-, Z-directions
	Sustainability – use known parts
	Prototyping – cost effective
Objectives	Minimize mass, m
Free variable	Choice of material
	Thickness, h

4.1.2 Derive Material Index

The material index can be found via the objective function which describes the mass of the plate in the following way (Ashby, 2017, p. 118):

$$m = AL\rho = bhL\rho$$

The bending stiffness S of the plates must be at least S^* (Ashby, 2017, p. 118):

$$S = \frac{C_1 EI}{L^3} \geq S^*, \quad \text{where } I = \frac{bh^3}{12}$$

$$S = h^3 \geq \left(\frac{12S^*}{C_1 b}\right) (L^3) \left(\frac{1}{E}\right)$$

$$S = h \geq \left(\frac{12S^*}{C_1 b}\right)^{\frac{1}{3}} L \left(\frac{1}{E^{\frac{1}{3}}}\right)$$

Inserted the bending stiffness S into the objective function to eliminate h gives:

$$m = bhL\rho = \left(\frac{12S^*}{C_1 b}\right)^{\frac{1}{3}} (bL^2) \left(\frac{\rho}{E^{\frac{1}{3}}}\right)$$

Where:

- $\left(\frac{12S^*}{C_1 b}\right)^{\frac{1}{3}}$ is the functional constraint,
- (bL^2) is the geometric constraints,
- $\left(\frac{\rho}{E^{\frac{1}{3}}}\right)$ is the material properties

All quantities, except of the material, is specified. The best material for a light, stiff plate are those with the largest value of the material index M_p :

$$M_p = \frac{E^{\frac{1}{3}}}{\rho}$$

The material selection charts are on logarithmic scale. The slope of the guideline is found in the following way:

$$\log M_p = \frac{1}{3} \log E - \log \rho \rightarrow \log E = 3 \log M_p + 3 \log \rho$$

Thus, the slope of the guide line is equal to 3, where Young's modulus ($\log E$) is the y-axis and density ($\log \rho$) is the x-axis.

4.1.3 Find Materials by Properties

To find suitable materials, Granta EduPack was used. A selection project was created with database “Level 3”. A Density/Young’s Modulus chart with a guide line of slope 3 was added. Several constraints were added as limits, see the bullet list below. The results were thereafter filtered based on the material index value. The results are shown in Figure 49 & Figure 50.

See below for added limits, based on requirements in Table 2.

- Form: Bulk material,
- Material family: All, except; fluids, gases, biological and thermoset/rubber
- Toughness (G): Minimum 1 kJ/m^2
- Service temperatures: $20^\circ\text{C} - 23^\circ\text{C}$
- Metal cold and hot forming: Acceptable, Excellent (chosen due to requirements of known production processes)
- Price: Maximum 100 NOK/kg (limit set due to prototyping constraint)

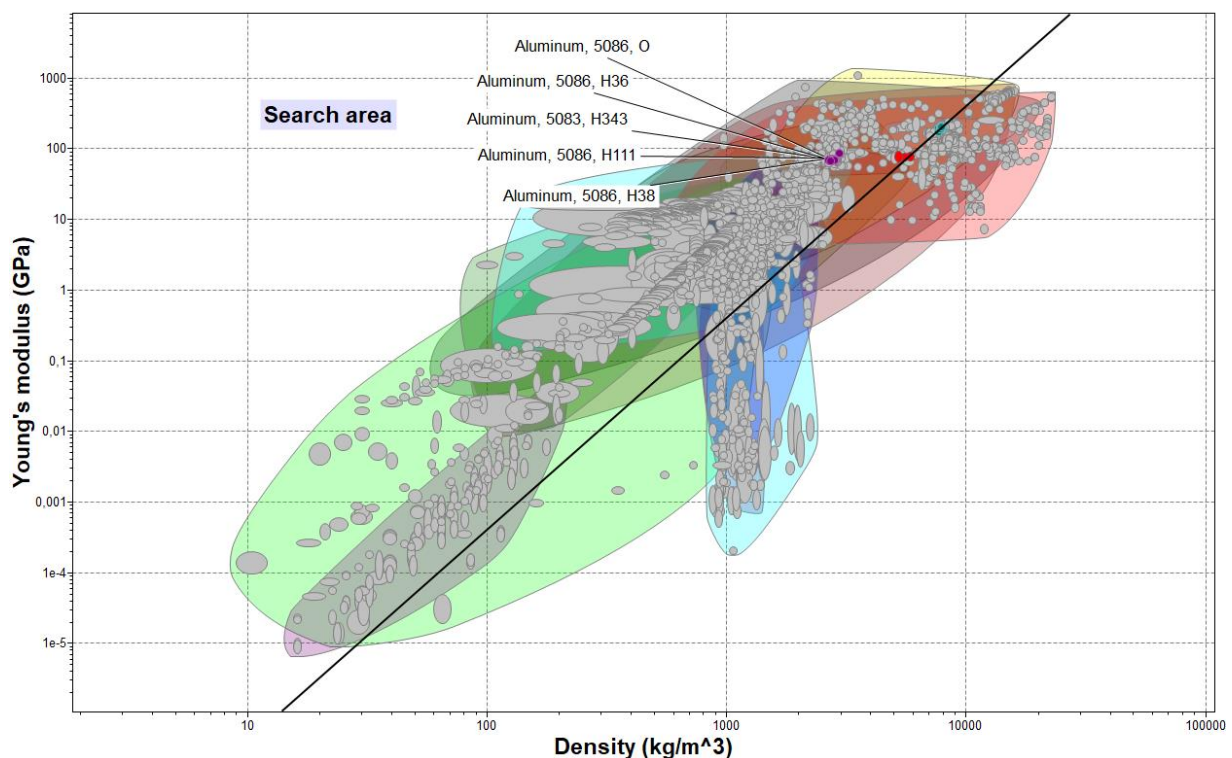

Figure 49 - Material selection chart, first five results are named on chart (GrantaEduPack)

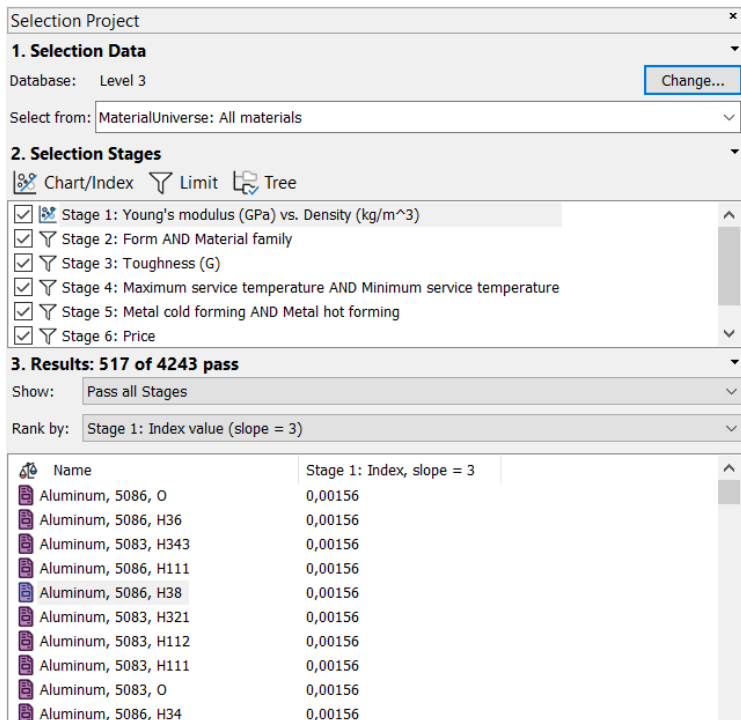

Figure 50 - Passed materials ranked by index, first 10 results (Granta EduPack)

The best material is the material with the highest material index. From Figure 50, different alloys of Al-5086 and Al-5083 are shown. They have all the same index value. When looking into the composition of the materials, there are few differences, likewise with the mechanical properties. Therefore, any of these materials will be a good choice.

4.1.4 Find Materials by Component Definition

In Granta EduPack, there is a possibility to derive materials based on component definitions. Another chart was added to the active project with the parameter “Mass per unit of stiffness” on the Y-axis to verify the previous results. All active constraints from the previous material selection in Chapter 4.1.3 was kept. The setup of the chart is seen in the bullet list below, and the results are shown in Figure 51 and Figure 52.

- Function and loading: Panel in bending
- Free variables: Thickness
- Fixed variables: length, width
- Limiting constraint: stiffness
- Optimize: mass

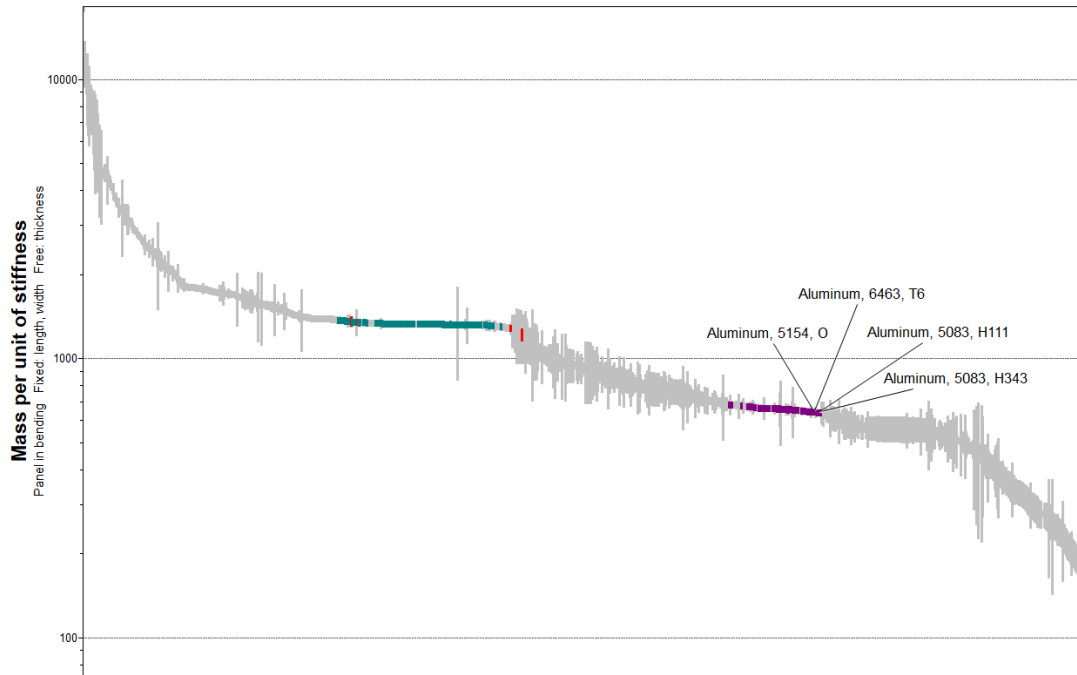

Figure 51 - Material selection mass/stiffness chart, one material per material group of the first 15 ranked materials are named on the chart (Granta EduPack)

Selection Project	
1. Selection Data	
Database:	Level 3 Change...
Select from:	MaterialUniverse: All materials
2. Selection Stages	
<input checked="" type="checkbox"/> Chart/Index <input type="checkbox"/> Limit <input type="checkbox"/> Tree	
<input checked="" type="checkbox"/>	Stage 1: Young's modulus (GPa) vs. Density (kg/m ³)
<input checked="" type="checkbox"/>	Stage 2: Form AND Material family
<input checked="" type="checkbox"/>	Stage 3: Maximum service temperature AND Minimum service temperature
<input checked="" type="checkbox"/>	Stage 4: Metal cold forming AND Metal hot forming
<input checked="" type="checkbox"/>	Stage 5: Price AND Toughness (G)
<input checked="" type="checkbox"/>	Stage 6: Mass per unit of stiffness
3. Results: 515 of 4243 pass	
Show:	Pass all Stages
Rank by:	Stage 6: Mass per unit of stiffness
Name	Mass per unit of stiffness
<input checked="" type="checkbox"/> Aluminum, 6463, T4	632 - 650
<input checked="" type="checkbox"/> Aluminum, 6463, T6	632 - 650
<input checked="" type="checkbox"/> Aluminum, 5154, H14	632 - 650
<input checked="" type="checkbox"/> Aluminum, 5154, H12	632 - 650
<input checked="" type="checkbox"/> Aluminum, 5154, O	632 - 650
<input checked="" type="checkbox"/> Aluminum, 5086, H38	633 - 646
<input checked="" type="checkbox"/> Aluminum, 5086, H36	633 - 646
<input checked="" type="checkbox"/> Aluminum, 5086, H34	633 - 646
<input checked="" type="checkbox"/> Aluminum, 5086, O	633 - 646
<input checked="" type="checkbox"/> Aluminum, 5086, H112	633 - 646
<input checked="" type="checkbox"/> Aluminum, 5086, H111	633 - 646
<input checked="" type="checkbox"/> Aluminum, 5083, O	633 - 646
<input checked="" type="checkbox"/> Aluminum, 5083, H343	633 - 646
<input checked="" type="checkbox"/> Aluminum, 5083, H323	633 - 646
<input checked="" type="checkbox"/> Aluminum, 5083, H321	633 - 646

Figure 52 - Results, passed materials ranked by mass/stiffness, first 15 results (Granta EduPack)

From the results in Figure 52, there are small variation in the results. Al-6463 and Al-5154 are on top with a range between 632-650 mass per unit of stiffness, while Al-5086 and Al-5083

have a range of 633-646. All materials passes all stages, and with the small variation in the results, any of these materials will be a good choice.

4.1.5 Choice of Material

Since all mentioned materials passes all stages, any of them is a good choice. However, the parts are modelled in Autodesk Inventor where only Al-5083 is predefined, see Figure 53.

Therefore, Al-5083 is the chosen material. A general overview of properties is given in Table 17. Material data sheets are added in Attachment A.

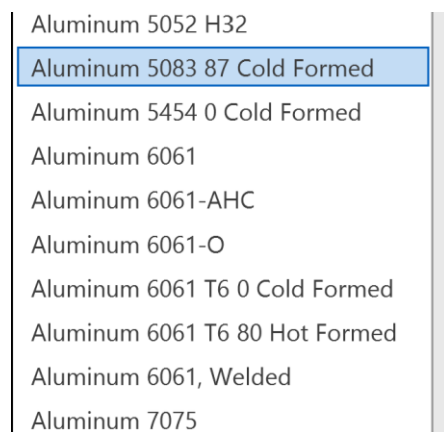

Figure 53 - Autodesk material library



Table 17 - Mechanical properties, Aluminium 5083

Youngs Modulus	69 GPa
Shear Modulus	25940 MPa
Density	$2.66 * 10^3 \text{ kg/m}^3$
Poisson's ratio	0.33
Yield strength	285 MPa
Tensile strength	385 MPa

4.2 Geometric Variations

The plates will be made of standard aluminium sheets. However, it is possible to adjust the shape, or the geometry of the plates. The Bin fitment plate is possible to vary to achieve different force distributions, see suggestions (Figure 54, Figure 55, and Figure 56) in Table 18 below. All suggestions have the same area of $L \times W = 410 \times 340 \text{ [mm]}$. The baseplate is not analysed further in regards the shape than previously described.

Table 18 - Shape suggestions, plates

Geometry	X-shaped	H-shaped	O-shaped
Figure	 <p>Figure 54 - Bin fitment plate, X-shaped</p>	 <p>Figure 55 - Bin fitment plate, H-shaped</p>	 <p>Figure 56 - Bin fitment plate, O-shaped</p>
Force distribution baseplate	More force will be moved to the middle of the baseplate.	Force distribution along the outer rim of the baseplate.	Force will be moved closer towards the lift modules.
Advantages	Minimum mass.	Better force distribution.	Reduce possible risk of twisting at edges.

4.3 Stress Analysis

All shapes from the previous chapter will be stress analysed in Inventor Professional 2022, release version 2022.4.1, to find the best shape for the Bin fitment plate. Before the stress analysis takes place, some parameters were settled, see Table 19. Examples of how loads and constraints were applied can be seen in Figure 57. The load scenario on the baseplate is adjusted for each shape of the Bin fitment plate. The Bin fitment plate is analysed with a real life scenario (when measuring/scanning the Bin) with constraints where there is surface contact with the baseplate. The results are presented in Table 20, with results examples in Figure 58 and Figure 59. Full setups and results can be seen in Attachment B.

Table 19 – Parameters stress analysis

	Baseplate	Bin fitment plates
Thickness, h^*	6mm	8mm
Weight W	~1kg	~1kg
Force F applied	~120N	4 * 30N = 120N
Load scenario**	Distributed on surface contact with fitment plates, generating three different load scenarios	Evenly distributed areas (65x40 mm) in each corner.

Constraints**	Contact with lift modules	Surface contact with baseplate.
---------------	---------------------------	---------------------------------

*Suggestions – minimum thickness without conflicts with bolts/nuts during assembly.

**An extrusion/cut of 0.01mm thickness on affected areas has been performed on the models to generate realistic scenarios. See features in Attachment B.

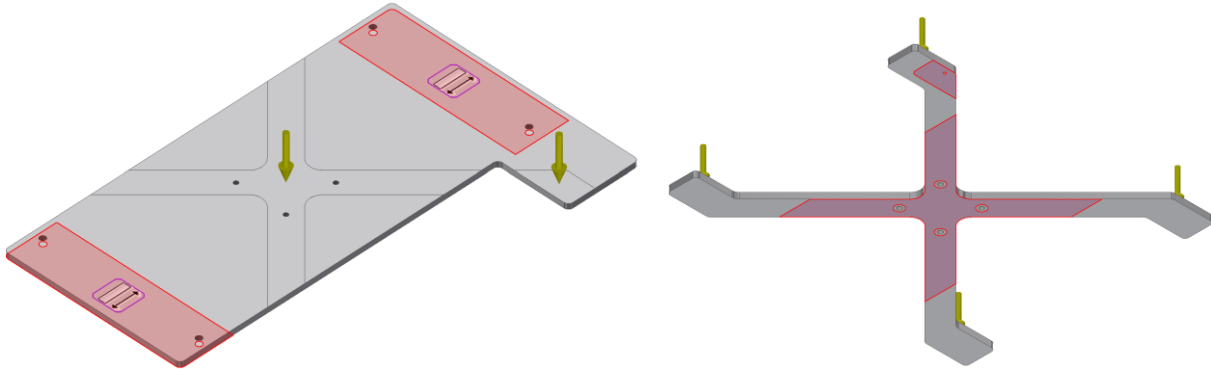

Figure 57 - Load (yellow arrows) and constraints (red areas) on Baseplate and X-shaped Bin fitment plate

Table 20 - Results stress analysis

		X-shape	H-shape	0-shape
Bin fitment plate	Von Mises stress	9.934 MPa	11.3 MPa	5.066 MPa
	Displacement	0.1303 mm	0.07465 mm	0.5114 mm
Baseplate	Von Mises stress	4.654 MPa	3.204 MPa	2.915 MPa
	Displacement	0.4339 mm	0.3188 mm	0.8015 mm

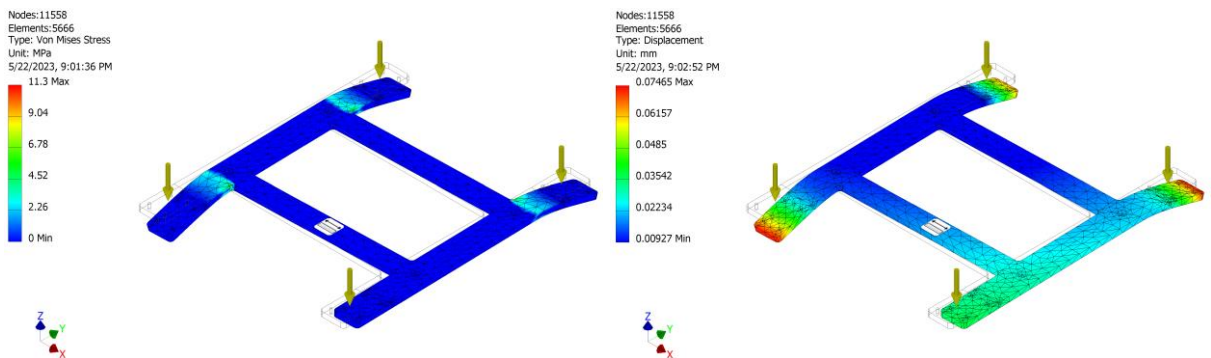

Figure 58 - Results H-shape; Von Mises stress and displacement

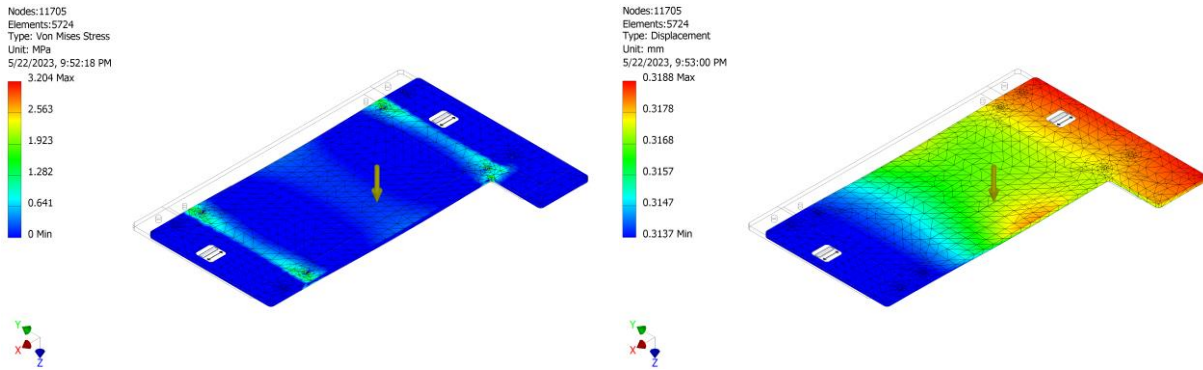

Figure 59 - Results H-shape on baseplate; Von Mises stress and displacement

As seen from the results in Table 20, the H-shaped Bin fitment plate has the lowest displacement with 0.07465 mm. The corresponding results for the H-load scenario on the baseplate show a displacement of 0.3188 mm, which is out of the 0.1 mm tolerance given in the requirements. To verify the results, both plates have been stress analysed with refined meshes. All other parameters remained the same. The results in Table 21 tells that both plates will be within specifications when refining the mesh. See Figure 60 for additional coloured maps for the displacements with the finest mesh. Full results is shown in Attachment B.

Table 21 - Baseplate thickness iteration results with H-shape load scenario

		Mesh 0.05	Mesh 0.01	Mesh 0.005
Bin fitment plate	Von Mises stress	11.3 MPa	30.92 MPa	7.703 MPa
	Displacement	0.07465 mm	0.1216 mm	0.07042 mm
Baseplate	Von Mises stress	3.204 MPa	3.68 MPa	5.876 MPa
	Displacement	0.3188 mm	0.08279 mm	0.03235 mm

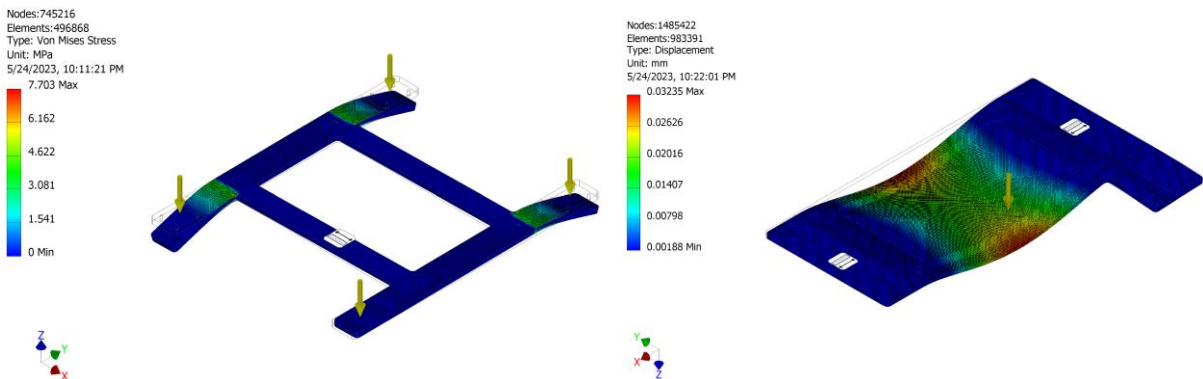

Figure 60 - Bin fitment plate and baseplate, mesh 0.005, results displacement

5 Final Product

The final BMJ (Bin measuring jig) can be seen in Figure 61 & Figure 62. The position shown is with lift modules extended 200 (of 410) mm. Drawings can be found in Attachment C. The figures and drawings does only show mechanical parts and electric modules. Cables and accessories (i.a. cable clamps) are not shown nor presented in the BOM list. The dimensions of the final product, when the length and width of the oval feet are neglected, are $L \times W \times H = 530 \times 450 \times 820/1230$ (height adjustment with lowest/highest positions).

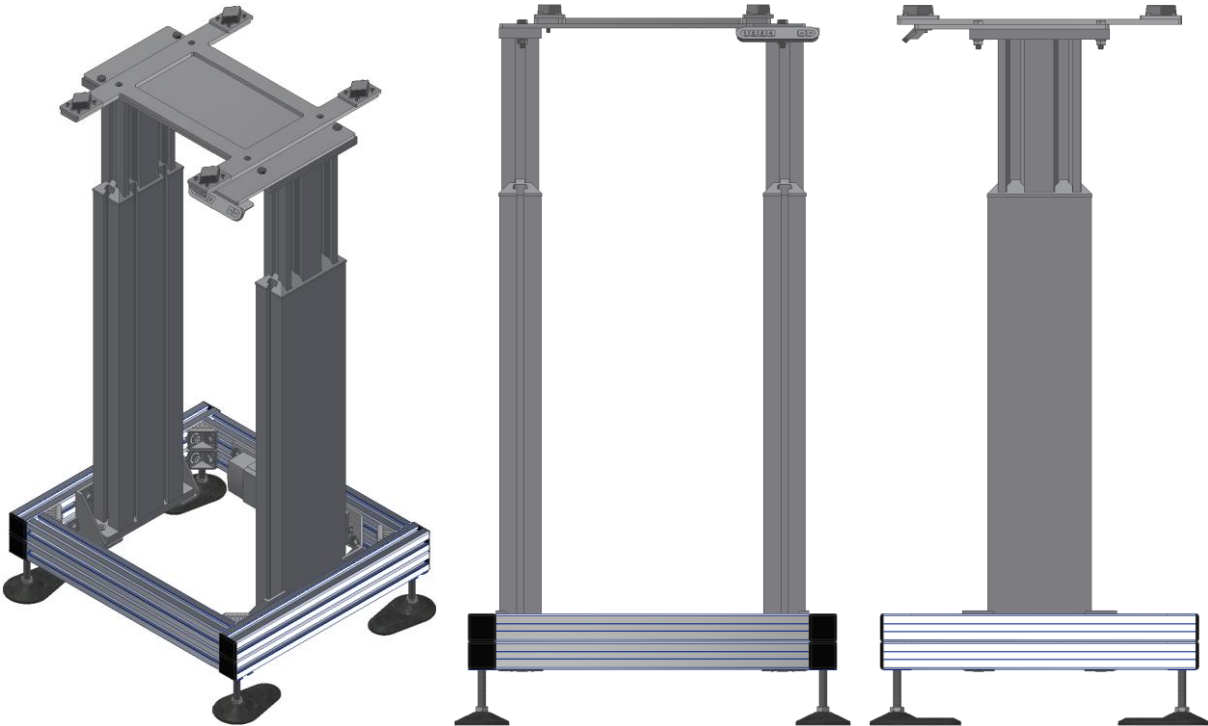

Figure 61 - Final product, 3D view, front- and right views

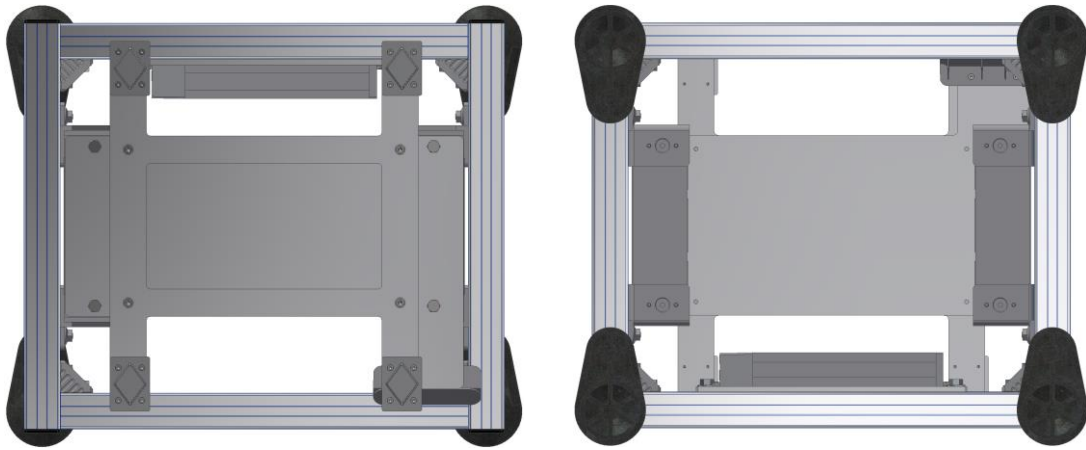

Figure 62 - Final product, top- and bottom views

The final BMJ is built with standard Rexroth components combined with specially designed parts. The specially designed parts offers a simple design for manufacturing, with parts in standard sheet thicknesses and features which are easy to make. The BMJ has an ergonomic design with the height adjusting lift modules. Buttons are located on the top of the lift module for easy operation. The setup is easy to assemble, with few parts, and is easy configurable for other fitment plates or brackets if necessary. The BMJ can be placed where needed, and should be within the arm reach of the CMM equipment, see an example placement in Figure 63.

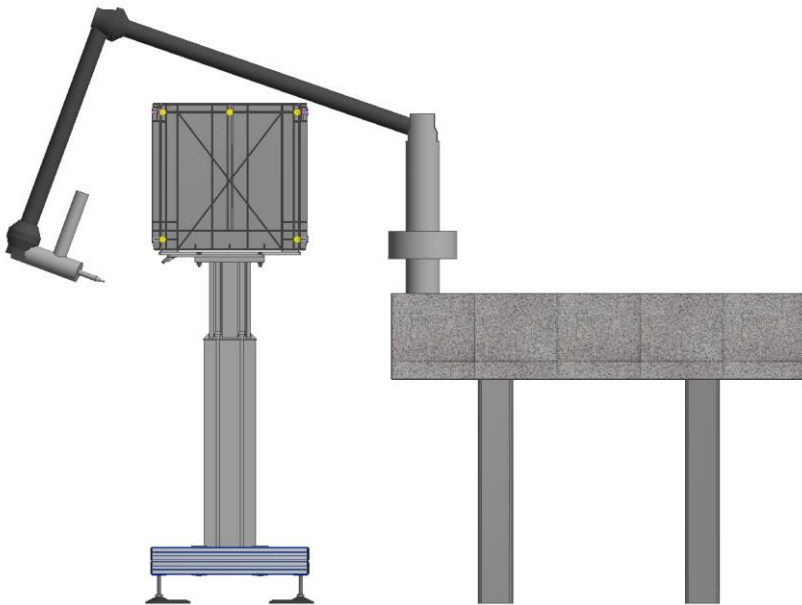

Figure 63 - BMJ placed within the reach of the measuring arm, front view. The jig is height adjusted 200mm and has a 425 Bin attached.

6 Discussion and Further Work

6.1 Discussion

6.1.1 How do the Results Correspond with the Problem Description?

This project focused on developing an internal measuring jig, tailor-made for scanning AutoStore Bins. Today's setup requires two scans which creates more work than necessary. In addition, the setup does not offer any customizations, which challenges the ergonomics. The project answers the problem, with a better ergonomic measuring jig where all measurements can be scanned in one go. This makes it better and faster for the operator to scan Bins.

6.1.2 Compared with Similar Solutions or Other Setups

The current setup at AutoStore consists of a granite table with the Hexagon arm mounted directly on the table. This setup excludes possible variations, both ergonomic and placement of Bins, as the Bins need to be placed correctly on the table for the arm reach. This is especially tricky with the 425 Bin, due to the height.

Another setup is to place the Hexagon CMM arm on a height adjusting tripod. Anyways, when placing Bins on the granite table, it challenges the ergonomics as well as the main problem; it is not possible to scan the underside of the Bins (b-scan) together with the top scan (a-scan). External scans of the Bins show that, even though they create one report from the two scans, there are troubles with alignment of the measurements. Aligning the scans is therefore excluded as an option and is not relevant.

AutoStore Bins are highly technical and customized products. There are no commercial jig or other setups created for the specific use described in this project.

6.1.3 Evaluation of Reliability and Validity

There are several analyses done on the customized parts of the BMJ. The results are reliable as the program inputs are based on the specifications and requirements given. The results are valid for the final setup of the jig only. If further customizations or other choices of materials are done, new analysis needs to be run. The customized plates should have been made in the same thickness to avoid additional cost for buying two different sheets, even though it was not necessary based on stress analysis.

The standard Rexroth parts have not been investigated for choice of material or stress analysis. Rexroth parts are made in a specific aluminium material, with a design that is over-engineered for this project's load scenario. No analysis was therefore done, however, technical data sheets of the construction parts used can be found in Attachment D.

6.2 Further Work

6.2.1 Required Further Work

This project has focused on developing a measuring jig for the AutoStore Bins. The measuring jig meets the requirements settled. However, since it is now possible to scan the Bins in one scan, with all measurements, there are some internal work that need to be done.

This includes:

- A solution for cables and accessories to be developed,
- Testing and verification of the BMJ,
- Make a new scan program with all measurements to be extracted,
- Make a new scan report (with all measurements in one report),
- Update internal guidelines

6.2.2 Alignment Brackets

For the alignment brackets, only one design has been developed. The design fits all current AutoStore Bins. However, it is based on aligning the sandwich structure on the bottom of the bins. It is possible to develop other brackets for easier alignment or operation. Some examples are listed below:

- Flat brackets with a larger area/footprint,
- Structured brackets with more structure to better hold the bins in place,
- Locking brackets for the bottom rim (the measurement on the bottom rim will be disturbed)

6.2.3 Manual Version

The final BMJ is developed with electric handling with lift modules. The lift modules are not standard shelf items at AutoStore, thus the manual version might be a better option to try the concept. If the manual version will be the first assembled version of the BMJ, the following work should be done:

- Develop a better ergonomic design of the height adjustment,
- Height adjustment components to be reviewed and analysed (calculate force/moment, rigidity of system, amount of rails/guides/locks etc.)

7 Conclusion

The Bin measuring jig is a new internal AutoStore jig, made especially for the CMM scanning of the Bins. The jig is designed to be within the reach of the existing Hexagon arm, and can be placed where needed.

The final product is made of standard Rexroth parts and height adjustment modules paired with specially designed baseplate and Bin fitment plate with brackets to keep the bins in place. The method used ensures that several aspects of the design process is taken into consideration. A short summarize of the process is listed below:

1. Clarification of objectives (objectives/limitations set by customer and structured into higher and lower ranked items).
2. Determining characteristics (to give a better understanding of the product development with customer attributes connected to engineering attributes).
3. Generating alternatives (alternatives created and placed into different categories).
4. Evaluating (ranked by relative weight method).
5. Detailing (further development created two solution concepts; manual and electric, where the electric version was developed further based on the customer inputs).
6. Analysing (analysing and adapting the different parts for an optimal assembled solution without sacrificing important parameters).

The Bin measuring jig is a simple, ergonomic and safe jig to use and operate. The assembly of the jig is based on using common tools and there are relatively few parts – making it easier to assemble. The design opens up for further customizations with easy exchange of the Bin fitment plate and alignment brackets. The jig is sturdy and reliable.

References

- AJ Produkter. (2023). *U-bord* [Illustration]. <https://www.ajprodukter.no/lager-og-verksted/lofteutstyr/loftebord/loftebord-lav-u-profil/u-bord-412396-412394>
- Ashby, M. F. (2017). *Materials selection in mechanical engineering* (5th ed.). Elsevier Ltd.
- AutoStore. (2023). *Automation made easy*. <https://www.autostoresystem.com/system>
- AutoStore. (2023). *Bins*. [Illustration]. <https://www.autostoresystem.com/system/bins>
- AutoStore. (2023). *Bins – spec sheet*. [Brochure]. <https://www.autostoresystem.com/system/bins>
- AutoStore. (2023). *The Robots*. [Illustration]. <https://www.autostoresystem.com/system/robots>
- AutoStore. (2023). *Workstations (ports)*. [Illustration]. <https://www.autostoresystem.com/system/workstations>
- Bins. (2021). *Hvorfor bins?* [Illustration]. <https://bins.no/>
- Bosch Rexroth. (2022). *Lineær bevegelse* [Illustration]. <https://www.boschrexroth.com/nb/no/produkter/produktgrupper/lineaer-bevegelsesteknologi/>
- Bosch Rexroth. (2022). *Basic mechanical elements*. [Illustration]. https://store.boschrexroth.com/Assembly-Technology/Basic-Mechanic-Elements?cclcl=nb_NO&cartId=1c4cdf8f-16a3-49e1-b6ae-d691f6b29f12&reloaded=true
- Bosch Rexroth. (2023). *Clamping element HK 3005*. [Illustration]. https://store.boschrexroth.com/CLAMPING-ELEMENT_R161974282?cclcl=da_GL
- Creaform. (2021, March 3). *What is a CMM?* <https://www.creaform3d.com/blog/what-is-cmm-and-their-types/>

Deutsches Institut für Normung. *Plastic moulded parts – Tolerances and acceptance conditions* (DIN-16742:2013-10). <https://www.beuth.de/en/standard/din-16742/192658755>

Hexagon. (2022). *Absolute tracker system and accessories*. [Brochure].
<https://hexagon.com/resources/resource-library/forms/absolute-tracker-product-catalogue-en>

Hexagon. (2023, January 22). *The Absolute Arm range*.
<https://hexagon.com/resources/resource-library/forms/absolute-arm-rl12-1288>

Mauseth, G. B. (2022, January). *Product Design 2022 notes*. Presented at The University of Tromsø, Narvik, Norway.

Maxtech. (2022). *Hydraulisk jekk universal 5 tonn*. [Illustration].
<https://www.maxtech.no/products/hydraulisk-jekk-universal-5-tonn>

THK. (2023). *Linear motion guide*. [Illustration]. <https://www.thk.com/?q=eng/node/22647>

Attachments

- A. Material datasheets
- B. Stress analysis results
- C. Drawings final design
- D. Datasheets Rexroth
- E. Drawing manual version
- F. Problem description
- G. Schedule

General information

Designation

Aluminum, 5083, H111, wrought

Condition	H111 (Strain-hardened only)
UNS number	A95083
EN name	EN AW-5083 (EN AW-Al Mg4,5Mn0,7)
EN number	3.3547

Tradenames

Airco; Alcan; Hydronalium

Typical uses

Marine, auto, and aircraft applications, unfired welded pressure vessels, cryogenics, TV towers, drilling rigs, transportation equipment, missile components, armor plate. Applications requiring a weldable moderate-strength alloy having good corrosion resistance, LED light bulbs

Included in Materials Data for Simulation	✓
Materials Data for Simulation name	Aluminum alloy, wrought, 5083, H111

Composition overview

Compositional summary

Al92-96 / Mg4-4.9 / Mn0.4-1 / Cr0.05-0.25 (impurities: Fe<0.4, Si<0.4, Zn<0.25, Ti<0.15, Cu<0.1, Other<0.15)

Material family	Metal (non-ferrous)
Base material	Al (Aluminum)

Composition detail (metals, ceramics and glasses)

Al (aluminum)	* 92,4	-	95,6	%
Cr (chromium)	0,05	-	0,25	%
Cu (copper)	0	-	0,1	%
Fe (iron)	0	-	0,4	%
Mg (magnesium)	4	-	4,9	%
Mn (manganese)	0,4	-	1	%
Si (silicon)	0	-	0,4	%
Ti (titanium)	0	-	0,15	%
Zn (zinc)	0	-	0,25	%
Other	0	-	0,15	%

Price

Price	* 18	-	20,8	NOK/kg
Price per unit volume	* 4,77e4	-	5,55e4	NOK/m ³

Physical properties

Density	2,64e3	-	2,67e3	kg/m ³
---------	--------	---	--------	-------------------

Mechanical properties

Young's modulus	70	-	73,6	GPa
Young's modulus with temperature	70	-	70	GPa

[Parameters:](#) Temperature = 23°C

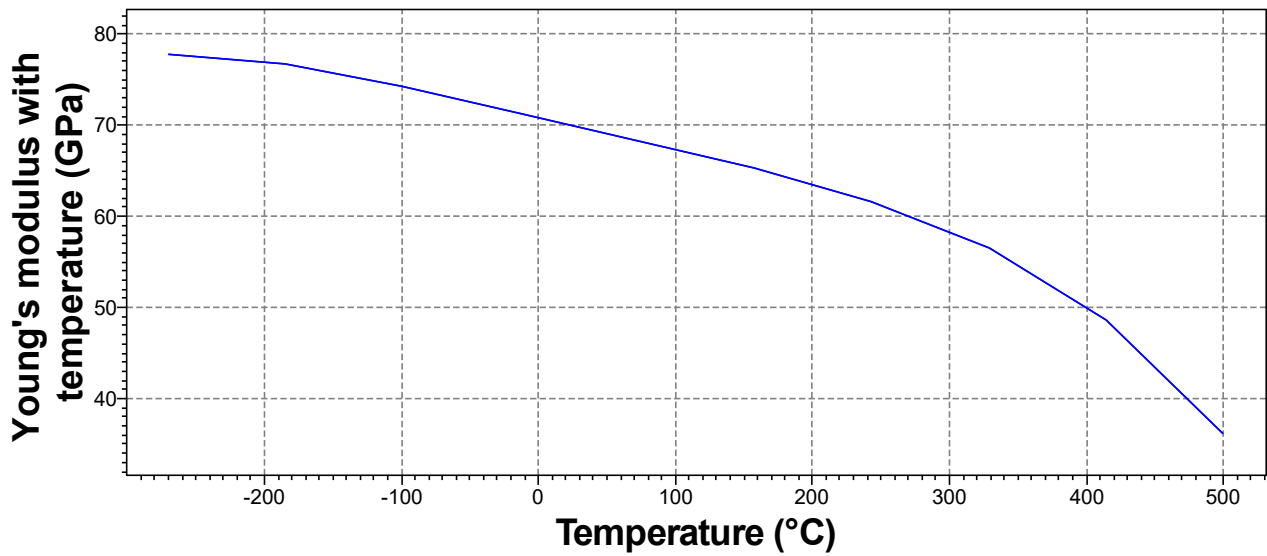

Specific stiffness	26,3	-	27,7	MN.m/kg
Yield strength (elastic limit)	131	-	165	MPa
Tensile strength	221	-	276	MPa
Specific strength	49,3	-	62,1	kN.m/kg
Elongation	12	-	13,9	% strain
Tangent modulus	1,01e3			MPa
Compressive strength	* 207	-	229	MPa
Flexural modulus	* 70	-	73,6	GPa
Flexural strength (modulus of rupture)	131	-	165	MPa
Shear modulus	23	-	24,2	GPa
Bulk modulus	69	-	72,5	GPa
Poisson's ratio	0,33	-	0,343	
Shape factor	36			
Hardness - Vickers	* 71	-	79	HV
Elastic stored energy (springs)	121	-	188	kJ/m ³
Fatigue strength at 10 ⁷ cycles	* 122	-	152	MPa
Fatigue strength model (stress amplitude)	* 108	-	172	MPa

[Parameters:](#) Stress Ratio = -1, Number of Cycles = 1e7cycles

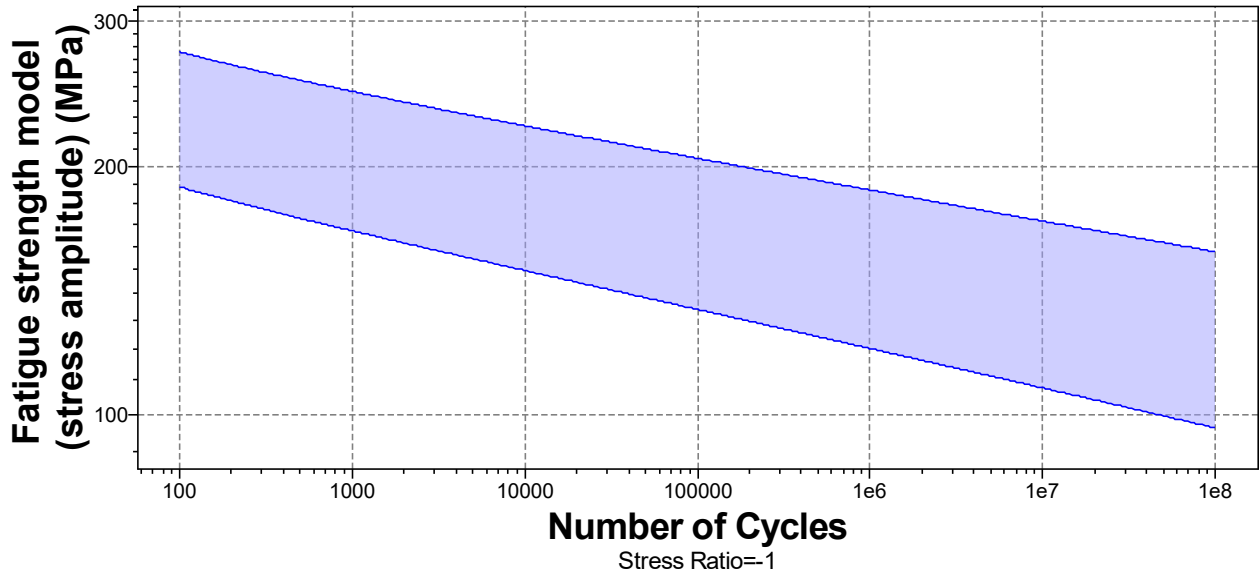

Impact & fracture properties

Fracture toughness	* 27	-	37	MPa.m ^{0.5}
Toughness (G)	* 10,4	-	18,7	kJ/m ²

Thermal properties

Melting point	574	-	638	°C
Maximum service temperature	80	-	100	°C
Minimum service temperature	-273			°C
Thermal conductivity	118	-	128	W/m.°C
Specific heat capacity	963	-	1e3	J/kg.°C
Specific heat capacity with temperature	948	-	948	J/kg.°C

[Parameters:](#) Temperature = 23°C

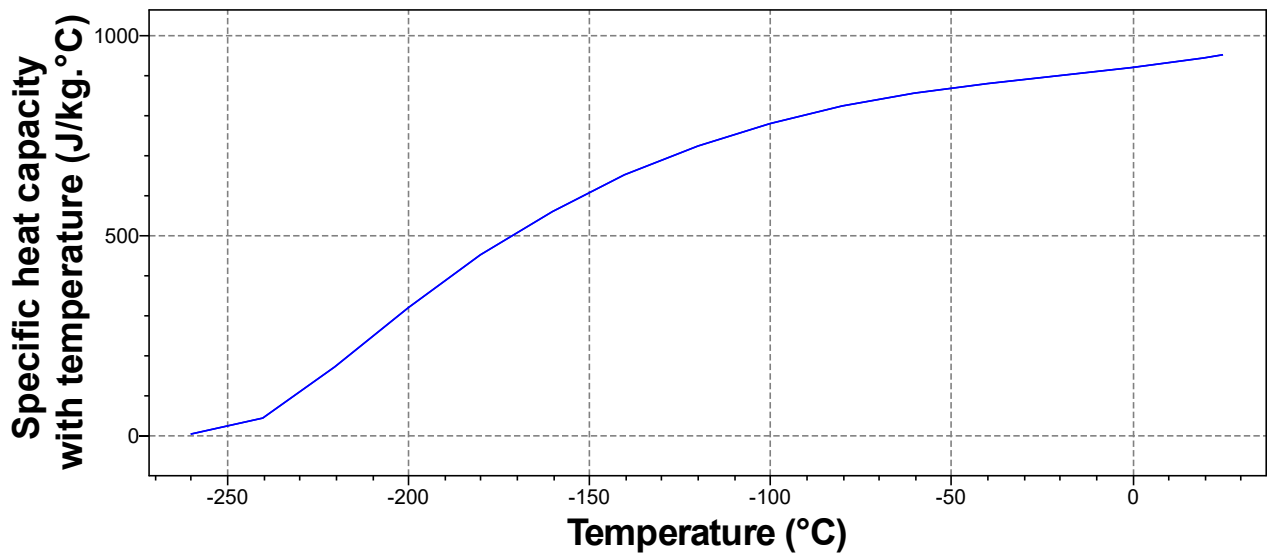

Thermal expansion coefficient	23,6	-	24,8	µstrain/°C
Thermal expansion coefficient with temperature	22,8	-	22,8	µstrain/°C

Values marked * are estimates.
ANSYS, Inc. provides no warranty for this data.

[Parameters:](#) Temperature = 23°C

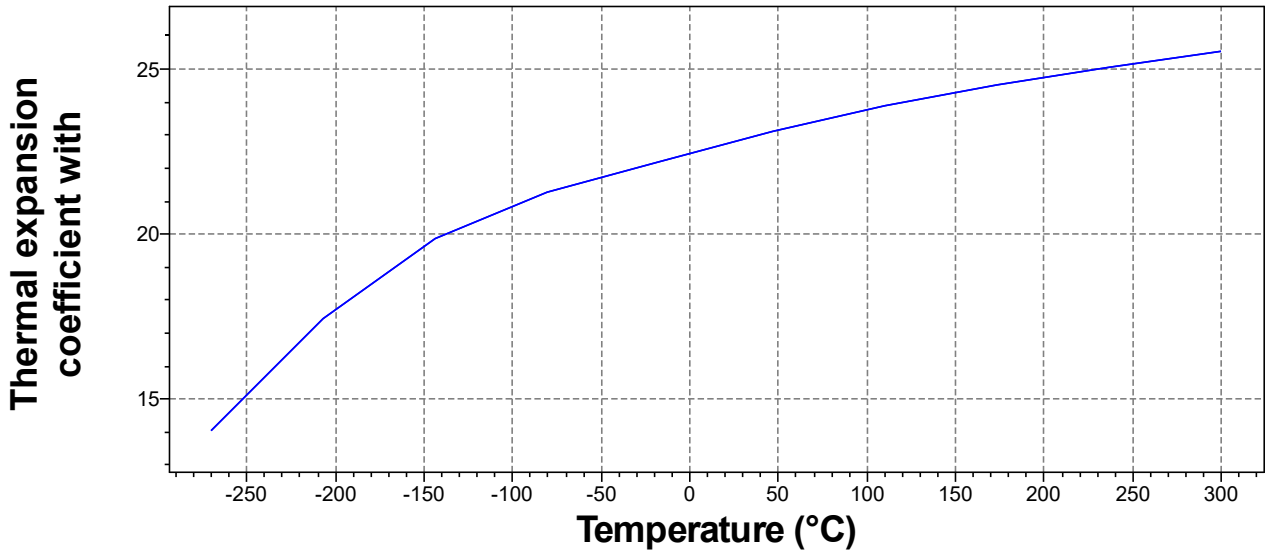

Reference temp	20		°C
Thermal shock resistance	75,1	-	95,5 °C
Thermal distortion resistance	4,83	-	5,31 MW/m
Latent heat of fusion	384	-	393 kJ/kg

Electrical properties

Electrical resistivity	5,85	-	6,05 μohm.cm
Electrical resistivity with temperature	5,92		μohm.cm

[Parameters:](#) Temperature = 23°C

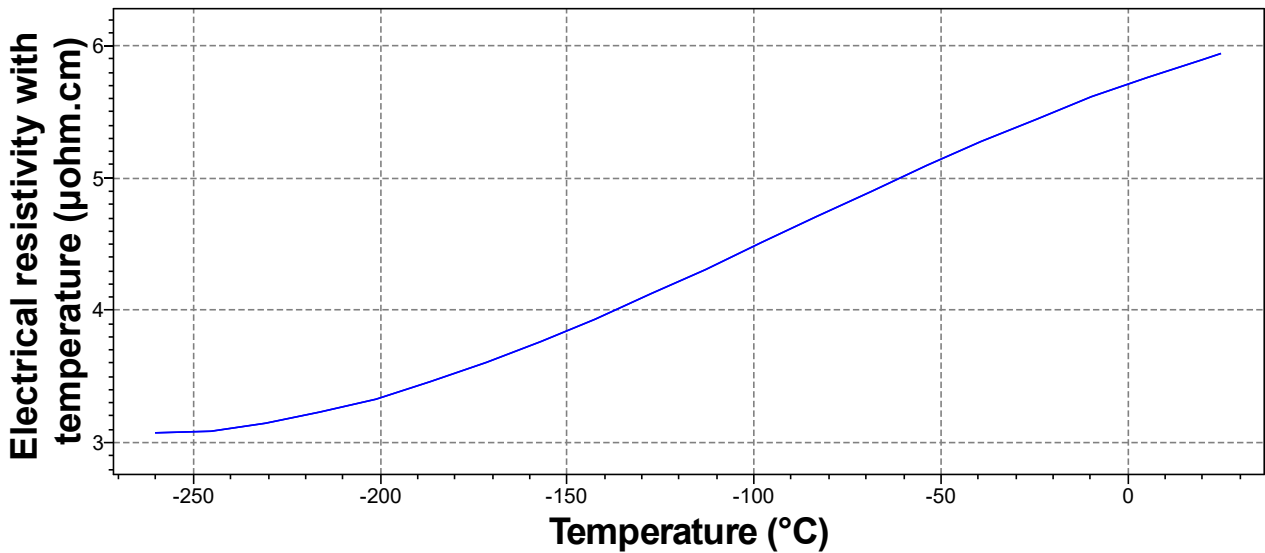

Electrical conductivity	28,5	-	29,5 %IACS
Electrical conductivity with temperature	1,69e7		Siemens/m

[Parameters:](#) Temperature = 23°C

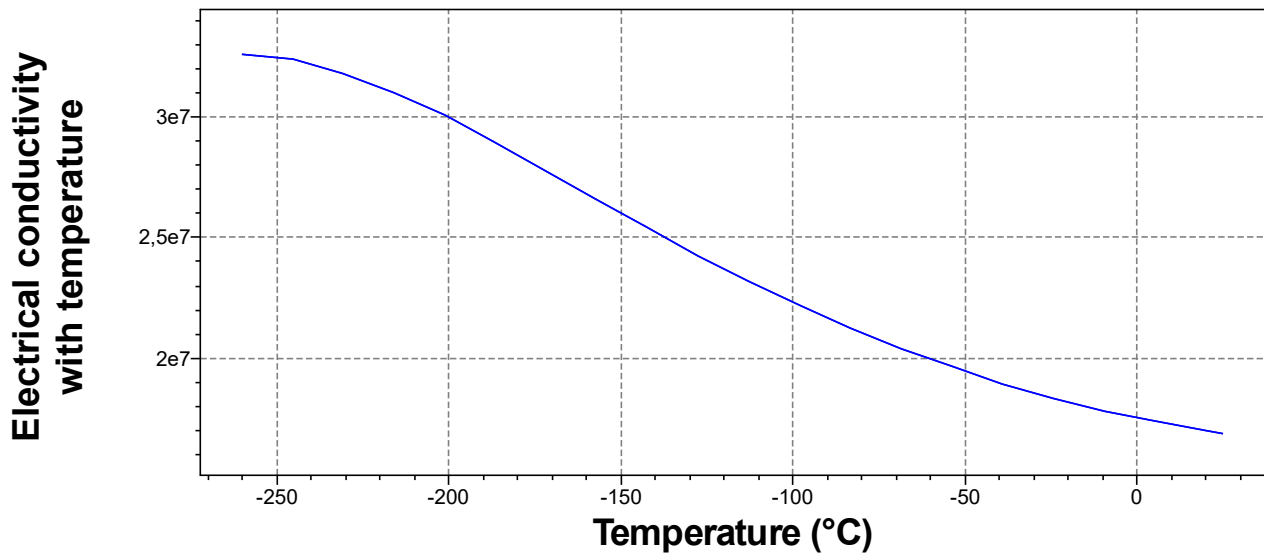

Galvanic potential	* -0,83	-	-0,75	V
--------------------	---------	---	-------	---

Magnetic properties

Magnetic type	Non-magnetic
---------------	--------------

Optical, aesthetic and acoustic properties

Transparency	Opaque
Acoustic velocity	5,13e3 - 5,26e3 m/s
Mechanical loss coefficient (tan delta)	* 1e-4 - 0,002

Critical materials risk

Contains >5wt% critical elements?	Yes
-----------------------------------	-----

Processing properties

Metal casting	Unsuitable
Metal cold forming	Excellent
Metal hot forming	Acceptable
Metal press forming	Excellent
Metal deep drawing	Acceptable
Machining speed	168 m/min
Weldability	Excellent
Notes	Preheating and post weld heat treatments are not required

Durability

Water (fresh)	Excellent
Water (salt)	Acceptable
Weak acids	Excellent
Strong acids	Excellent
Weak alkalis	Acceptable
Strong alkalis	Unacceptable
Organic solvents	Excellent
Oxidation at 500C	Unacceptable
UV radiation (sunlight)	Excellent

Values marked * are estimates.
ANSYS, Inc. provides no warranty for this data.

Galling resistance (adhesive wear)	Limited use
------------------------------------	-------------

Notes

Aluminum alloys perform poorly when self-mated but can be processed without galling when mated with steels.

Flammability	Non-flammable
--------------	---------------

Corrosion resistance of metals

Stress corrosion cracking	Susceptible
---------------------------	-------------

Notes

Rated in chloride; Other susceptible environments: Halide, water

Primary production energy, CO2 and water

Embodied energy, primary production (virgin grade)	* 192	-	212	MJ/kg
--	-------	---	-----	-------

Sources

Estimated from sources including Institute for Prospective Technological Studies, 2005; Hekkert, 2000; Norgate, Jahanshahi, Rankin, 2007; Hammond and Jones, 2008; Ecoinvent v3.7.1; Dhingra, Overly, Davis, 1999

Embodied energy, primary production (typical grade)	* 117	-	137	MJ/kg
---	-------	---	-----	-------

CO2 footprint, primary production (virgin grade)	* 13,5	-	14,9	kg/kg
--	--------	---	------	-------

Sources

Estimated from sources including Voet, van der and Oers, van, 2003; Hammond and Jones, 2008; Ecoinvent v3.7.1; Tharumarajah and Koltun, 2007

CO2 footprint, primary production (typical grade)	* 8,35	-	9,74	kg/kg
---	--------	---	------	-------

Water usage	* 1,13e3	-	1,25e3	l/kg
-------------	----------	---	--------	------

Processing energy, CO2 footprint & water

Roll forming, forging energy	* 5,48	-	6,06	MJ/kg
------------------------------	--------	---	------	-------

Roll forming, forging CO2	* 0,411	-	0,454	kg/kg
---------------------------	---------	---	-------	-------

Roll forming, forging water	* 3,89	-	5,84	l/kg
-----------------------------	--------	---	------	------

Extrusion, foil rolling energy	* 10,7	-	11,8	MJ/kg
--------------------------------	--------	---	------	-------

Extrusion, foil rolling CO2	* 0,8	-	0,885	kg/kg
-----------------------------	-------	---	-------	-------

Extrusion, foil rolling water	* 6,11	-	9,17	l/kg
-------------------------------	--------	---	------	------

Wire drawing energy	* 39,2	-	43,4	MJ/kg
---------------------	--------	---	------	-------

Wire drawing CO2	* 2,94	-	3,25	kg/kg
------------------	--------	---	------	-------

Wire drawing water	* 14,8	-	22,2	l/kg
--------------------	--------	---	------	------

Metal powder forming energy	* 23,2	-	25,7	MJ/kg
-----------------------------	--------	---	------	-------

Metal powder forming CO2	* 1,86	-	2,05	kg/kg
--------------------------	--------	---	------	-------

Metal powder forming water	* 25,3	-	38	l/kg
----------------------------	--------	---	----	------

Vaporization energy	* 1,55e4	-	1,71e4	MJ/kg
---------------------	----------	---	--------	-------

Vaporization CO2	* 1,16e3	-	1,28e3	kg/kg
------------------	----------	---	--------	-------

Vaporization water	* 6,46e3	-	9,69e3	l/kg
--------------------	----------	---	--------	------

Coarse machining energy (per unit wt removed)	* 1,25	-	1,39	MJ/kg
---	--------	---	------	-------

Coarse machining CO2 (per unit wt removed)	* 0,0941	-	0,104	kg/kg
--	----------	---	-------	-------

Fine machining energy (per unit wt removed)	* 8,27	-	9,14	MJ/kg
---	--------	---	------	-------

Fine machining CO2 (per unit wt removed)	* 0,62	-	0,685	kg/kg
--	--------	---	-------	-------

Grinding energy (per unit wt removed)	* 16,1	-	17,7	MJ/kg
---------------------------------------	--------	---	------	-------

Grinding CO2 (per unit wt removed)	* 1,2	-	1,33	kg/kg
------------------------------------	-------	---	------	-------

Non-conventional machining energy (per unit wt removed)	* 155	-	171	MJ/kg
---	-------	---	-----	-------

Non-conventional machining CO2 (per unit wt removed)	* 11,6	-	12,8	kg/kg
--	--------	---	------	-------

Recycling and end of life

Recycle	✓			
---------	---	--	--	--

Embodied energy, recycling	32,6	-	36	MJ/kg
----------------------------	------	---	----	-------

CO2 footprint, recycling	2,56	-	2,83	kg/kg
Recycle fraction in current supply	42,8	-	47,3	%
Downcycle	✓			
Combust for energy recovery	✗			
Landfill	✓			
Biodegrade	✗			

Notes

Keywords

0.5083 to CSA HA.4; 0.5083 to CSA HA.5; 0.5083 to CSA HA.7; 1540 to GOST 4784; 17215 to NS 17215; 3.3547; 3.3547/AlMg4.5Mn to DIN 1725-1; 3.5354.00/AlMg4.5Mn to JUS C.C.2.100; 4140-00 to SIS 144140; 4140-02 to SIS 144140; 4140-12 to SIS 144140; 4140-22 to SIS 144140; 4140-24 to SIS 144140; 4146-00; 4146-18; 4163-00; 5 Mn; 5 Mnzr; 5083; 5083 to AMS 4056; 5083 to AMS 4057; 5083 to AMS 4058; 5083 to AMS 4059; 5083 to AS 1734; 5083 to AS 2848.1; 5083 to ASTM B209M; 5083 to ASTM B210M; 5083 to ASTM B221M; 5083 to ASTM B241M; 5083 to ASTM B247M; 5083 to ASTM B345/B345M; 5083 to ASTM B547/B547M; 5083 to BS 1470; 5083 to BS 1471; 5083 to BS 1472; 5083 to BS 1474; 5083 to DS 3012; 5083 to MIL DTL-45225F; 5083 to MIL DTL-46027J; 5083 to MIL DTL-46083D; 5083 to NBN P21-001; 5083 to NF A50-411; 5083 to NF A50-451; 5083 to QQ A-200/4; 5083 to QQ A-250/6; 5083 to QQ A-367; 5183; 54300 to IS 733; 54300 to IS 736; 55000; 5518 to AS 2848.1; A 5056; A 5086; A5083BD/W to JIS H4040; A5083BE to JIS H4040; A5083FD to JIS H4140; A5083FH to JIS H4140; A5083P to JIS H4000; A5083S to JIS H4100; A5083TD to JIS H4080; A5083TE to JIS H4080; AIRCO 5183; Alcan D54S; Alcan Wg-D 54 S; AlMg4.5Mn to MSZ 3714/1; AlMg4.5Mn to ONORM M3430; AlMg4.5Mn0.7 to ISO 209-1; AlMg4.5Mn0.7(A) to ISO 209-1; Am 40; AMg4 to GOST 4784; Birmabright Bb4; EAlMg4.5Mn to NF A81-331; EN AW-5083 (EN AW-Al Mg4.5Mn0.7); EN AW-5083 to CEN EN 573-3; EN AW-5183 to CEN EN 573-3; ER5183 to AWS A5.10/A5.10M; GM41 to CSA; Hydronalium 5; Lnm Almg 4; Lnt Almg 4; MAIMg4.5Mn to NF A81-331; R5183 to AWS A5.10/A5.10M; SAE AMS 4056; SAE AMS 4057; SAE AMS 4058; SAE AMS 4059; SAE AMS QQ A 200/4; SAE AMS QQ A 367; Sv AMg4; UNS A95083; UNS A95183

Standards with similar compositions

- Australia:
5083 to AS 1734, 5083 to AS 2848.1, 5518 to AS 2848.1
- Austria:
AlMg4.5Mn to ONORM M3430
- Belgium:
5083 to NBN P21-001
- Canada:
0.5083 to CSA HA.4, 0.5083 to CSA HA.5, 0.5083 to CSA HA.7, GM41 to CSA
- Denmark:
5083 to DS 3012
- Europe:
EN AW-5083 to CEN EN 573-3, EN AW-5183 to CEN EN 573-3
- France:
5083 to NF A50-411, 5083 to NF A50-451, EA1Mg4.5Mn to NF A81-331, MA1Mg4.5Mn to NF A81-331
- Germany:
3.3547/AlMg4.5Mn to DIN 1725-1
- Hungary:
AlMg4.5Mn to MSZ 3714/1
- India:
54300 to IS 733, 54300 to IS 736
- International:
AlMg4.5Mn0.7 to ISO 209-1, AlMg4.5Mn0.7(A) to ISO 209-1
- Japan:
A5083BD/W to JIS H4040, A5083BE to JIS H4040, A5083FD to JIS H4140, A5083FH to JIS H4140, A5083P to JIS H4000, A5083S to JIS H4100, A5083TD to JIS H4080, A5083TE to JIS H4080
- Norway:
17215 to NS 17215
- Russia:
1540 to GOST 4784, AlMg4 to GOST 4784
- Sweden:
4140-00 to SIS 144140, 4140-02 to SIS 144140, 4140-12 to SIS 144140, 4140-22 to SIS 144140, 4140-24 to SIS 144140
- UK:
5083 to BS 1470, 5083 to BS 1471, 5083 to BS 1472, 5083 to BS 1474
- USA:
5083, 5083 to AMS 4056, 5083 to AMS 4057, 5083 to AMS 4058, 5083 to AMS 4059, 5083 to ASTM B209M, 5083 to ASTM B210M, 5083 to ASTM B221M, 5083 to ASTM B241M, 5083 to ASTM B247M, 5083 to ASTM B345/B345M, 5083 to ASTM B547/B547M, 5083 to MIL DTL-45225F, 5083 to MIL DTL-46027J, 5083 to MIL DTL-46083D, 5083 to QQ A-200/4, 5083 to QQ A-250/6, 5083 to QQ A-367, 5183, ER5183 to AWS A5.10/A5.10M, R5183 to AWS A5.10/A5.10M, UNS A95083, UNS A95183
- Yugoslavia:
3.5354.00/AlMg4.5Mn to JUS C.C2.100
- Tradenames:
AIRCO 5183, ALCAN D54S, ALCAN WG-D 54 S, LNM ALMG 4,5 MN, LNM ALMG 4,5 MNZR, LNT ALMG 4,5 MN

Links

[ProcessUniverse](#)

[Producers](#)

[Reference](#)

[Shape](#)

Material Inventor

When designing the parts in Autodesk Inventor Professional 2022, a standard Aluminium 5083 material was chosen from the “Autodesk Material Library”. Parameters is seen in Figure 1 below.

Material Editor: Aluminum 5083 87 Cold Formed ×

Identity Appearance ↔ **Physical** ↔

▶ **Information**

▼ **Basic Thermal**

Thermal Conductivity	1.170E+02 W/(m·K)	▲ ▼
Specific Heat	0.900 J/(g·°C)	▲ ▼
Thermal Expansion Coefficient	26.000 μm/(m·°C)	▲ ▼

▼ **Mechanical**

Behavior	Isotropic	▼
Young's Modulus	69.000 GPa	▲ ▼
Poisson's Ratio	0.33	▲ ▼
Shear Modulus	25940.000 MPa	▲ ▼
Density	2.660 g/cm ³	▲ ▼

▼ **Strength**

Yield Strength	285.000 MPa	▲ ▼
Tensile Strength	385.000 MPa	▲ ▼

Thermally Treated

Figure 1 - Material properties Aluminium 5083, Inventor

ATTACHMENT B

Stress Analysis Results

Abbreviations used throughout this document:

- fp = Bin fitment palte
- bp = Baseplate

For all analysis', the stress analysis process is shown with figures in this order:

1. Area extrusions (preparations before analysis)
2. Added force
3. Added constraints
4. Generated mesh
5. Results Von Mises stress
6. Results Displacement

The results are presented by shapes, starting with X-shape, continuing with H-shape, and ending with O-shape.

X-shape fp

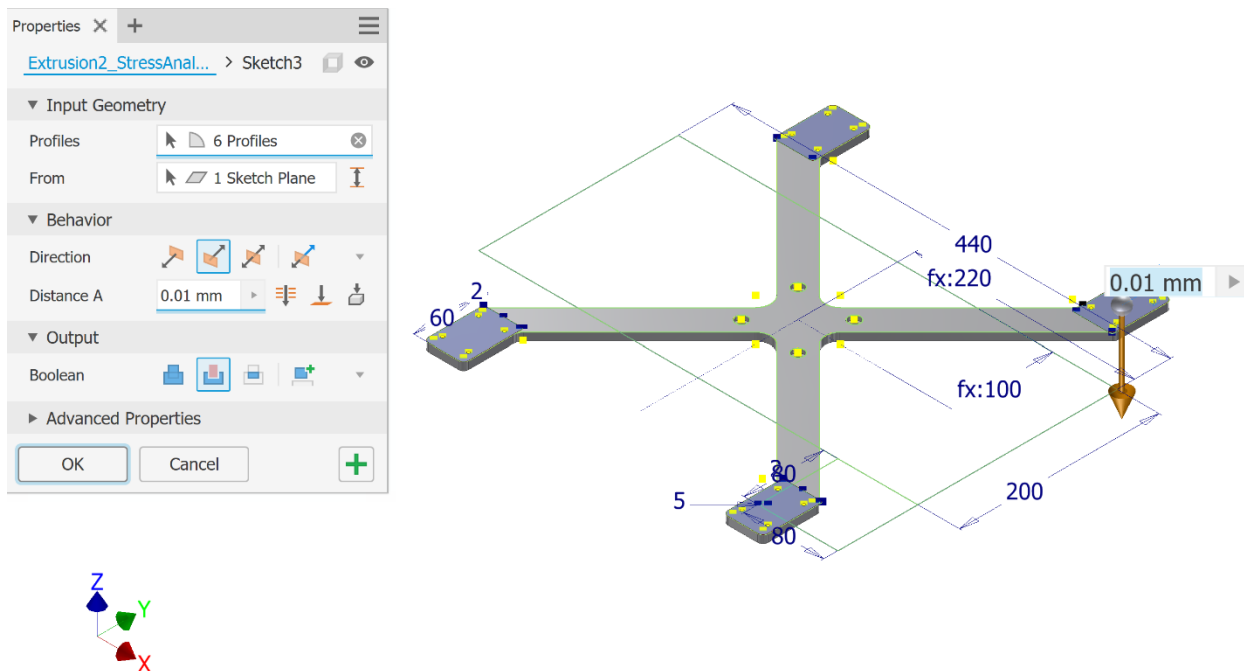

Figure 1 - X-shape fp, area extrusion of brackets (coloured blue, direction shown by orange arrow)

ATTACHMENT B

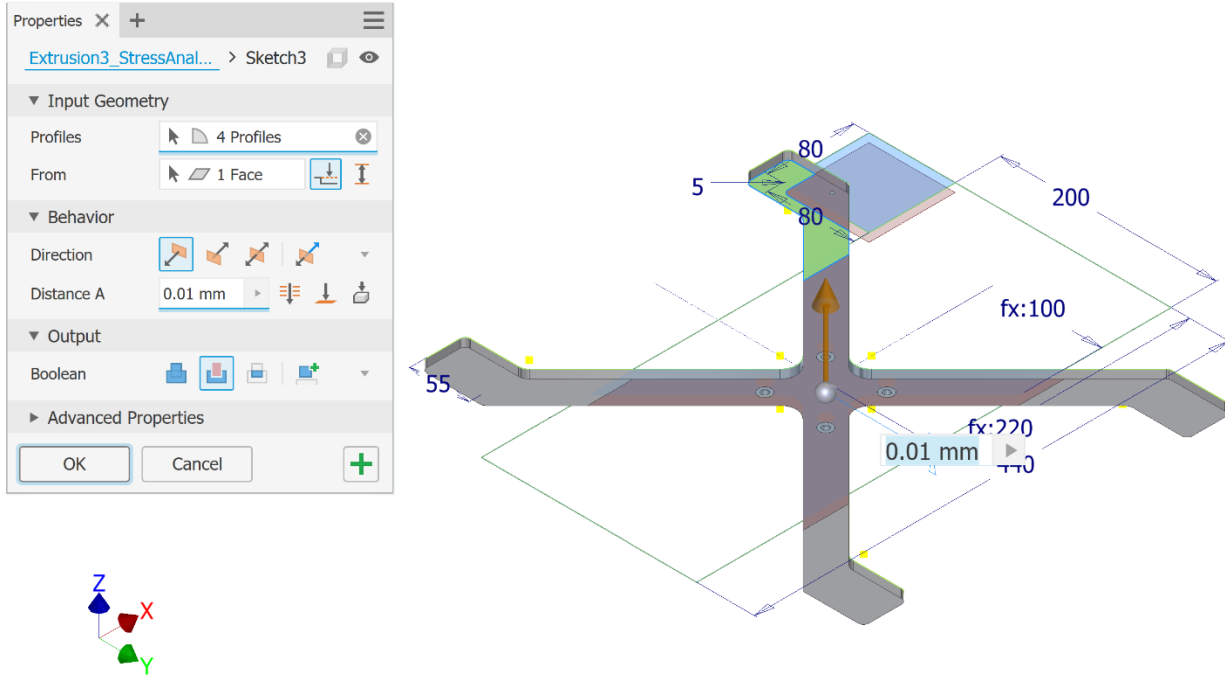

Figure 2 - X-shape fp, area extrusion of bp (coloured red, direction shown by orange arrow)

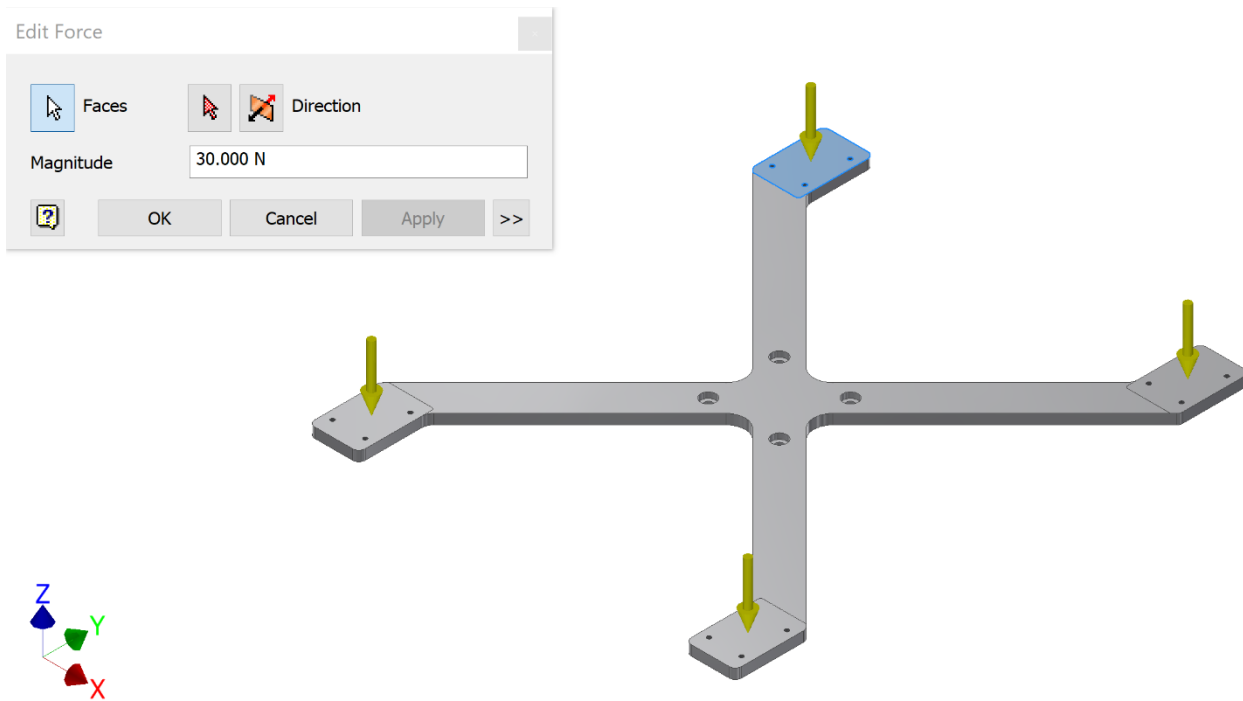

Figure 3 - X-shape fp, added force in one corner (blue area with yellow directional arrow). This is done for all corners, four in total.

ATTACHMENT B

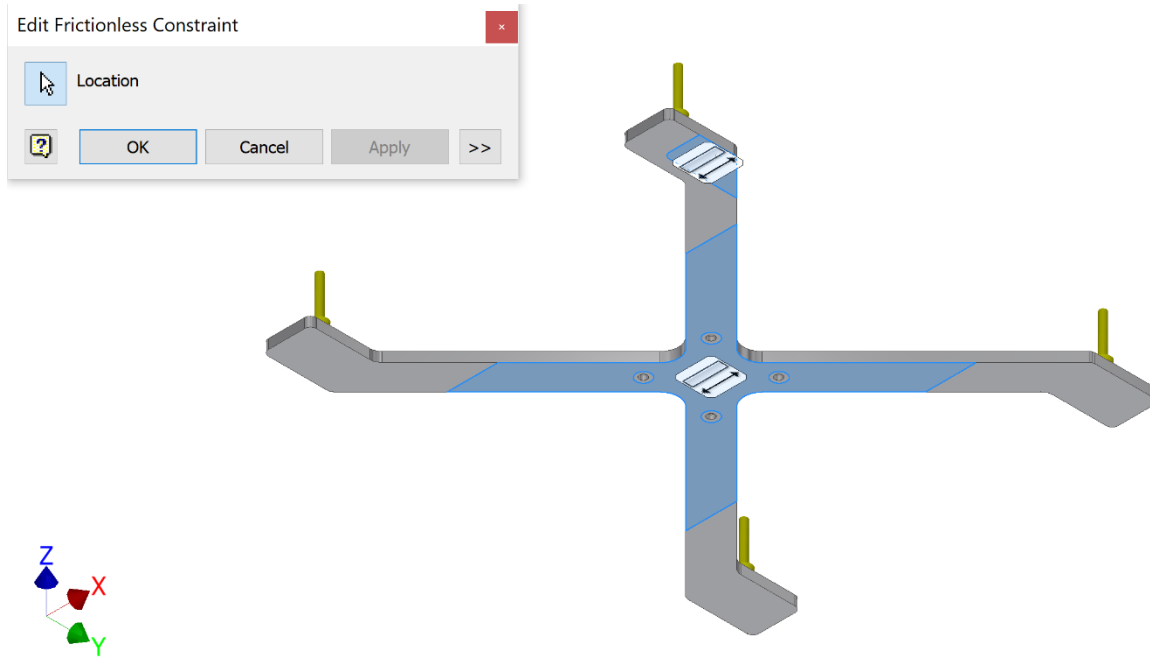

Figure 4 - X-shape fp, added frictionless constraints* (coloured blue)

*Frictionless constraints are constraints that prevents movement or deforming in normal directions relative to the surface. The surface is free to move in tangential direction.

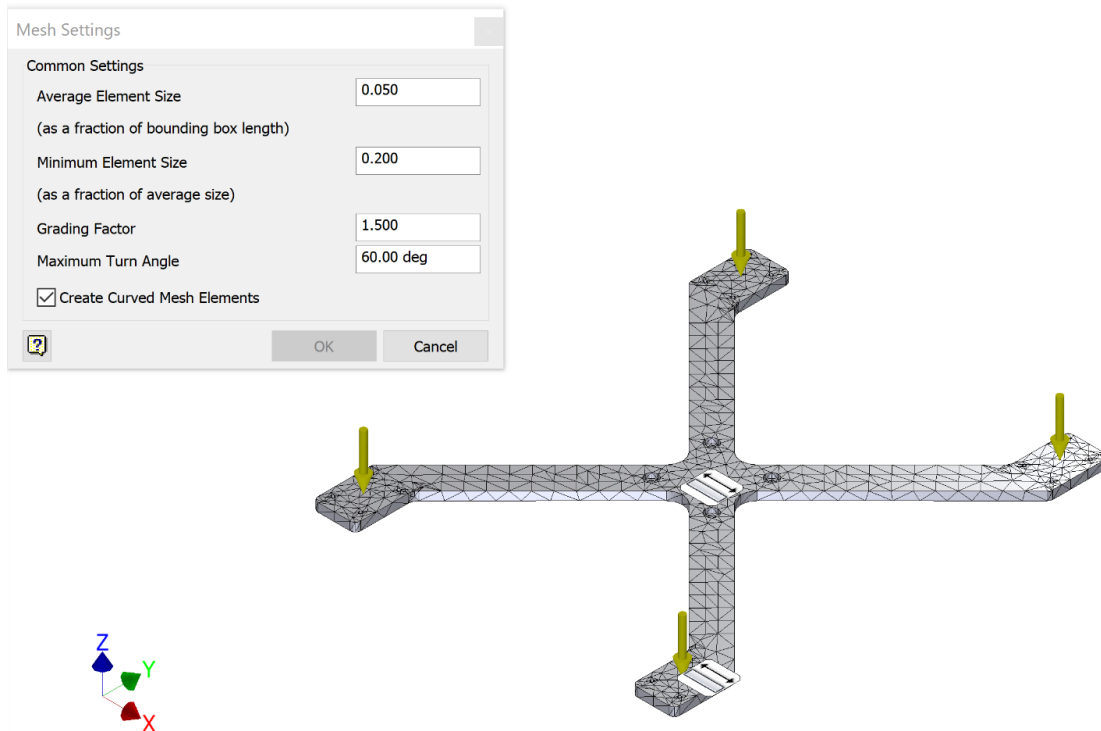

Figure 5 - X-shape fp, generated mesh with element size 0.05.

ATTACHMENT B

Nodes:9081
Elements:4482
Type: Von Mises Stress
Unit: MPa
5/22/2023, 8:23:20 PM

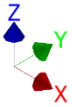
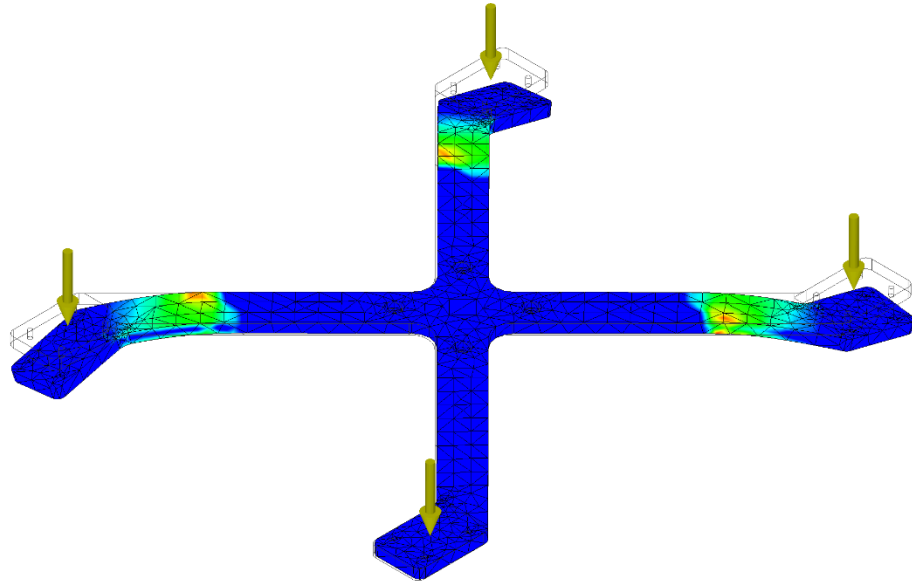
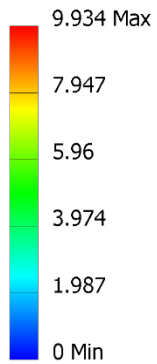

Figure 6 - X-shape fp, results Von Mises stress

Nodes:9081
Elements:4482
Type: Displacement
Unit: mm
5/22/2023, 8:24:22 PM

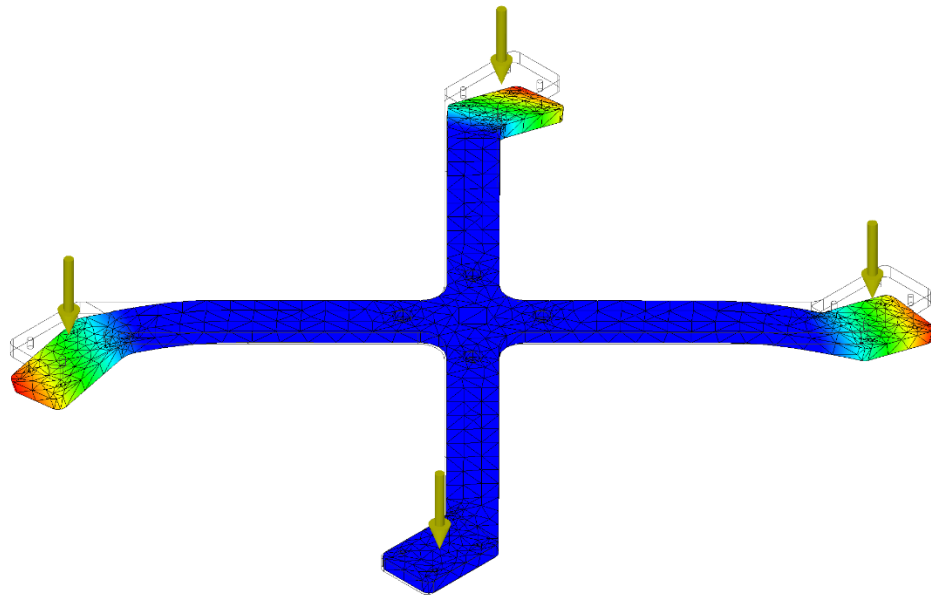
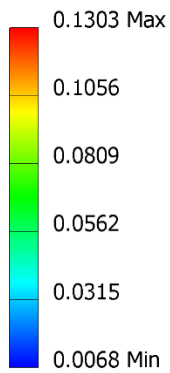

Figure 7 - X-shape fp, results displacement

ATTACHMENT B

X-shape bp

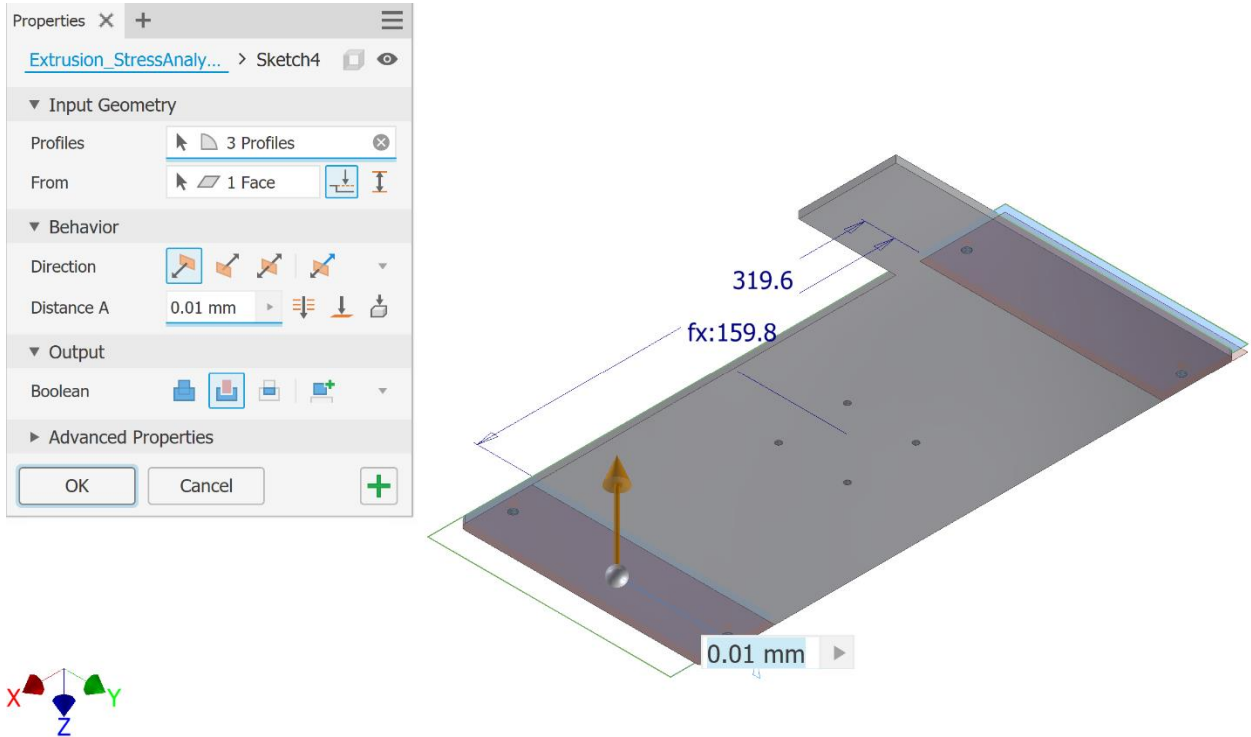

Figure 8 - X-shape bp, area extrusion of lift modules (coloured red, direction shown by orange arrow)

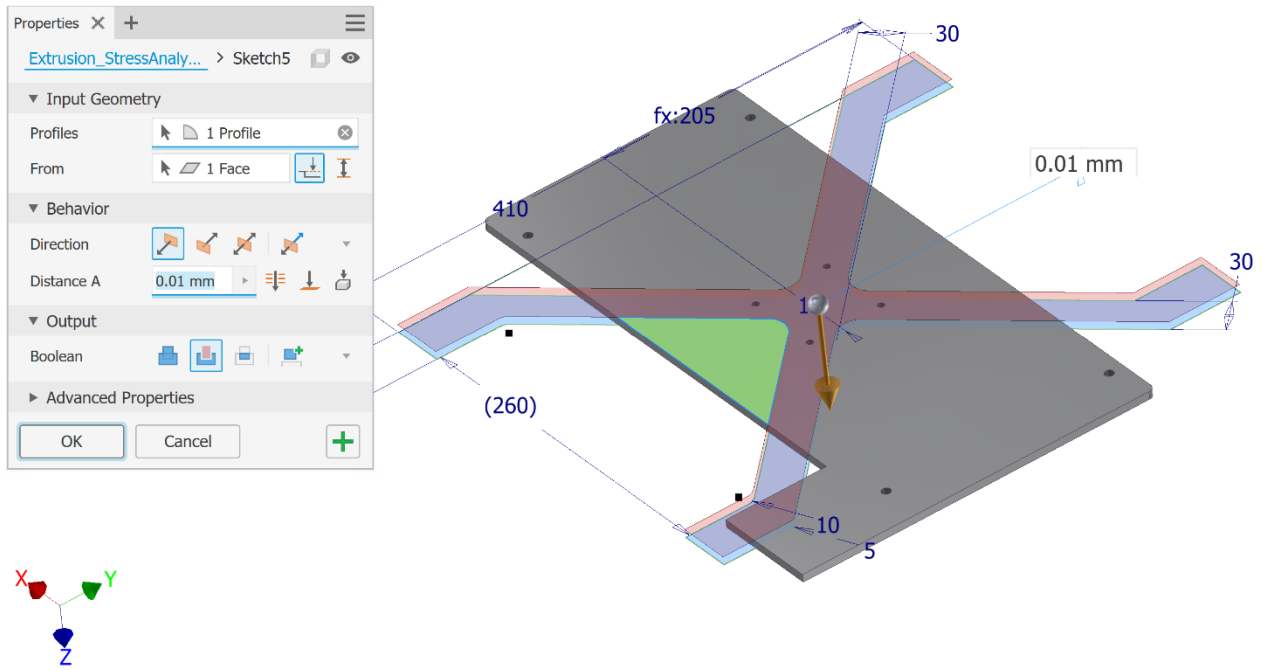

Figure 9 - X-shape bp, area extrusion of X-shape (coloured red, direction shown by orange arrow)

ATTACHMENT B

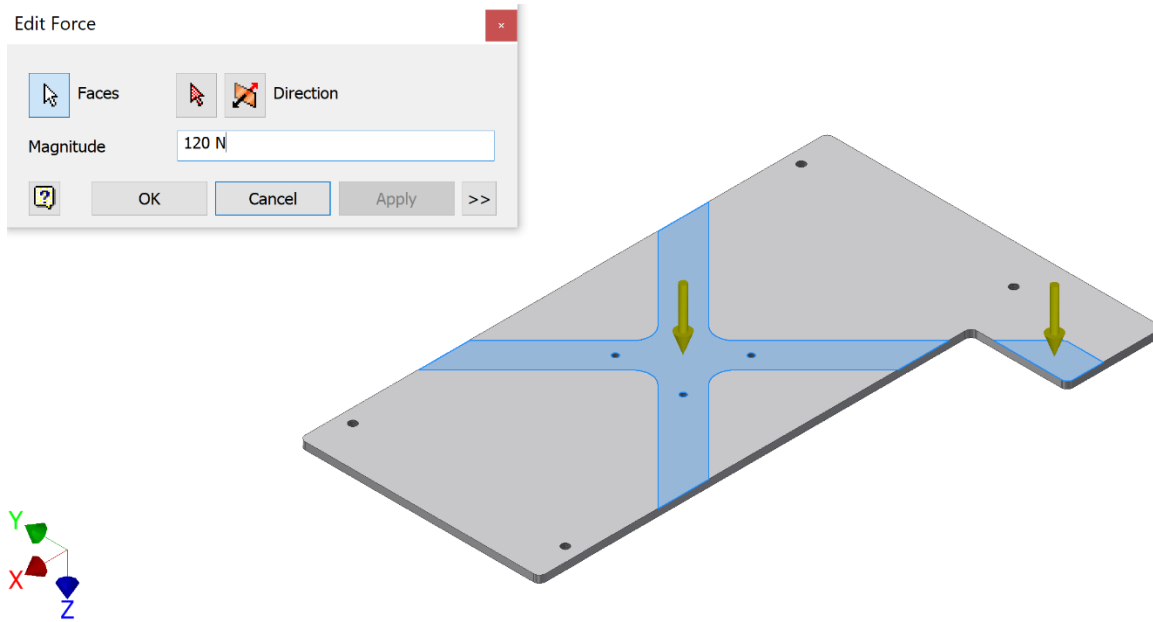

Figure 10 - X-shape bp, added force (blue areas with yellow directional arrows)

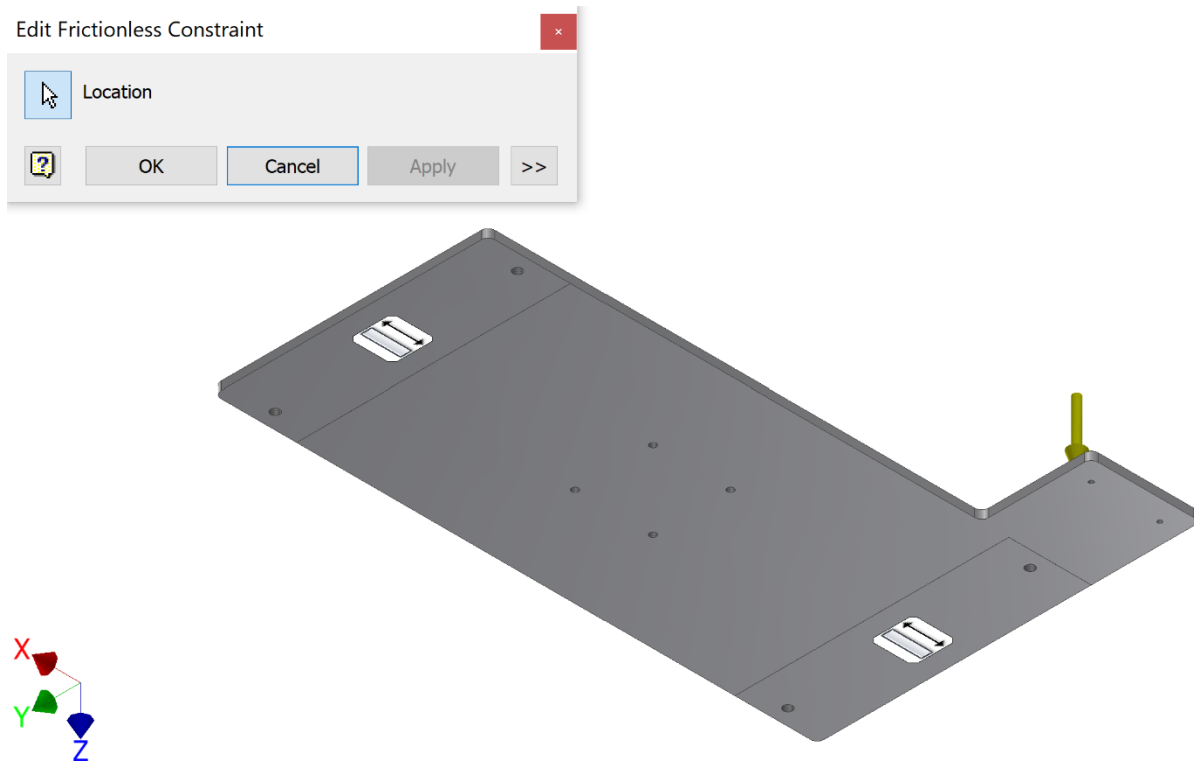

Figure 11 - X-shape bp, added frictionless constraints (specified areas where the symbols are)

ATTACHMENT B

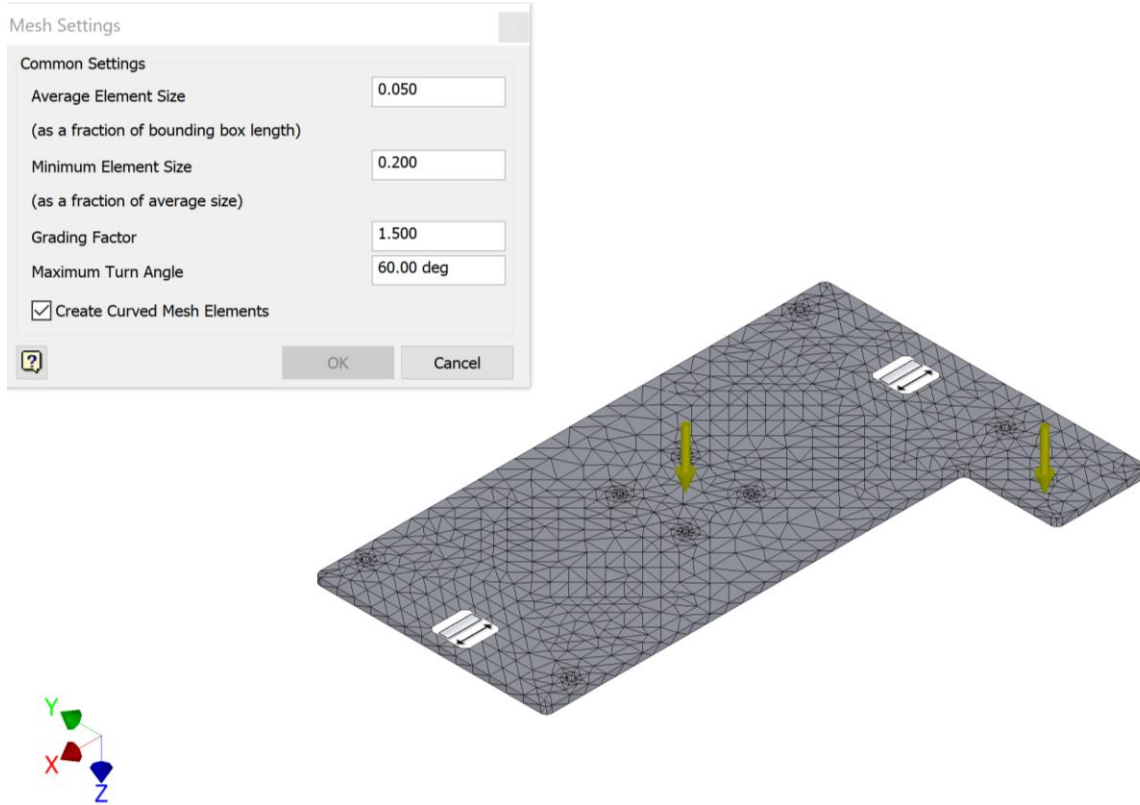

Figure 12 - X-shape bp, generated mesh with element size 0.05

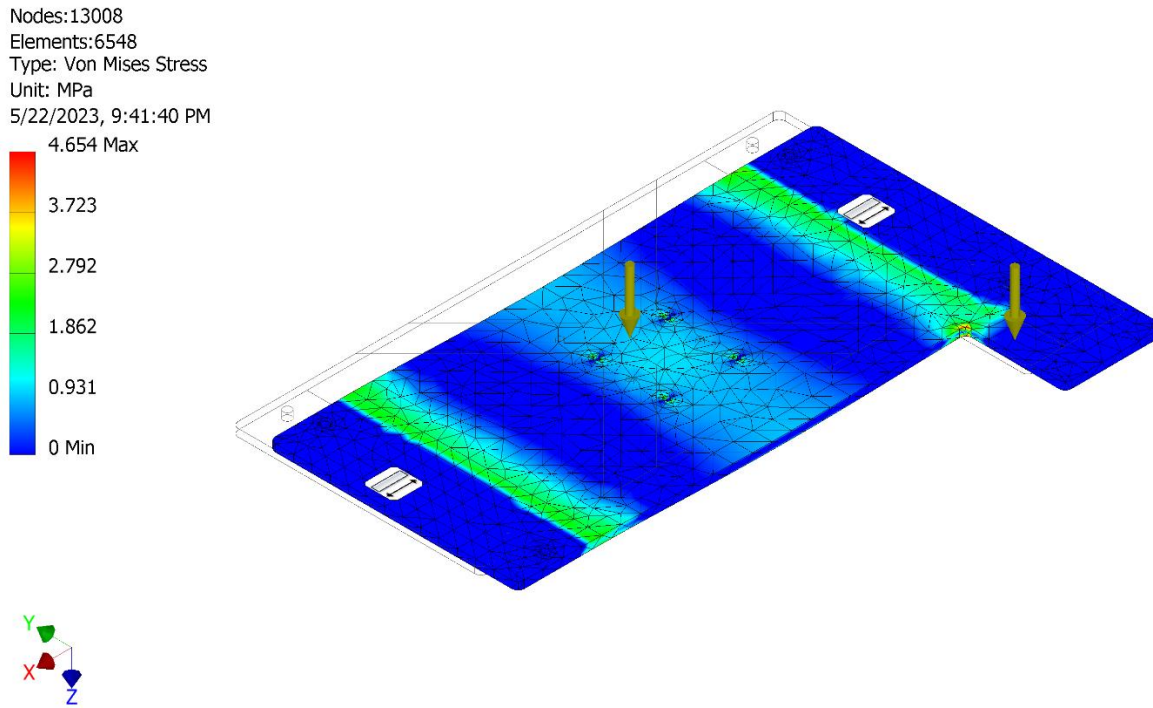

Figure 13 - X-shape bp, results Von Mises stress

ATTACHMENT B

Nodes:13008
Elements:6548
Type: Displacement
Unit: mm
5/22/2023, 9:42:22 PM

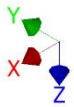
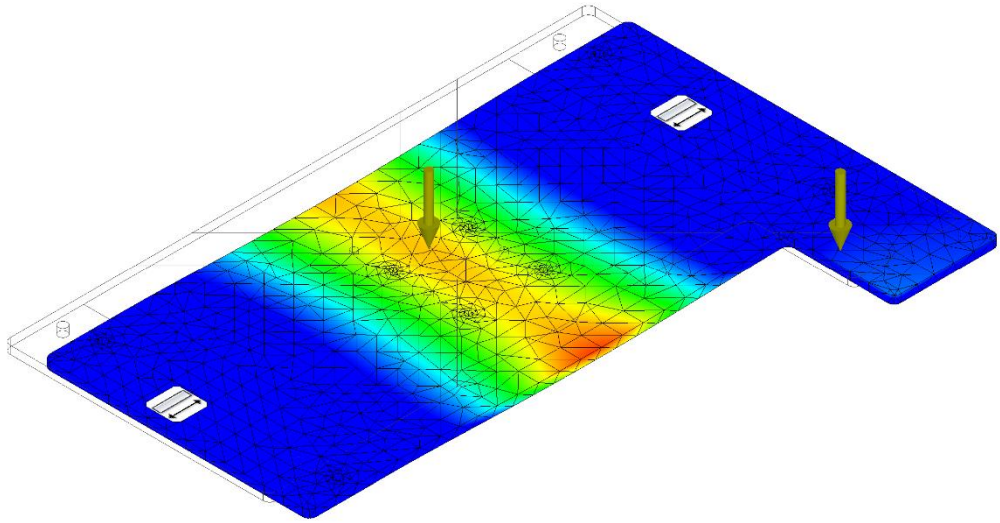
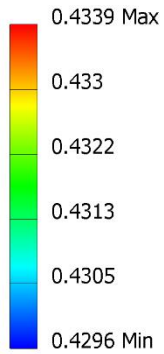

Figure 14 - X-shape bp, results displacement

H-shape fp

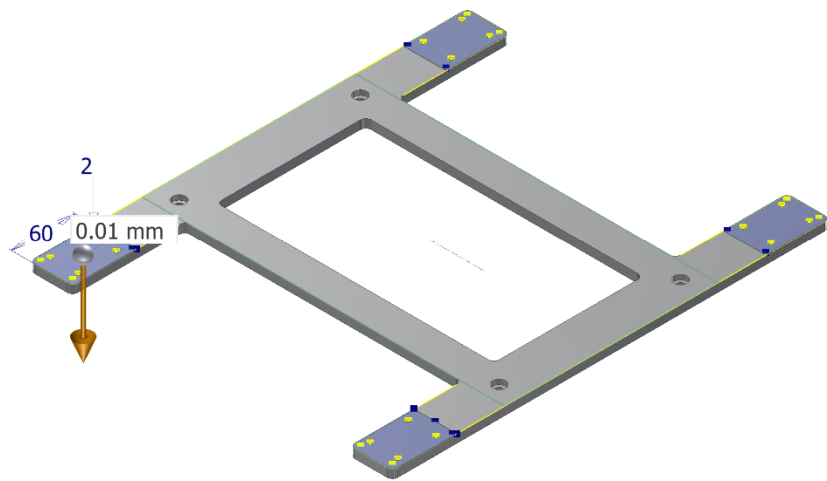
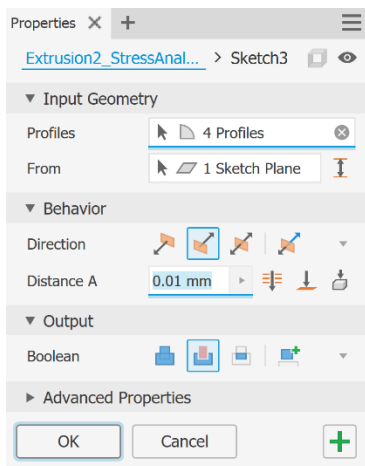

Figure 15 - H-shape fp, area extrusion of brackets (coloured blue, direction shown by orange arrow)

ATTACHMENT B

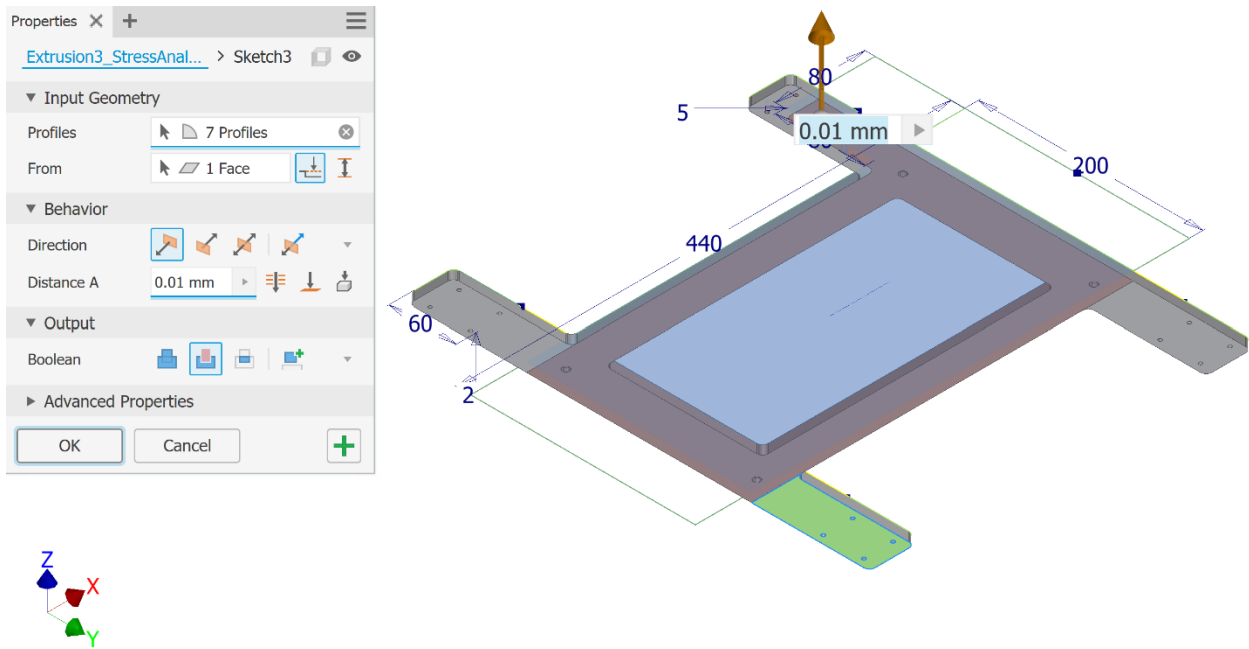

Figure 16 - H-shape fp, area extrusion of bp (coloured red, direction shown by orange arrow)

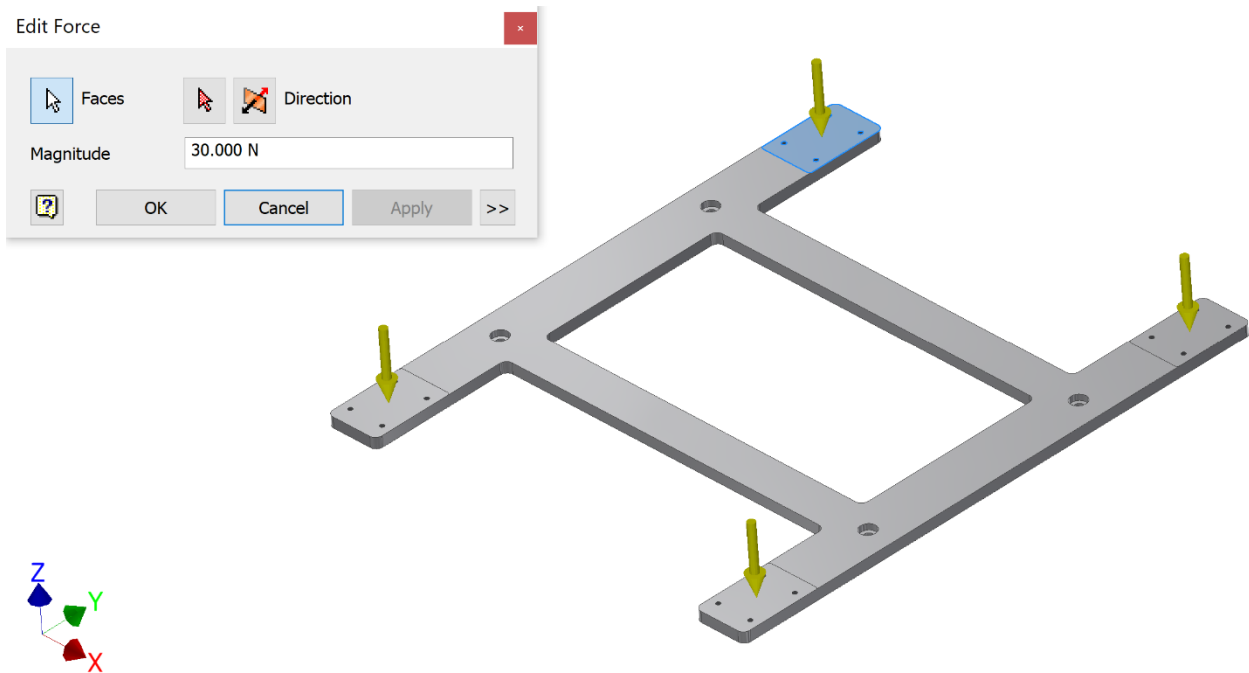

Figure 17 - H-shape fp, added force in one corner (blue area with yellow directional arrow). This is done for all corners, four in total.

ATTACHMENT B

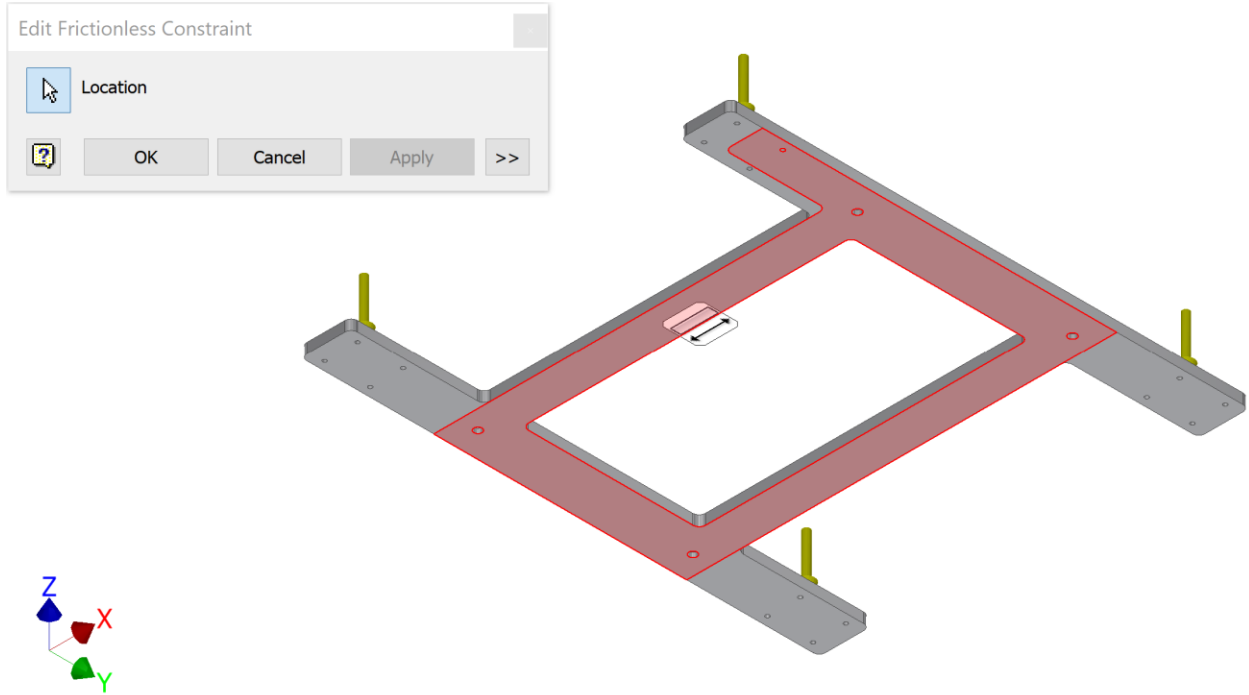

Figure 18 - H-shape fp, added frictionless constraints (coloured red)

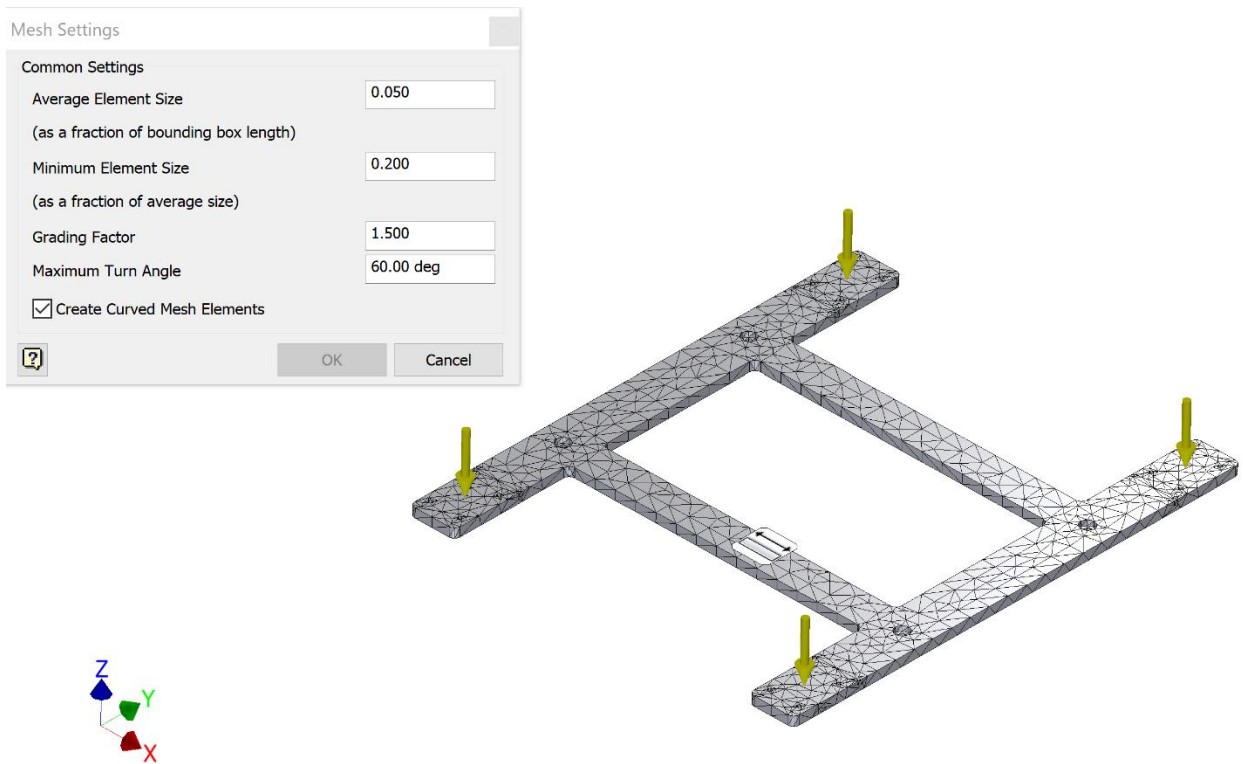

Figure 19 - H-shape fp, generated mesh with element size 0.05

ATTACHMENT B

Nodes:11558
Elements:5666
Type: Von Mises Stress
Unit: MPa
5/22/2023, 9:01:36 PM

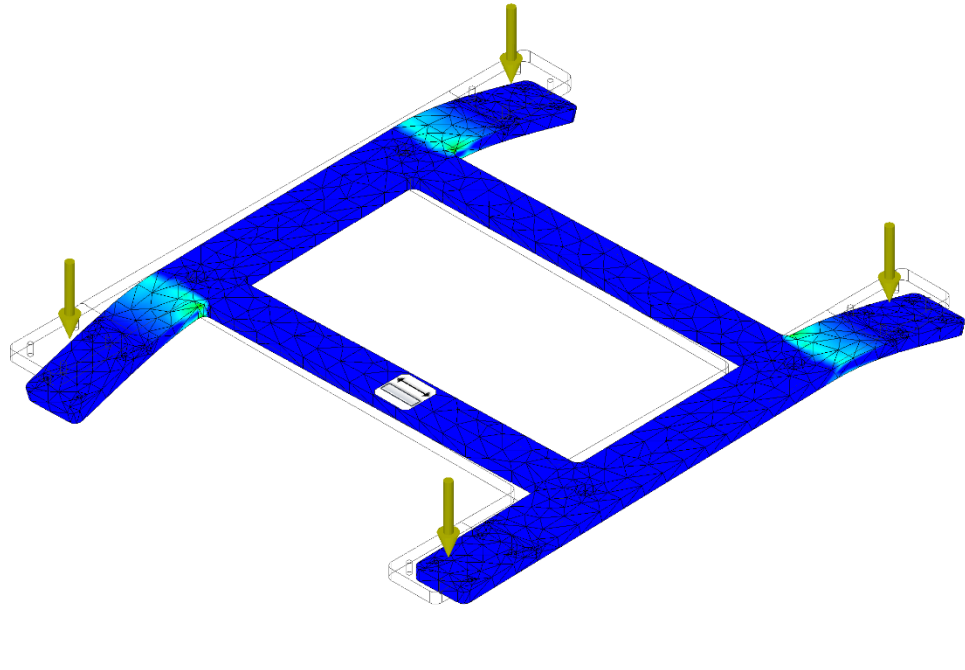
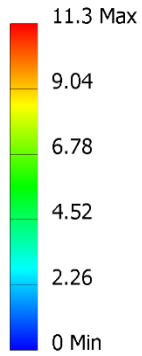

Figure 20 - H-shape fp, results Von Mises stress

Nodes:11558
Elements:5666
Type: Displacement
Unit: mm
5/22/2023, 9:02:52 PM

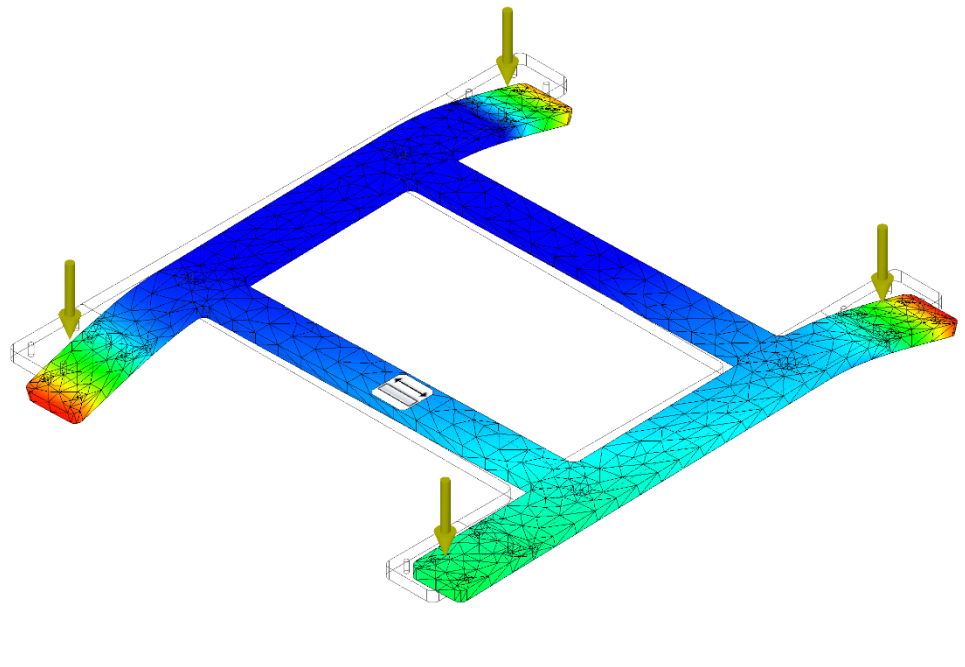
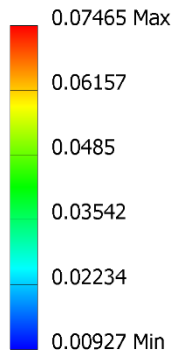

Figure 21 - H-shape fp, results displacement

ATTACHMENT B

H-shape bp

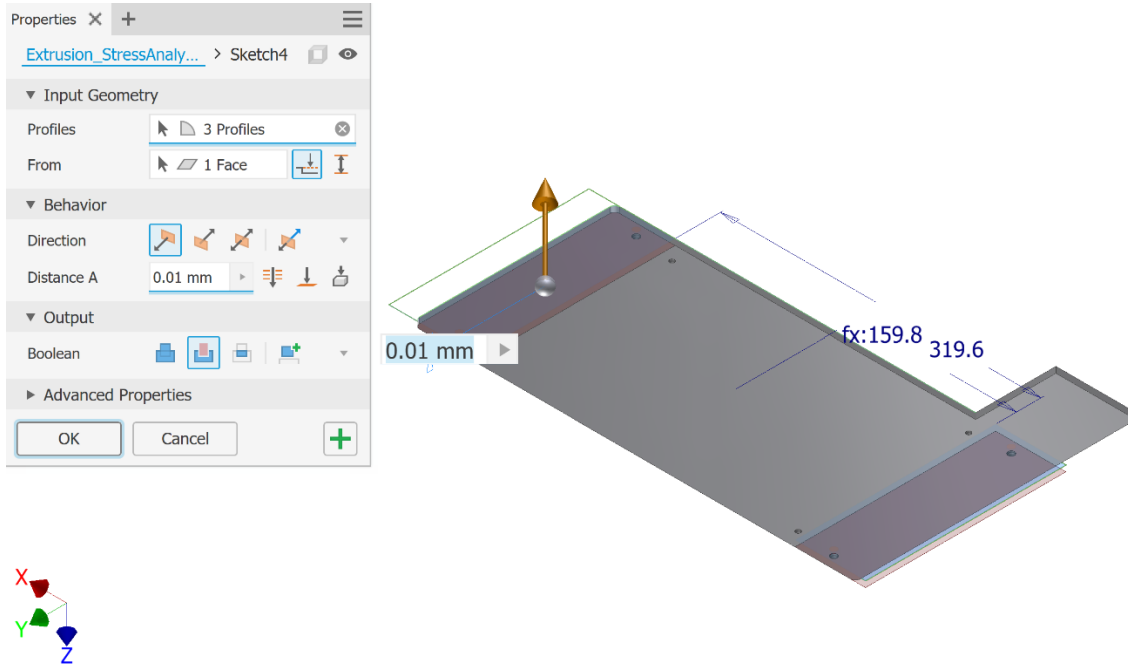

Figure 22 - H- & 0-shape bp, area extrusion of lift modules* (coloured red, direction shown by orange arrow)

*0-shape on bp for area extrusion of lift modules are similar as for H-shape and will therefore not be shown in respective chapter (Chapter “0-shape bp”).

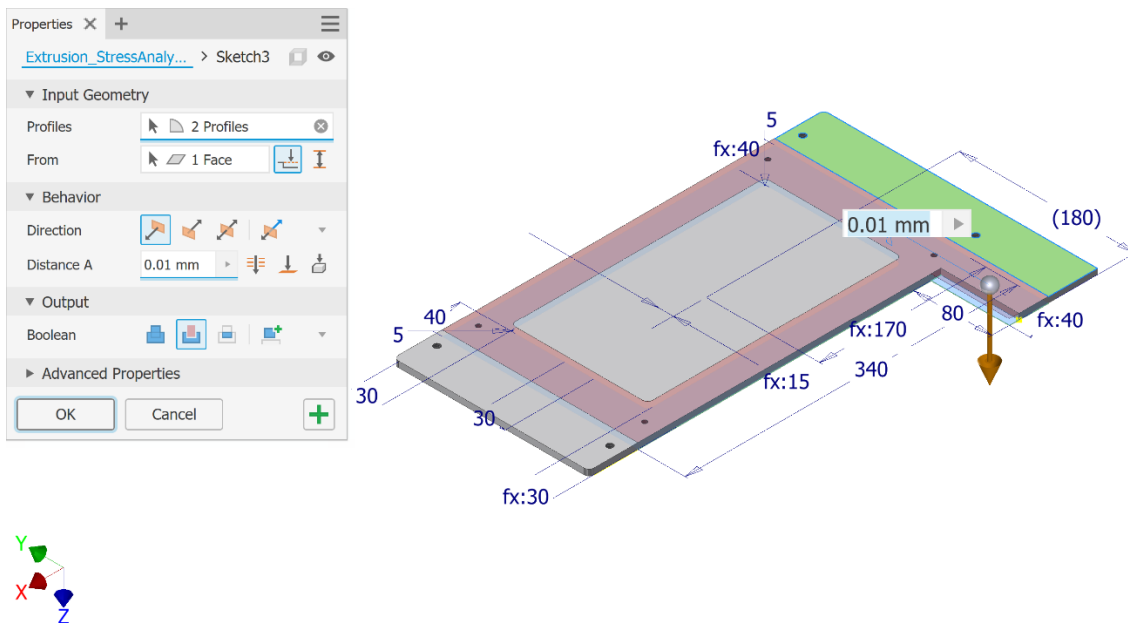

Figure 23 - H-shape bp, area extrusion of fp (coloured red, direction shown by orange arrow)

ATTACHMENT B

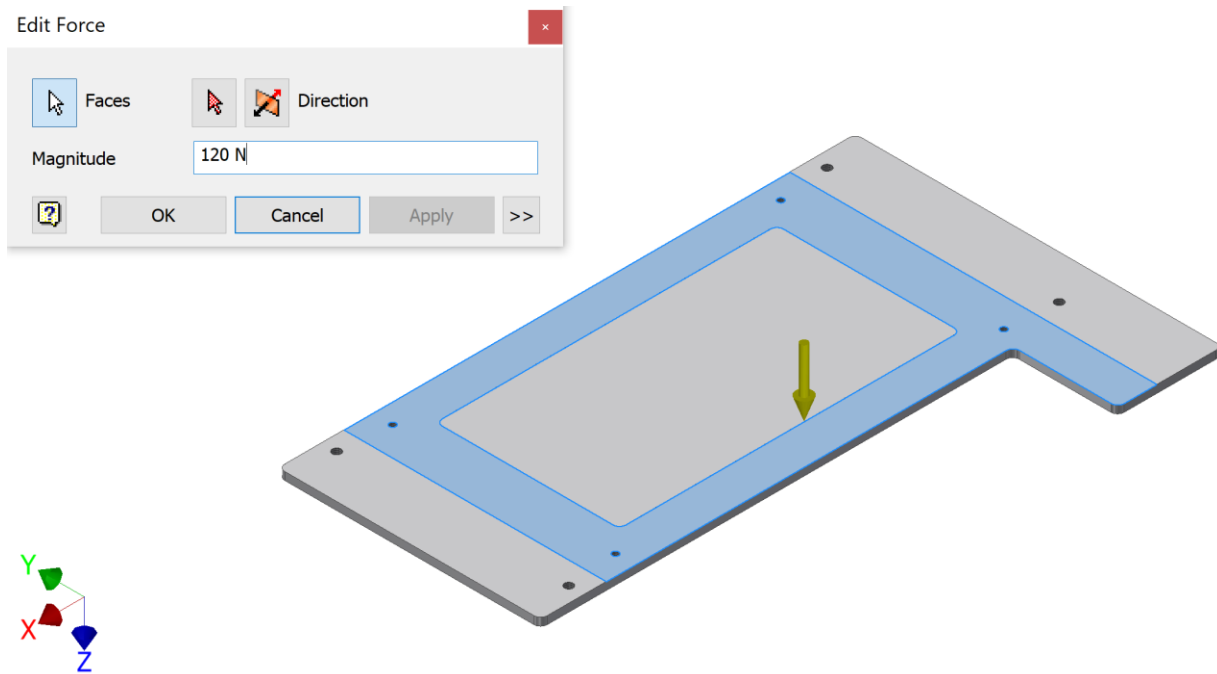

Figure 24 - H-shape bp, added force (blue area with yellow directional arrow)

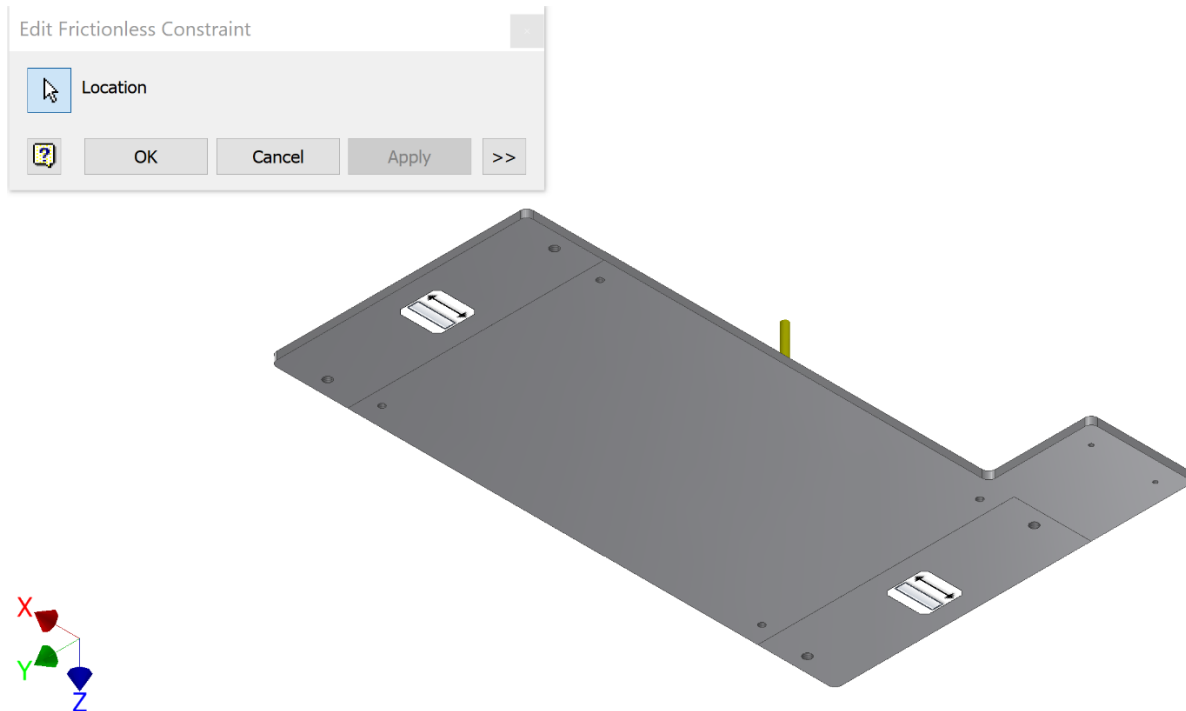

Figure 25 - H- & 0-shape bp, added constraints** (specified areas where the symbols are)

**0-shape on bp for added constraints are similar as for H-shape and will therefore not be shown in respective chapter (Chapter “0-shape bp”).

ATTACHMENT B



Figure 26 - H-shape bp, generated mesh with element size 0.05

Nodes:11705
Elements:5724
Type: Von Mises Stress
Unit: MPa
5/22/2023, 9:52:18 PM
3.204 Max
2.563
1.923
1.282
0.641
0 Min

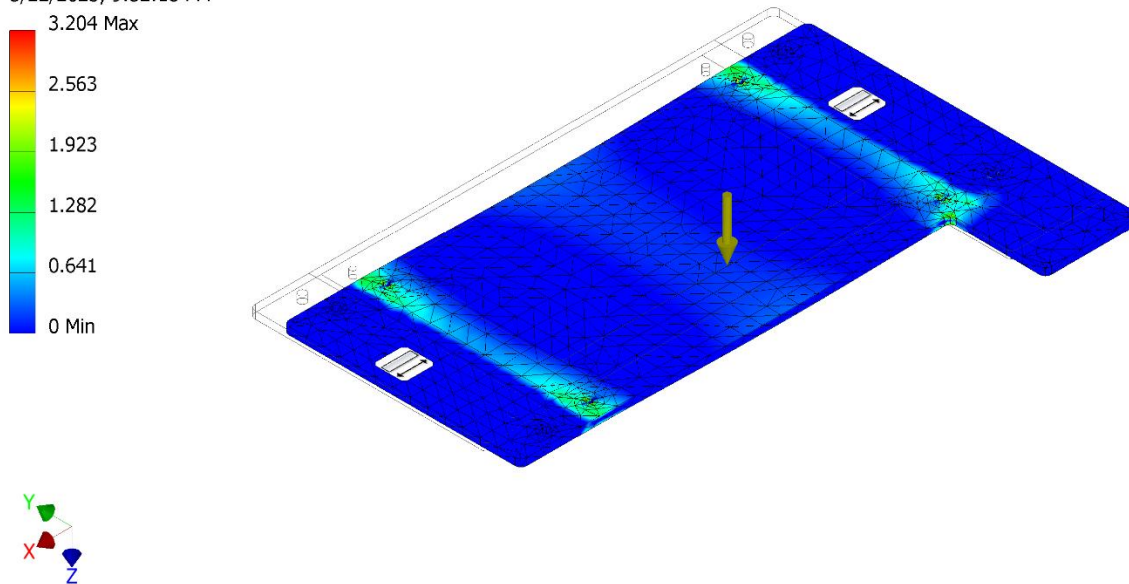

Figure 27 - H-shape bp, results Von Mises stress

ATTACHMENT B

Nodes:11705
Elements:5724
Type: Displacement
Unit: mm
5/22/2023, 9:53:00 PM

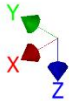
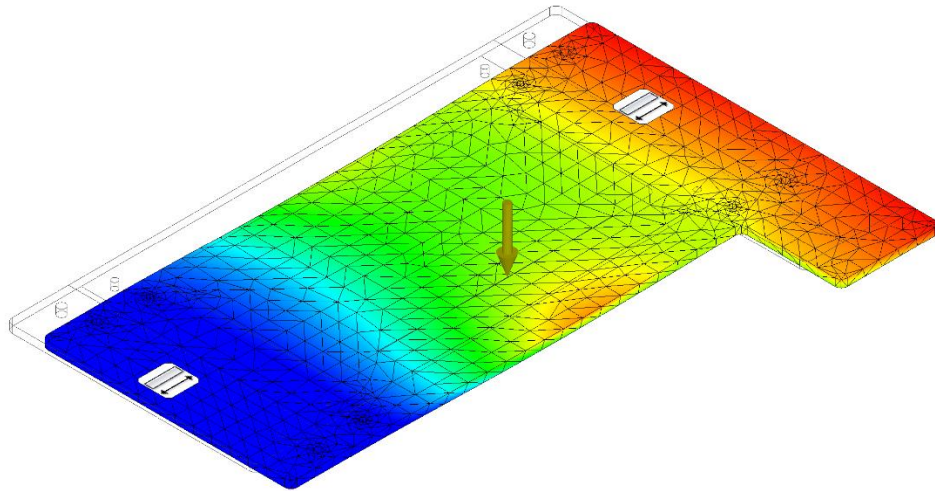
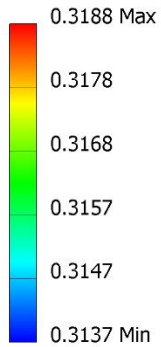

Figure 28 - H-shape bp, results displacement

0-shape fp

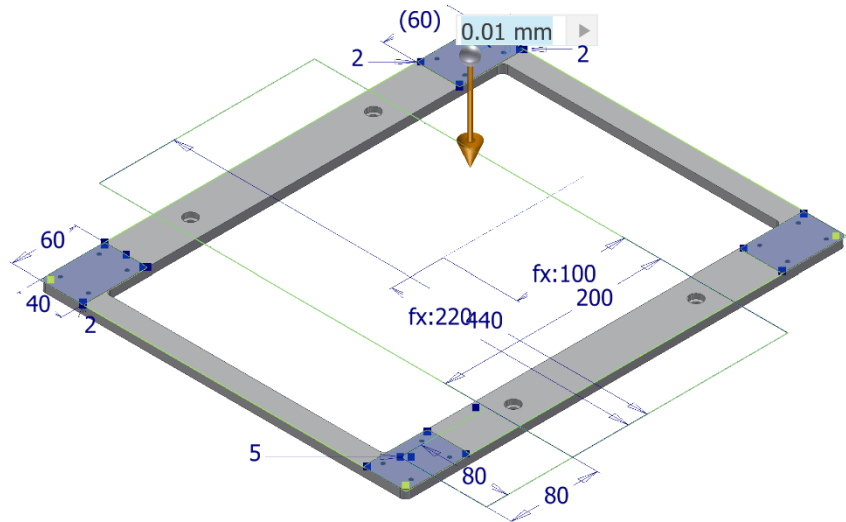
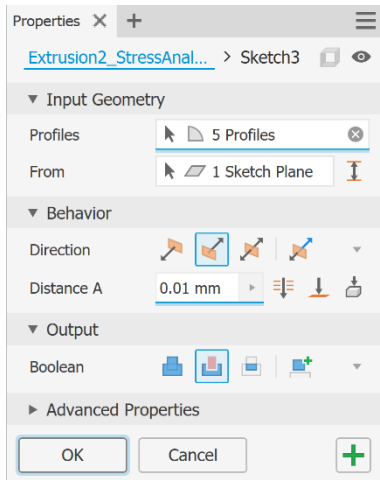

Figure 29 - 0-shape fp, area extrusion of brackets (coloured blue, direction shown by orange arrow)

ATTACHMENT B

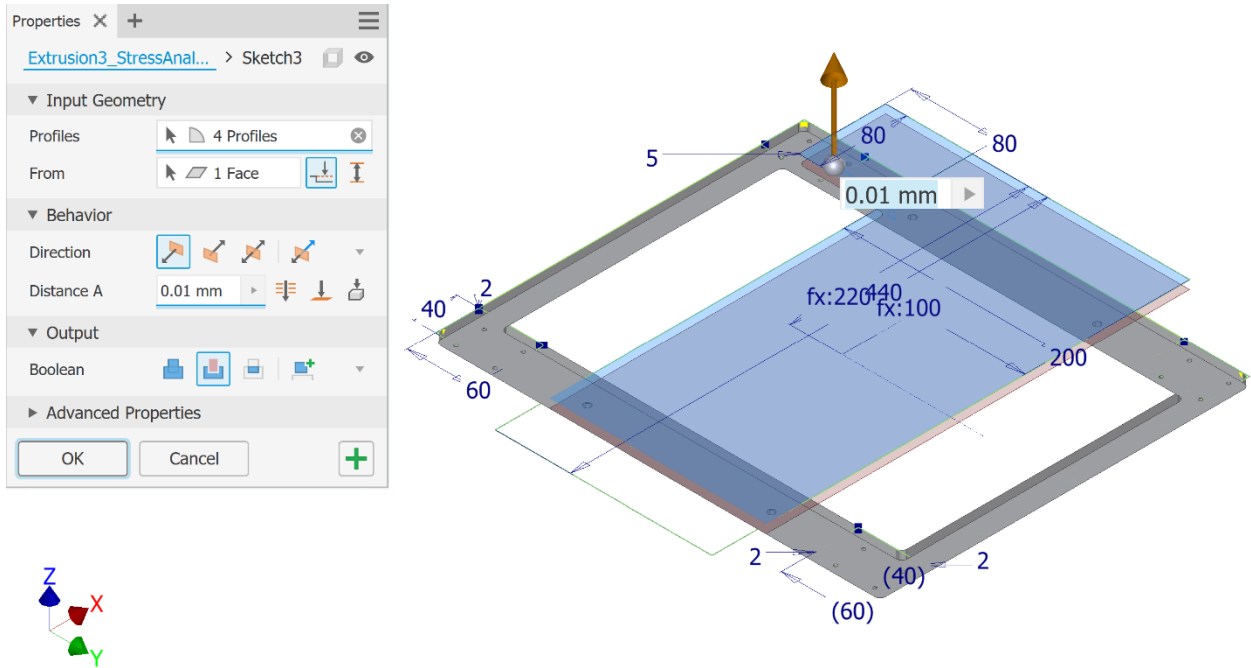

Figure 30 - 0-shape fp, area extrusion of bp (coloured blue, direction shown by orange arrow)

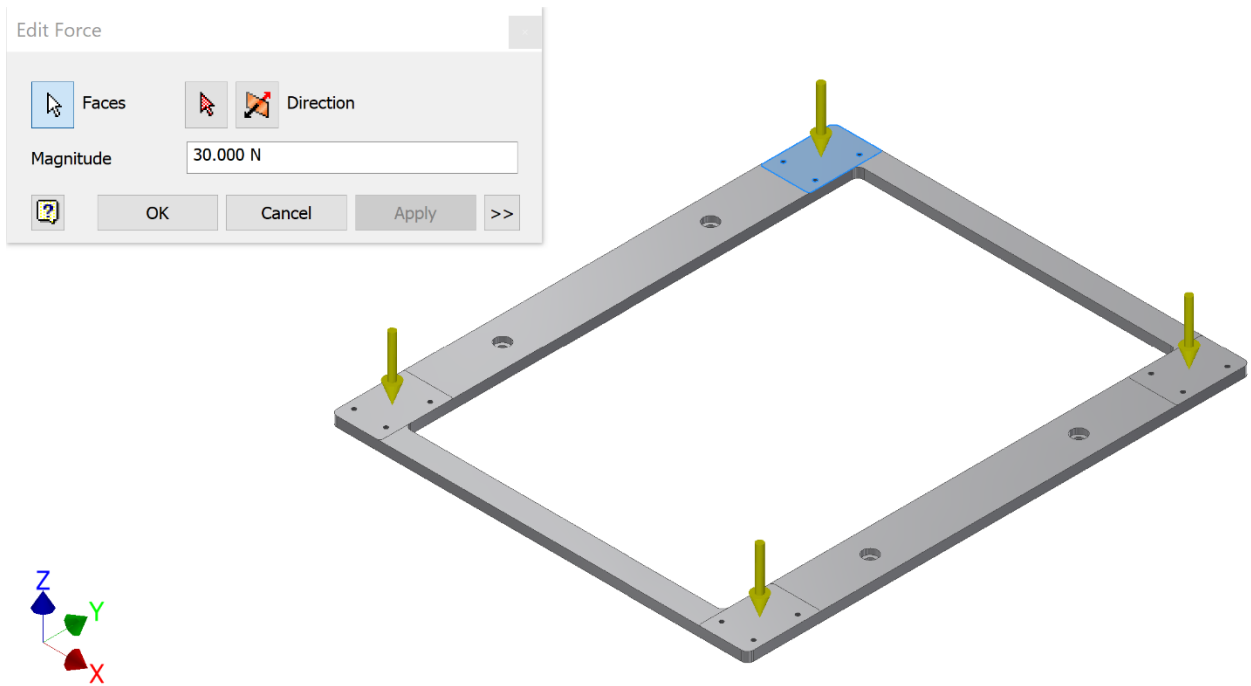

Figure 31 - 0-shape fp, added force in one corner (blue area with yellow directional arrow). This is done for all corners, four in total.

ATTACHMENT B

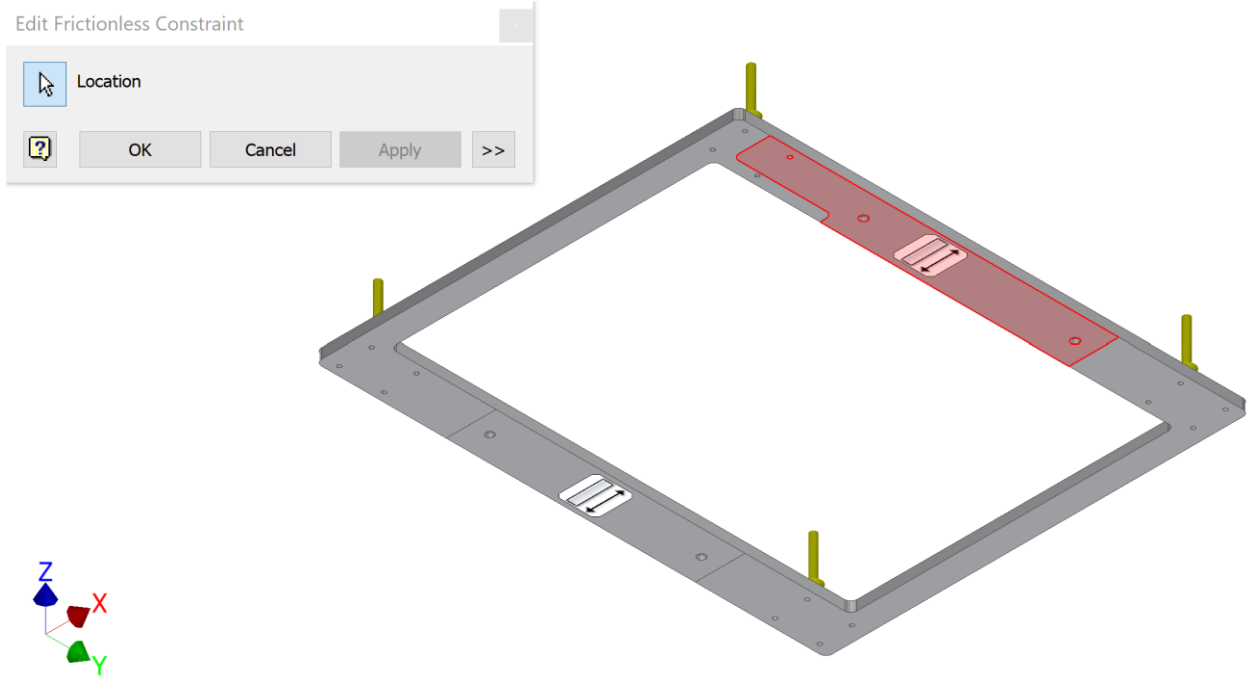

Figure 32 - 0-shape fp, added constraints (specified areas where the symbols are, one area coloured red)

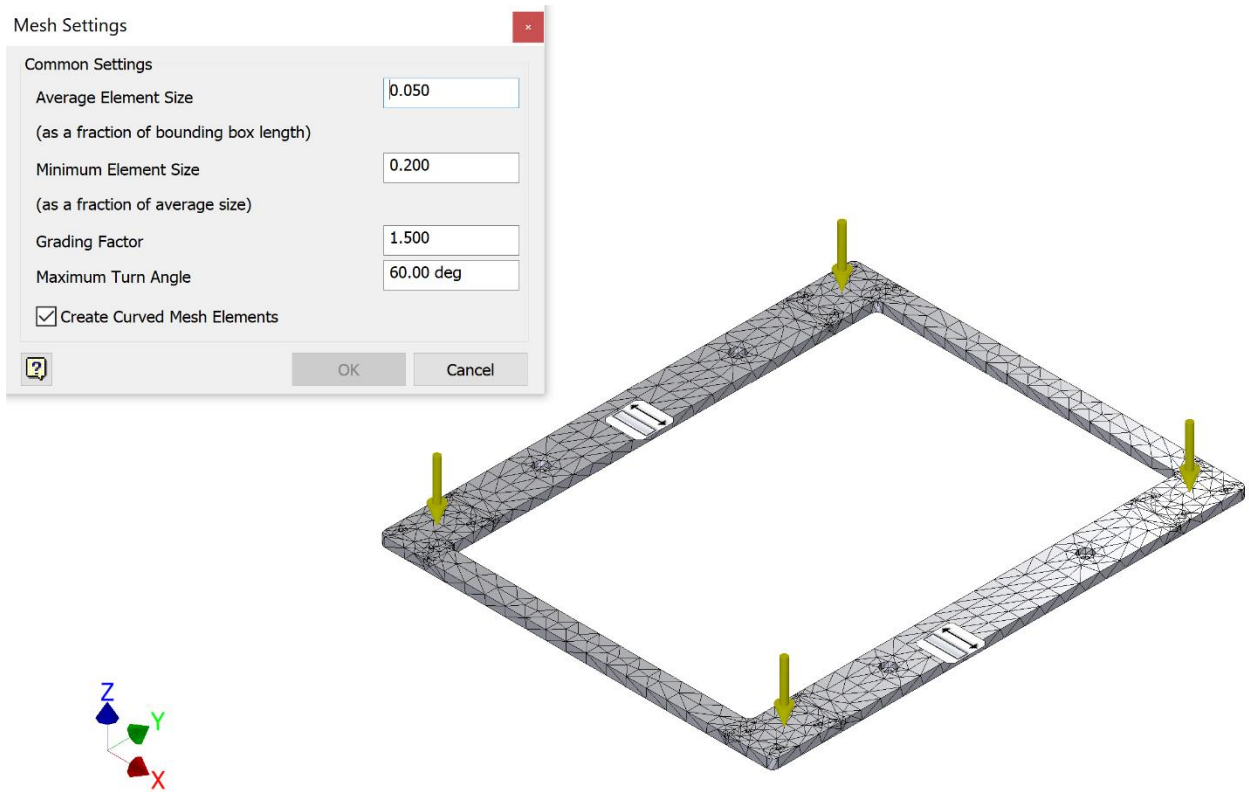

Figure 33 - 0-shape fp, generated mesh with element size 0.05

ATTACHMENT B

Nodes:11248
Elements:5508
Type: Von Mises Stress
Unit: MPa
5/22/2023, 9:06:30 PM

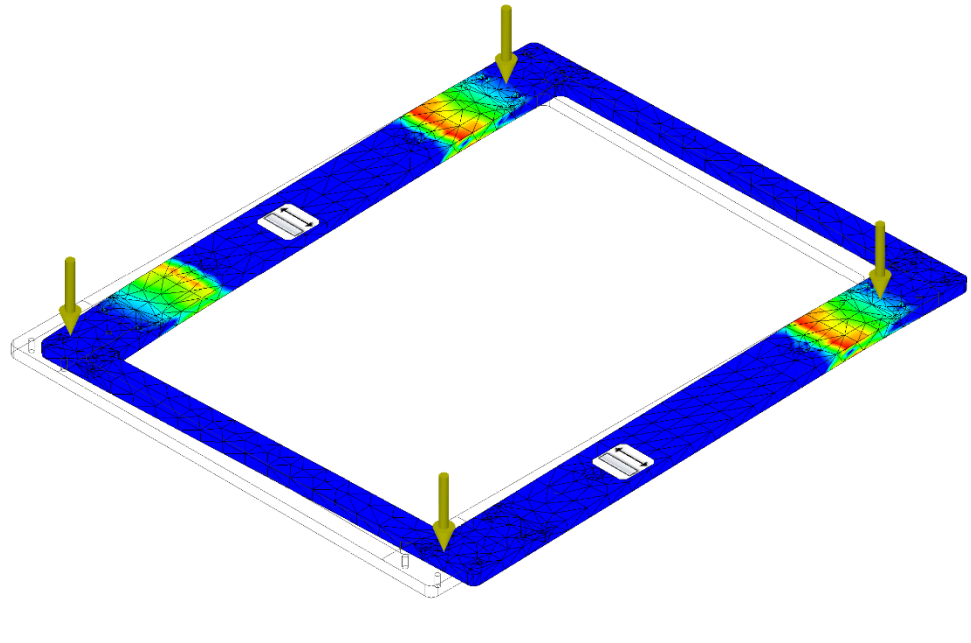
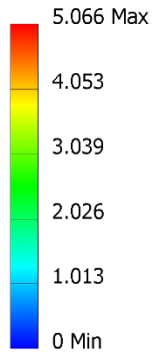

Figure 34 - 0-shape fp, results Von Mises stress

Nodes:11248
Elements:5508
Type: Displacement
Unit: mm
5/22/2023, 9:07:14 PM

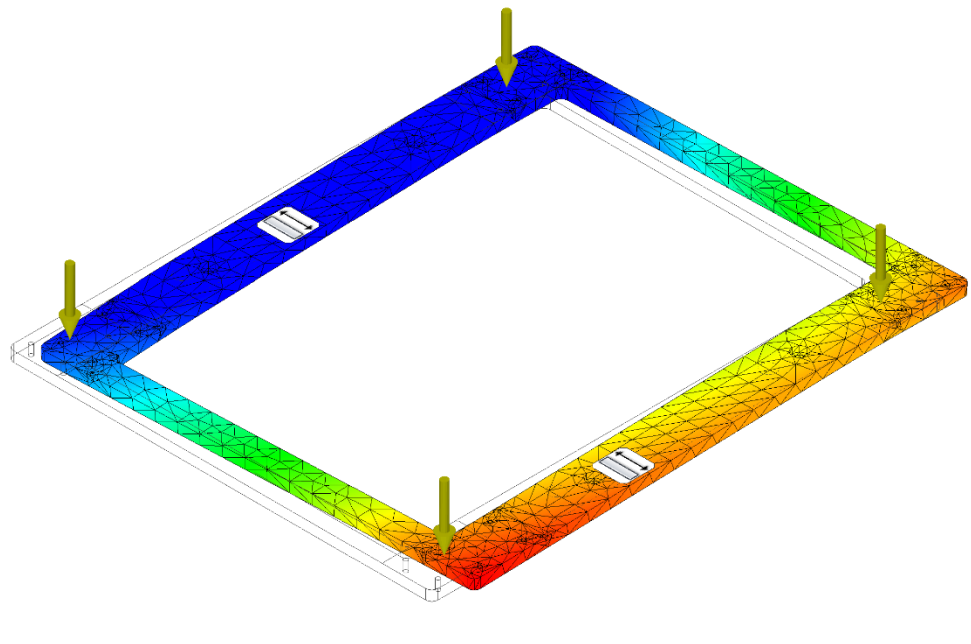
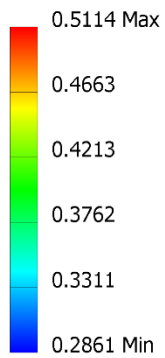

Figure 35 - 0-shape fp, results displacement

ATTACHMENT B

0-shape bp

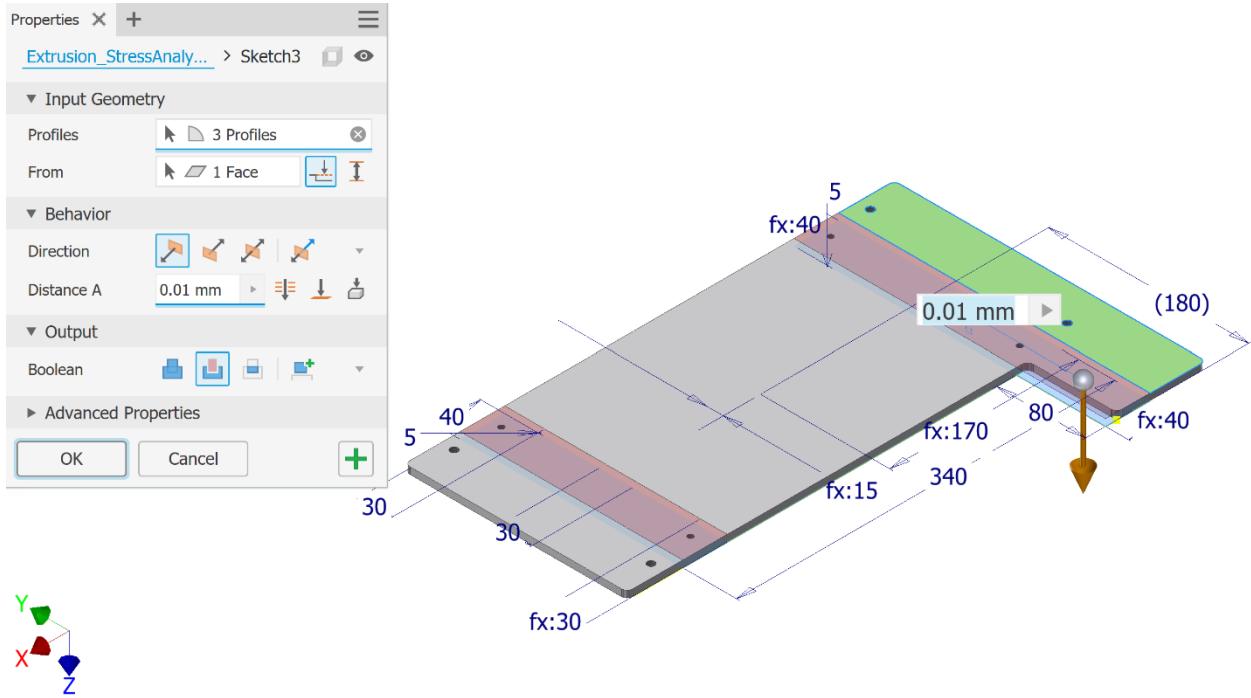

Figure 36 - 0-shape bp, area extrusion of fp (coloured red, direction shown by orange arrow)

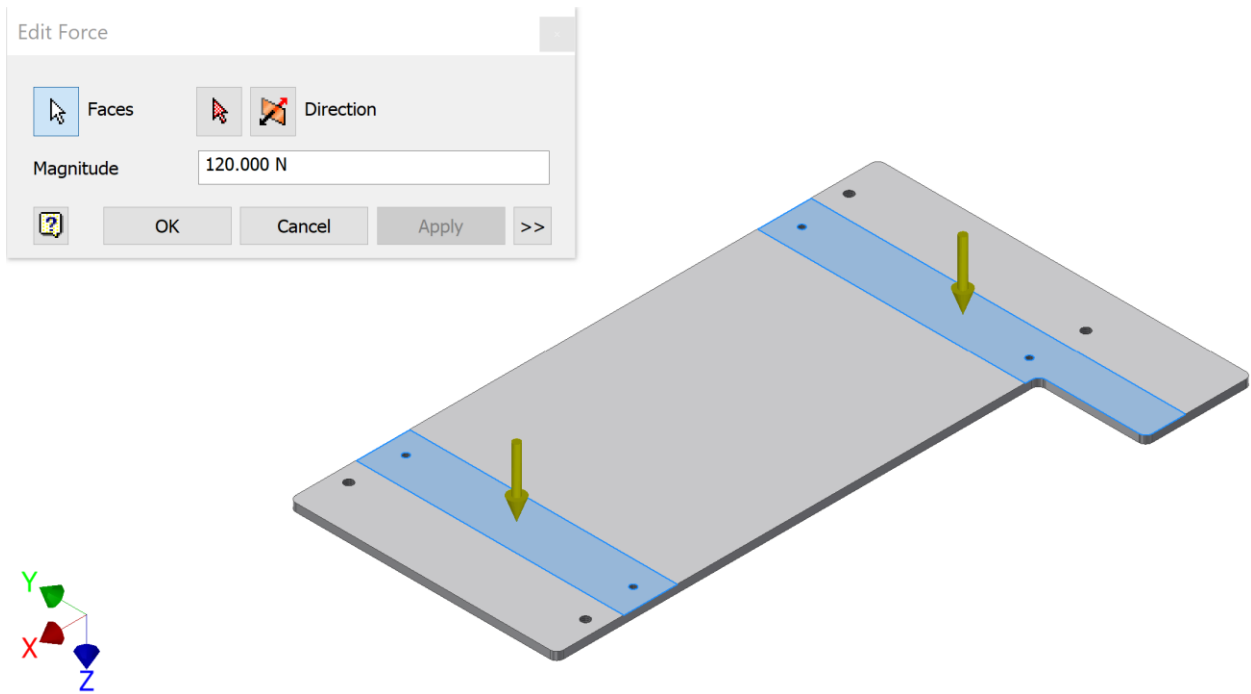

Figure 37 - 0-shape bp, added force (blue areas with yellow directional arrows)

ATTACHMENT B

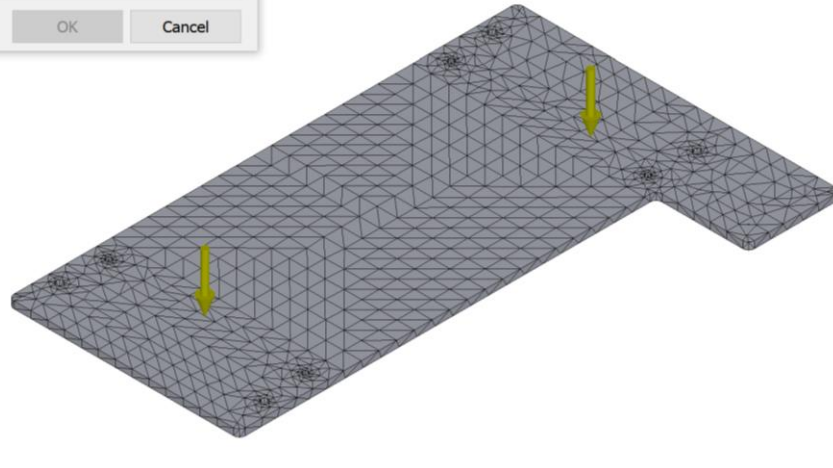
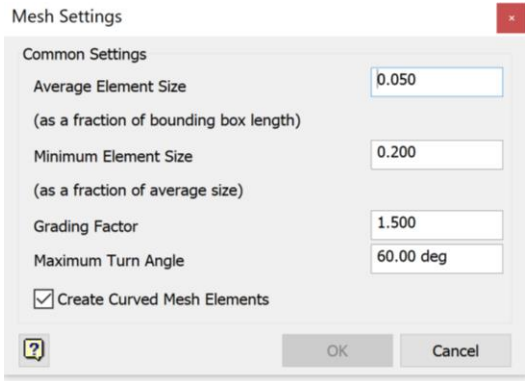

Figure 38 - 0-shape bp, generated mesh with element size 0.05

Nodes: 11468
Elements: 5668
Type: Von Mises Stress
Unit: MPa
5/22/2023, 9:59:03 PM

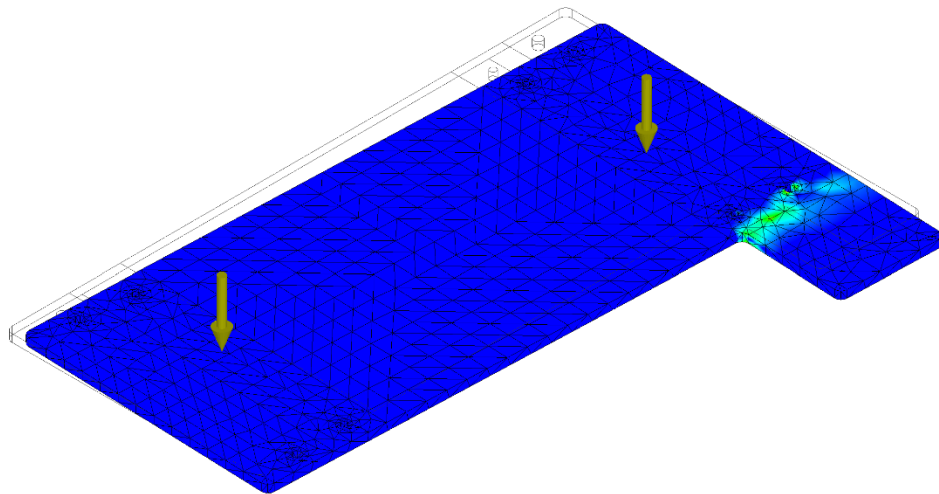
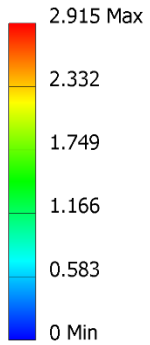

Figure 39 - 0-shape bp, results Von Mises stress

ATTACHMENT B

Nodes:11468
 Elements:5668
 Type: Displacement
 Unit: mm
 5/22/2023, 9:59:46 PM

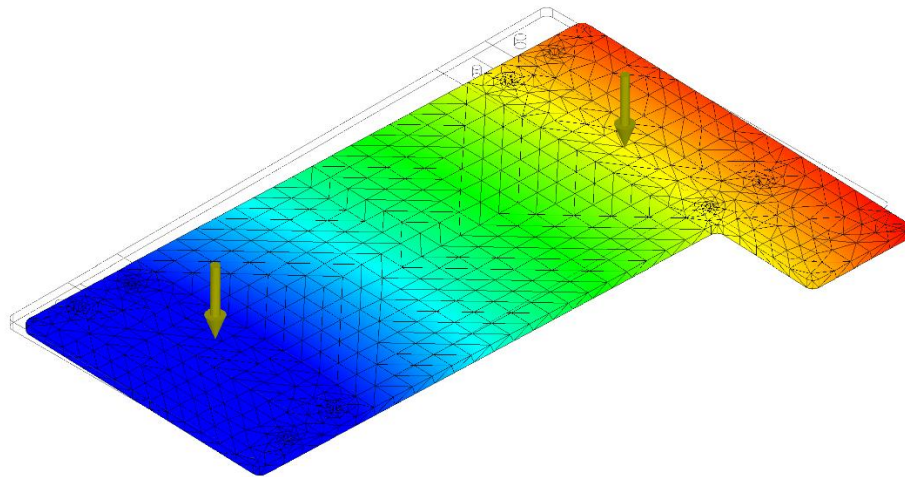
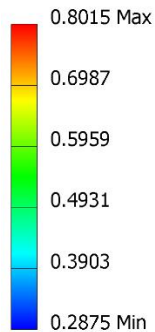

Figure 40 - 0-shape bp, results displacement

Results Summarize

Results are summarized in Table 1 below.

Table 1 - Results stress analysis

		X-shape	H-shape	0-shape
Bin fitment plate	Von Mises stress	9.934 MPa	11.3 MPa	5.066 MPa
	Displacement	0.1303 mm	0.07465 mm	0.5114 mm
Baseplate	Von Mises stress	4.654 MPa	3.204 MPa	2.915 MPa
	Displacement	0.4339 mm	0.3188 mm	0.8015 mm

The H-shaped Bin fitment plate is the only Bin fitment plate within the requirements. The corresponding Baseplate has the lowest value of displacement, however, it is out of specifications. The H-shape will anyhow be the best shape to proceed with. A new set of stress analysis with refined mesh have been performed for the H-shaped scenarios to verify the results, see Chapter “Redefined Mesh”.

ATTACHMENT B

Refining the Mesh

The chosen shape for the Bin fitment plate and the baseplate have been re-meshed to verify the previous stress analysis results. The extrusions, forces and constraints remain the same. There have been performed two iterations of the mesh element size, see the results in subchapters below.

Bin Fitment Plate

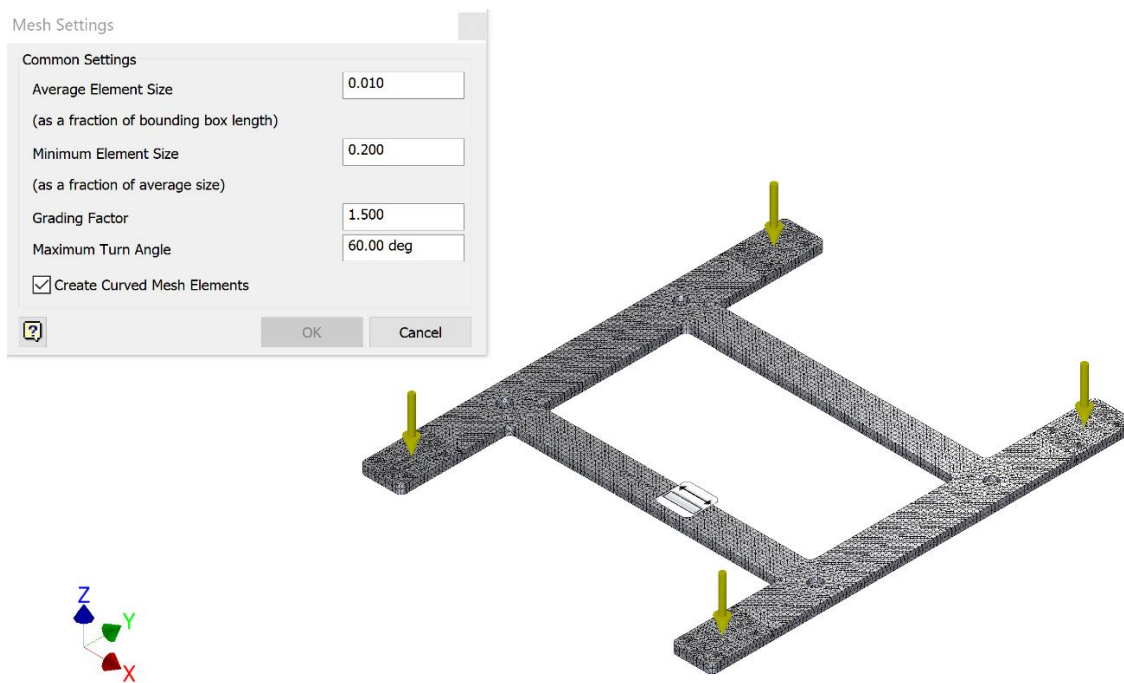

Figure 41 - H-shape fp refined mesh 0.01, generated mesh with element size 0.01

ATTACHMENT B

Nodes:136967
Elements:84927
Type: Von Mises Stress
Unit: MPa
5/24/2023, 9:03:56 PM

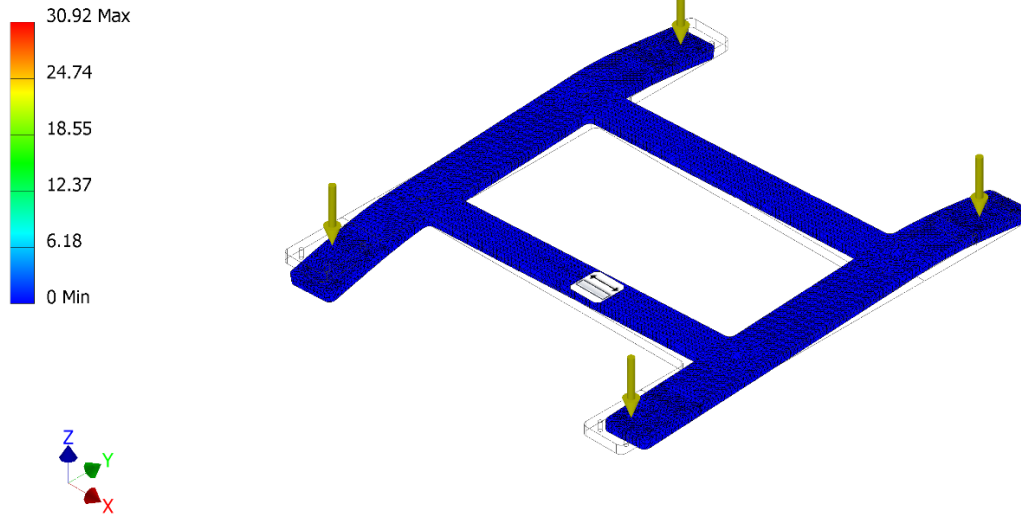

Figure 42 - H-shape fp, refined mesh 0.01, results Von Mises stress

Nodes:136967
Elements:84927
Type: Displacement
Unit: mm
5/24/2023, 9:22:29 PM

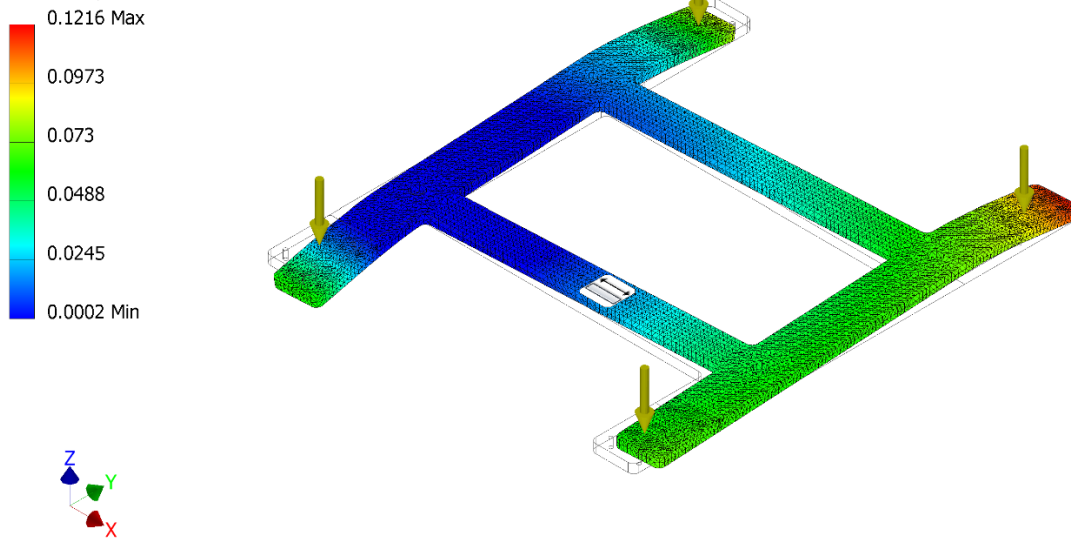

Figure 43 - H-shape fp, refined mesh 0.01, results displacement

ATTACHMENT B

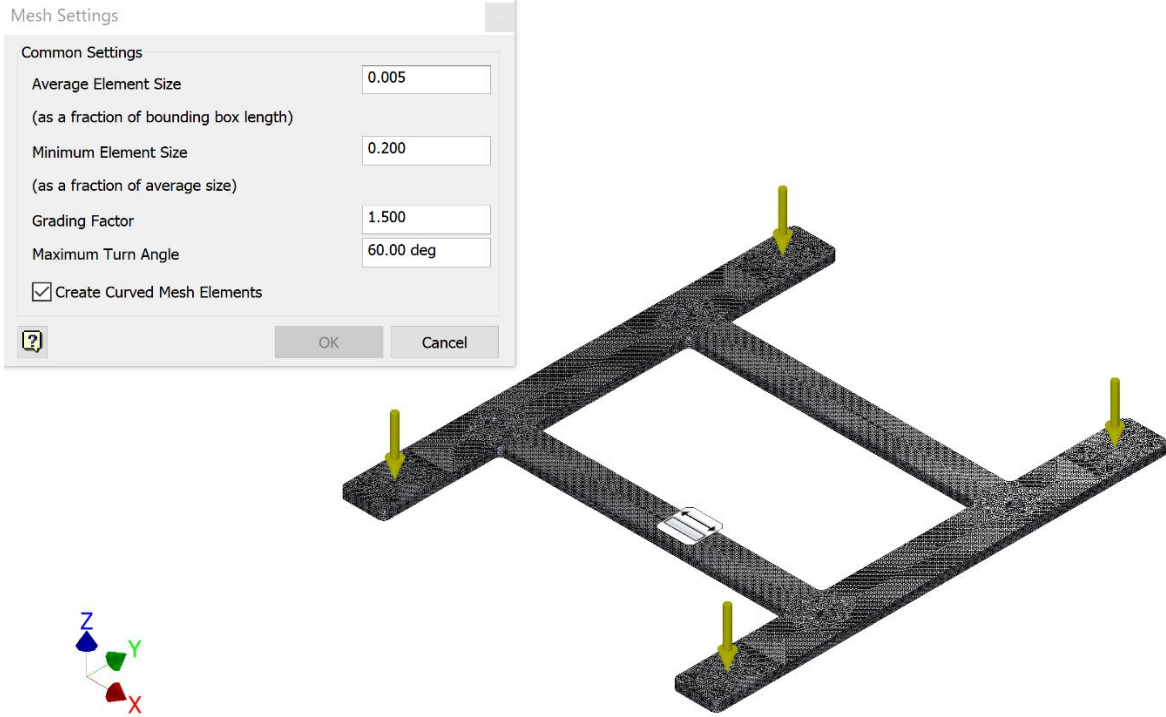

Figure 44 - H-shape fp, refined mesh 0.005, generated mesh with element size 0.005

Nodes:745216
Elements:496868
Type: Von Mises Stress
Unit: MPa
5/24/2023, 10:11:21 PM

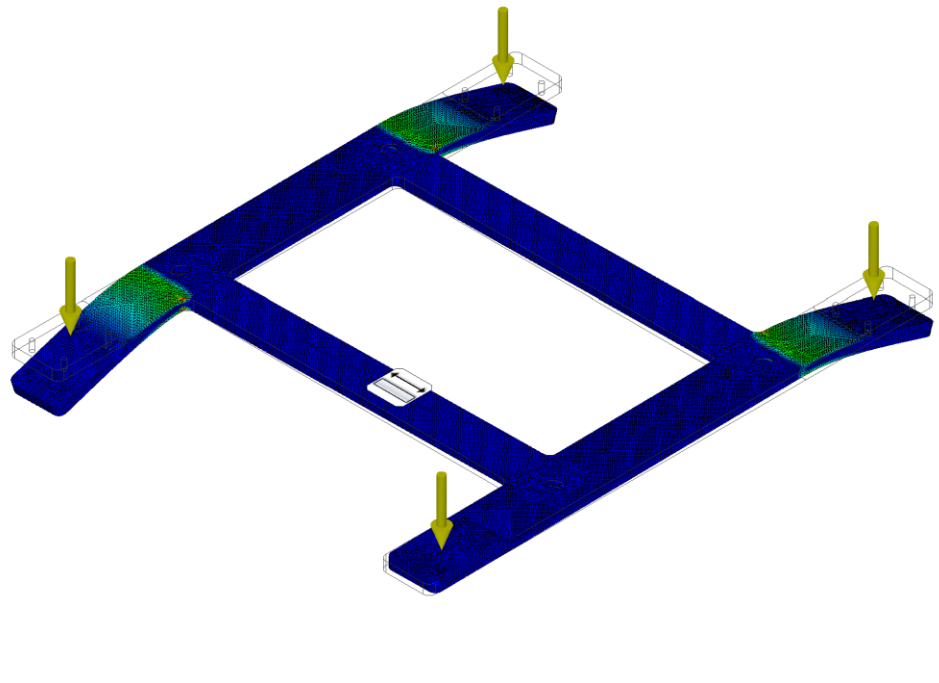
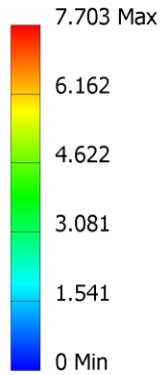

Figure 45 - H-shape fp, refined mesh 0.005, results Von Mises stress

ATTACHMENT B

Nodes:745216
Elements:496868
Type: Displacement
Unit: mm
5/24/2023, 10:12:09 PM

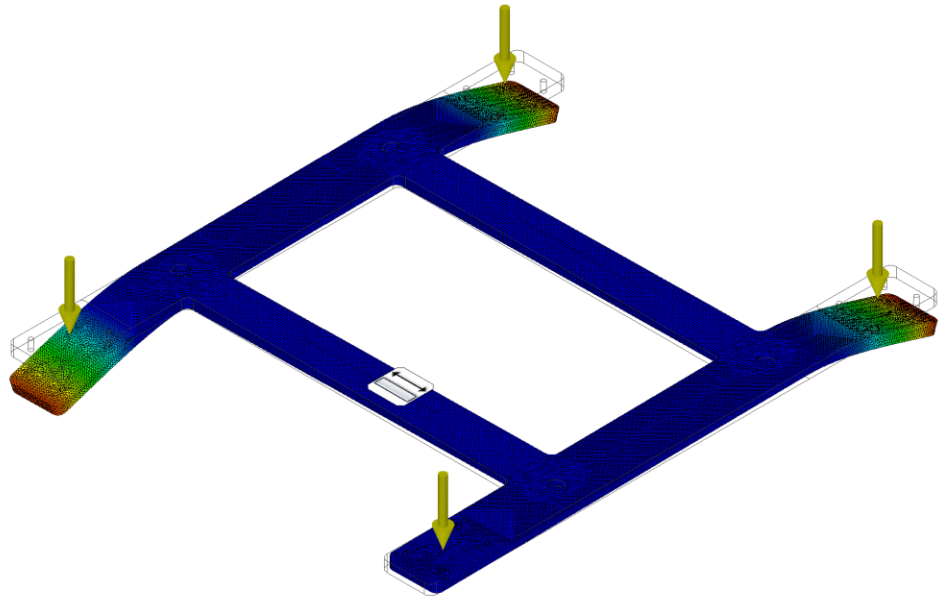
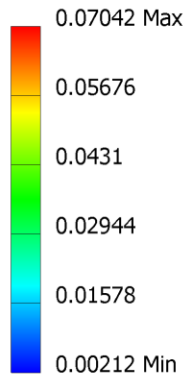

Figure 46 - H-shape fp, refined mesh 0.005, results displacement

Baseplate

Mesh Settings

Common Settings	
Average Element Size	0.010
(as a fraction of bounding box length)	
Minimum Element Size	0.200
(as a fraction of average size)	
Grading Factor	1.500
Maximum Turn Angle	60.00 deg
<input checked="" type="checkbox"/> Create Curved Mesh Elements	
[?] [OK] [Cancel]	

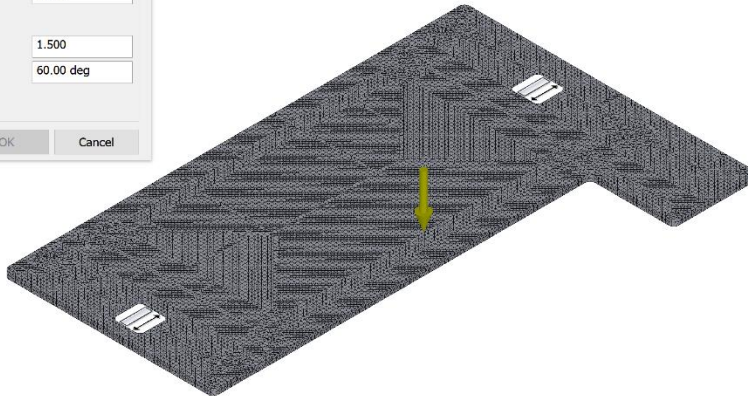

Figure 47 - H-shape bp, refined mesh, generated mesh with element size 0.01

ATTACHMENT B

Nodes:225241
Elements:134350
Type: Von Mises Stress
Unit: MPa
5/24/2023, 9:01:03 PM

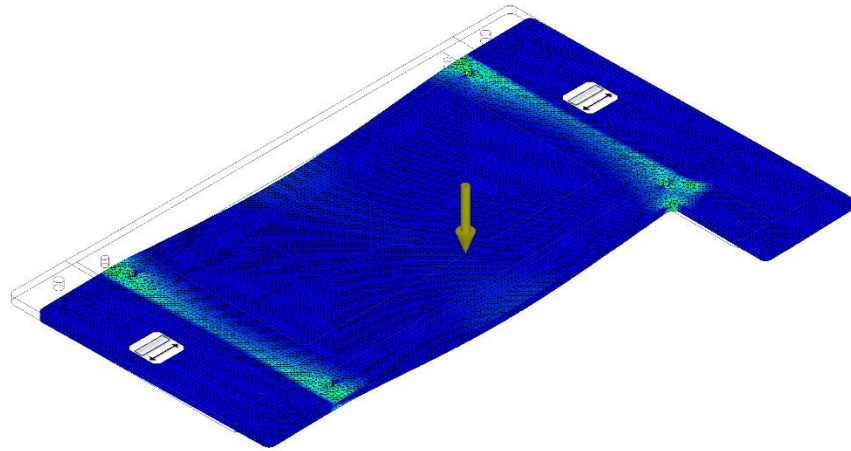
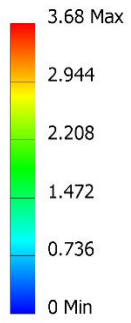

Figure 48 - H-shape bp, refined mesh 0.01, results Von Mises stress

Nodes:225241
Elements:134350
Type: Displacement
Unit: mm
5/24/2023, 9:01:30 PM

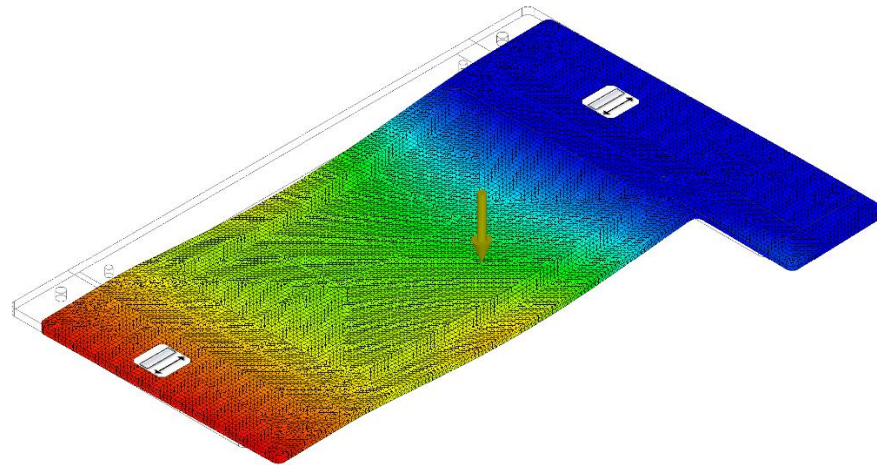
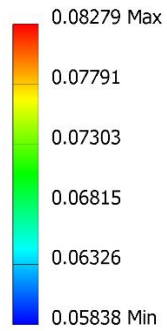

Figure 49 - H-shape bp, refined mesh 0.01, results displacement

ATTACHMENT B

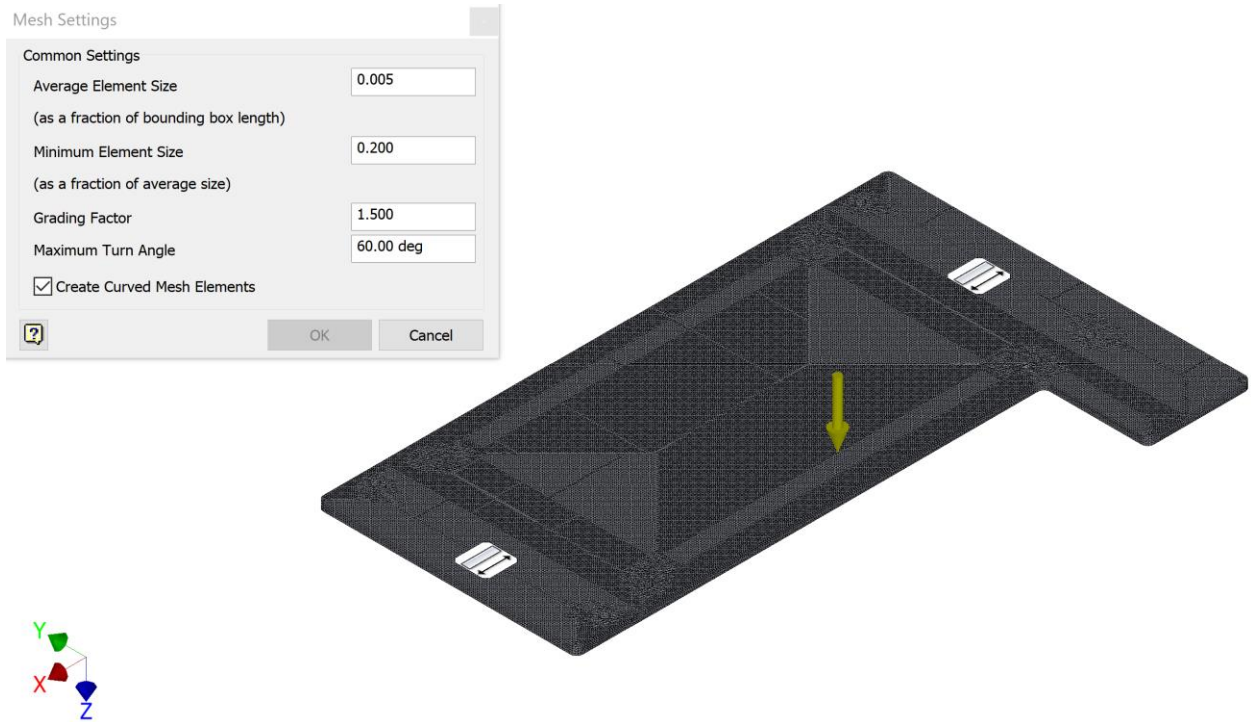

Figure 50 - H-shape bp, refined mesh 0.005, generated mesh with element size 0.005

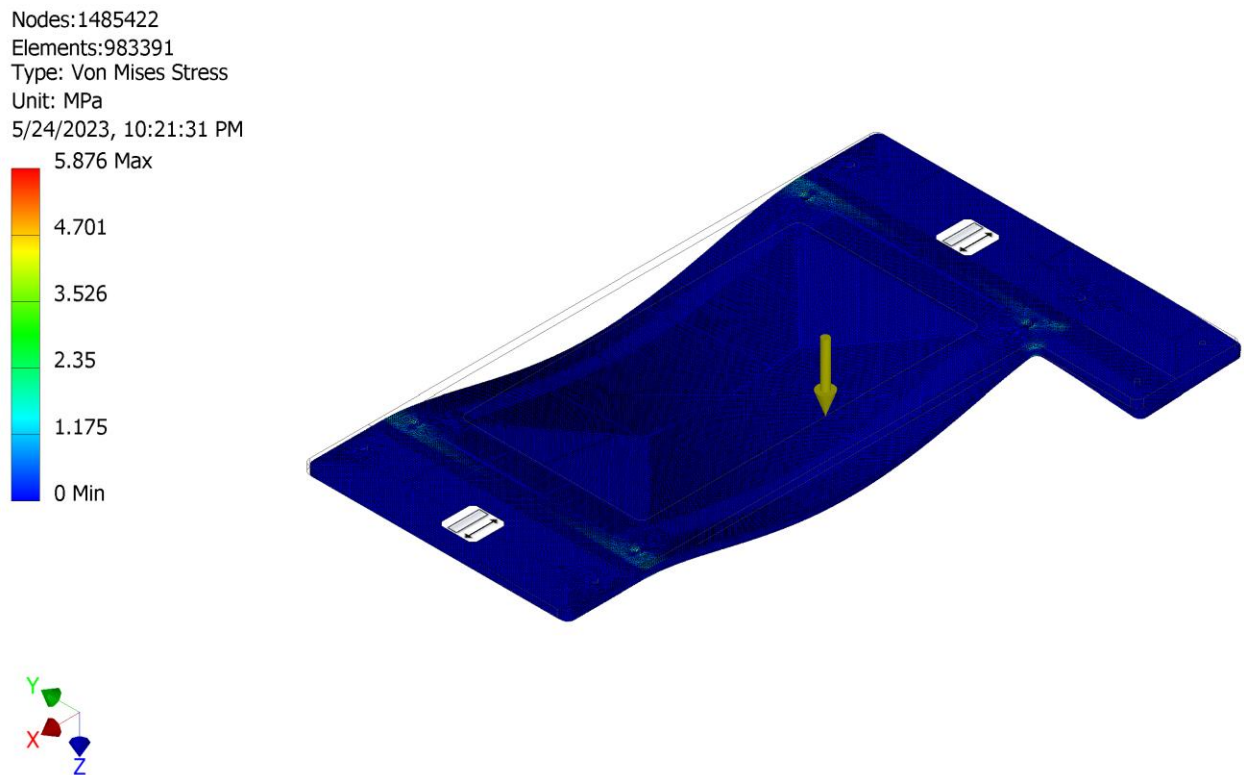

Figure 51 - H-shape bp, refined mesh 0.005, results Von Mises stress

ATTACHMENT B

Nodes:1485422
Elements:983391
Type: Displacement
Unit: mm
5/24/2023, 10:22:01 PM

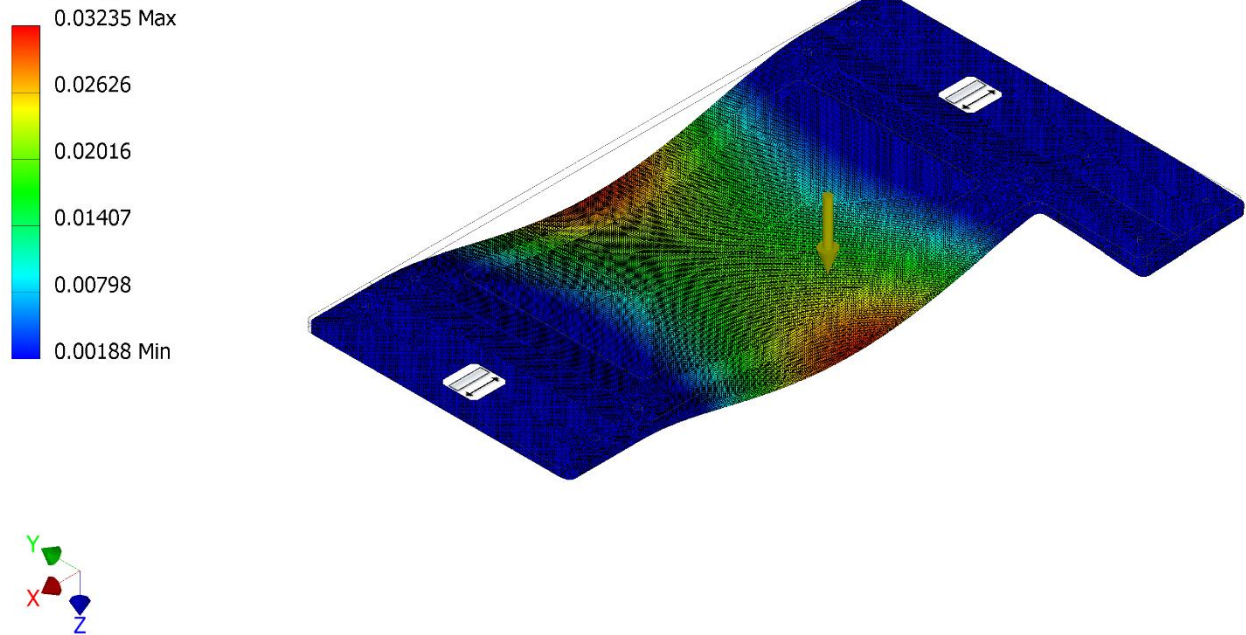

Figure 52 - H-shape bp, refined mesh 0.005, results displacement

Results Refined Mesh Summarize

Results are summarized in Table 1 below.

Table 2 - Results stress analysis

		Mesh 0.05	Mesh 0.01	Mesh 0.005
Bin fitment plate	Von Mises stress	11.3 MPa	30.92 MPa	7.703 MPa
	Displacement	0.07465 mm	0.1216 mm	0.07042 mm
Baseplate	Von Mises stress	3.204 MPa	3.68 MPa	5.876 MPa
	Displacement	0.3188 mm	0.08279 mm	0.03235 mm

When refining the mesh with element size 0.01, the results turn around; Now the Bin fitment is out of specifications, while the baseplate is within. By refining even more with element size 0.005, both plates are within specifications.

ATTACHMENT C.1

Note 1

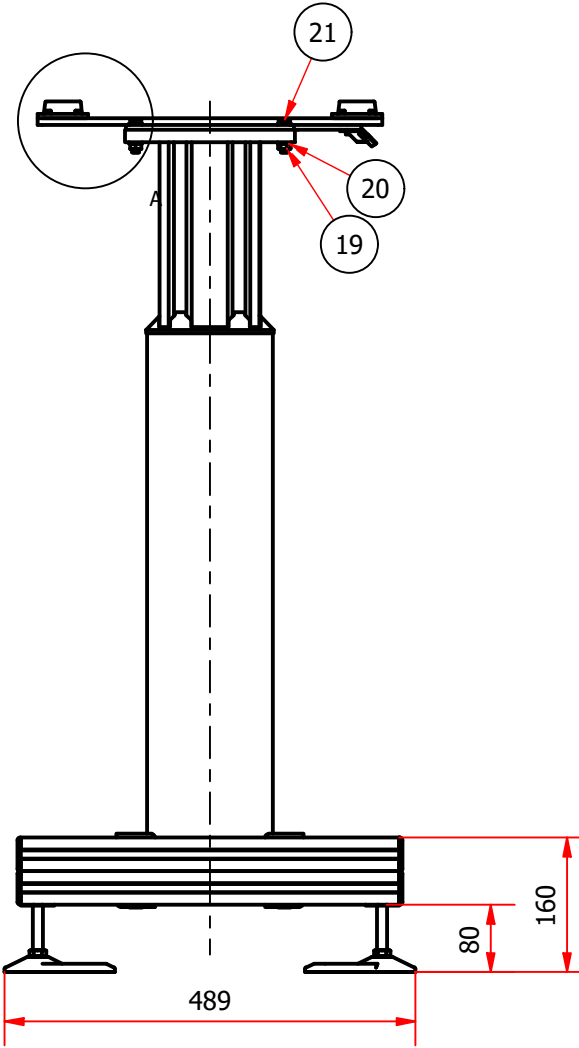
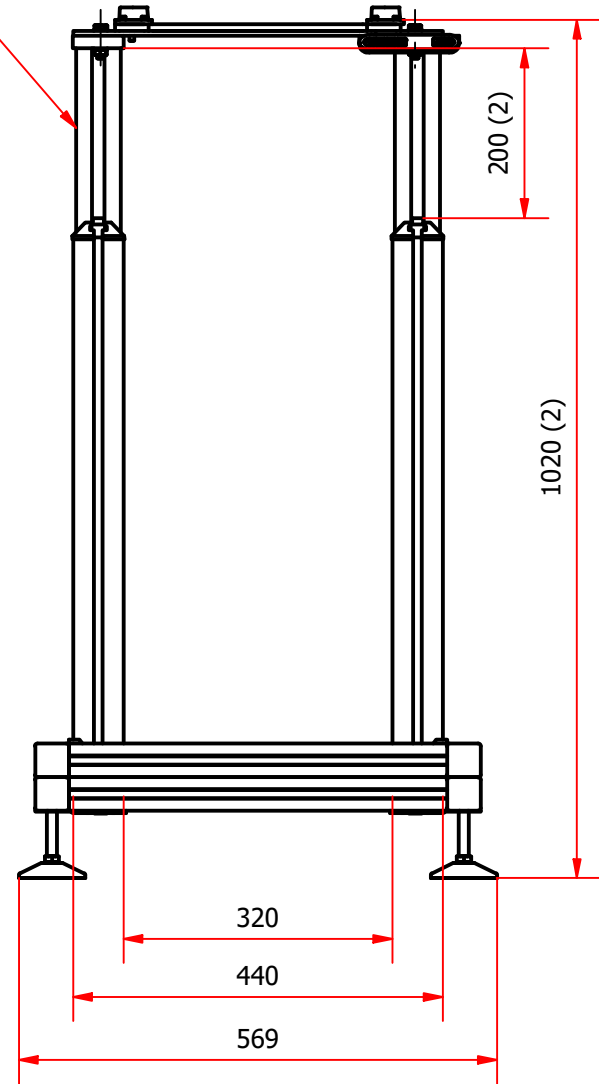

A (2:5)

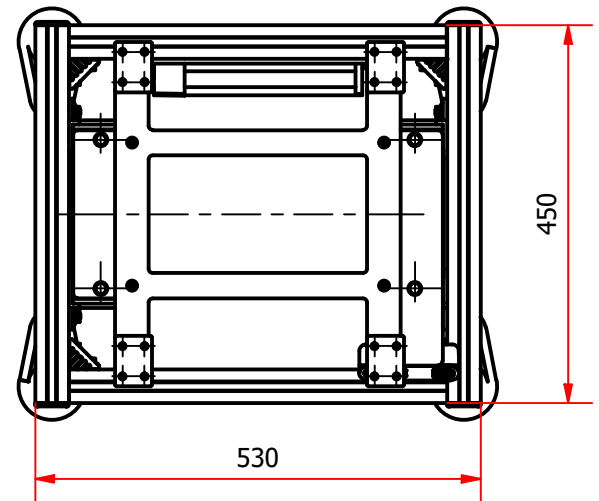
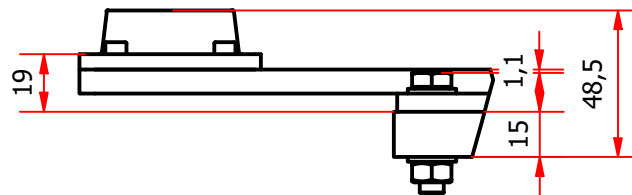

Parts List			
ITEM	QTY	PART NUMBER	DESCRIPTION
1	2	3842558629	Rexroth Lifting module, F1000, Lift 410mm
2	2	3842564145	Rexroth Holding bracket for Lift module
3	1	3842559940	Rexroth Hand switch
4	1	3842559921	Rexroth Control unit, F1000
5	8	AS12718 Profile L-450	Rexroth 40x40 profile, 3842993120
6	8	AS12039 Angle bracket 40x40	Rexroth Angle bracket 40x40 set, 3842529383
7	8	AS12151 Cap cover 40x40	Rexroth Cover Cap, 3842548747
8	4	AS14206 Oval base plate	Rexroth Oval base plate BR 3842538680
9	4	AS11829 Spindel M12	Rexroth Spindel 3842537224
10	1	PL300x80	Holding bracket for control unit
11	4	ISO 4762 - M4 x 6	Hexagon Socket Head Cap Screw
12	2	AS12153 T-Bolt M8x20	Rexroth T-nut, 3842528715
13	2	AS12155 Flange nut M8	Rexroth Flange nut, 3842345081
14	1	PL440x280	Baseplate
15	1	PL410x340	Bin fitment plate
16	4	DIN 6912 - M6 x 16	Cylinder Head Cap Screw
17	4	PL60x40	Alignment bracket
18	16	ISO 4762 - M4 x 10	Hexagon Socket Head Cap Screw
19	4	ISO 4032 - M8	Hex Nut. Product grades A and B
20	8	ISO 7089 - 8	Plain washers - Normal series - Product grade A
21	4	ISO 4017 - M8 x 35	Hex-Head Bolt

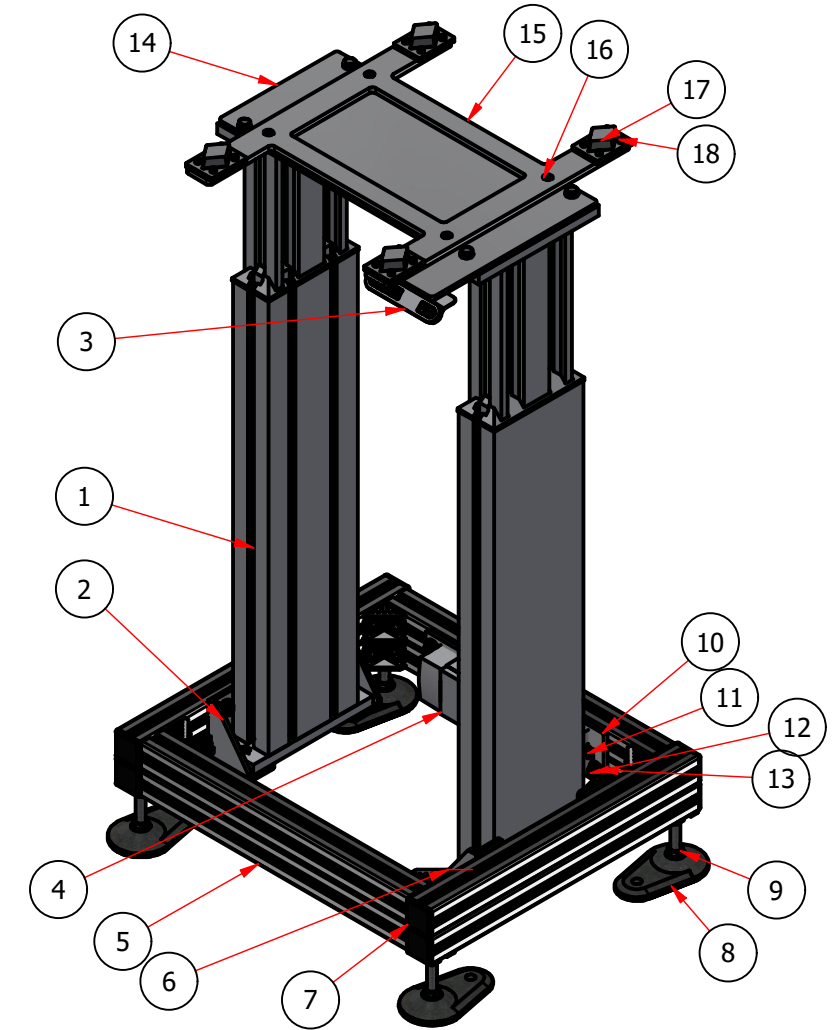

- Notes:
- Height adjustment range 0-410 mm.
Total height range of jig: 820 - 1230 mm
 - Height adjusted 200mm

Designed by IB	Date designed 5/7/2023	Approved by UG	Date approved 5/16/2023	Projection 	Sheet size A3
Autostore Technology AS Stokkastrandvegen 85, 5578 Nedre Vats, Norway		Description / Dimension Bin measuring jig		Material Aluminium	
This drawing / document is the property of Autostore Technology AS. The drawing and contents cannot be made public, copied or otherwise used without written consent by Autostore Technology AS.			Filename BMJ_assembly_electric.idw	Revision 0	Sheet 1 / 1

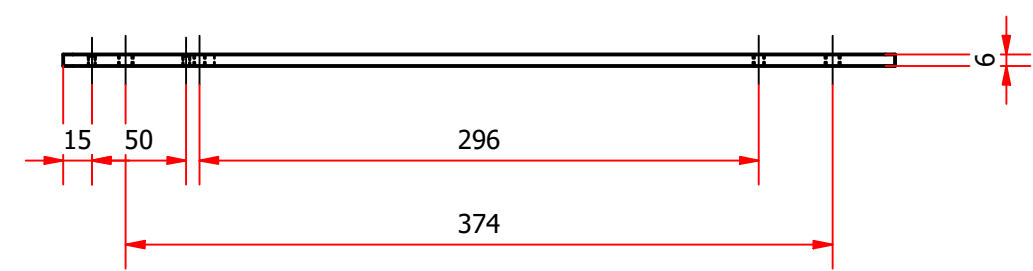
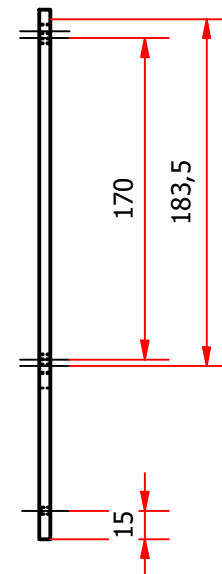
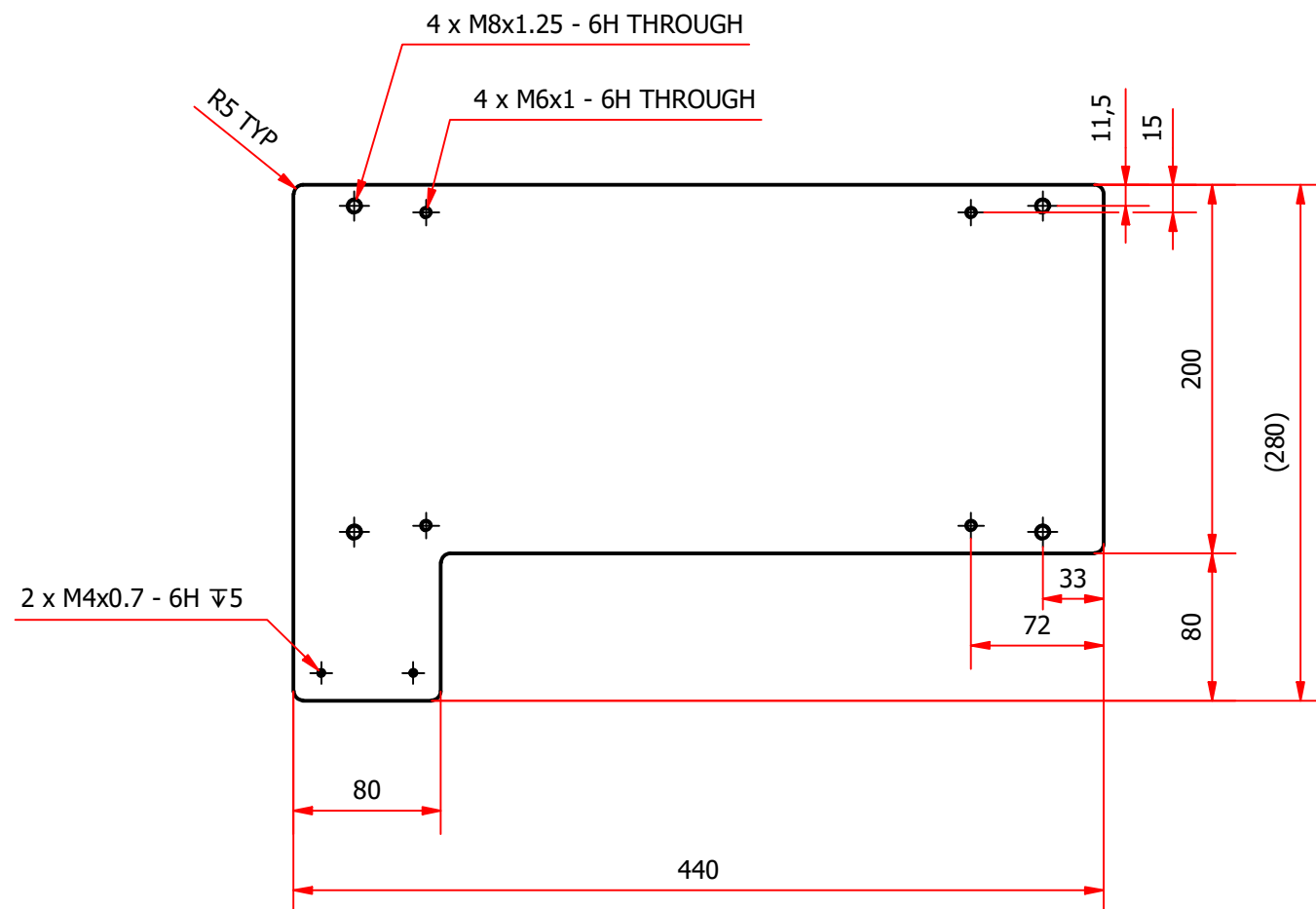

Model file name & path: C:\VAULTWORK\Designs\Bin\Test equipment\Measuring jig\Solution Concepts\PL 420x200.ipt

<p>TOLERANCES UNLESS OTHERWISE SPECIFIED</p> <p>Machined parts: Linear & angular dimensions: ISO 2768-1-1 Geometrical tolerances: ISO 2768-2-H Surface finish: MRR Ra 3,2</p> <p>Sheet metal parts: Size range 0-600: ± 0,30 Size range 600-1000: ± 0,50 Size range 1000-3000: ± 0,80 CSK thru holes: + 0,60 / - 0,00 Circular cutouts up to Ø8: + 0,20 / - 0,00 Circular cutouts over Ø8: + 0,30 / - 0,00 Angular dimensions: ISO 2768-1-1 Geometrical tolerances: ISO 2768-2-K</p> <p>Applicable GPS standard: ISO 9015 All dimensions: mm</p>	Designed by IB	Date designed 5/8/2023	Approved by UG	Date approved 5/16/2023	Projection 	Sheet size A3
	<p>AutoStore Autostore Technology AS Stokkastrandvegen 85, 5578 Nedre Vats, Norway</p> <p>This drawing / document is the property of Autostore Technology AS. The drawing and contents cannot be made public, copied or otherwise used without written consent by Autostore Technology AS.</p>	Description / Dimension Baseplate	Material Aluminum 5083 87 Cold Formed			
Filename PL 420x200.ipt		Revision 0	Sheet 1 / 1			

16 x M4x0.7 - 6H THRU

Ø6,4 THRU
 □ Ø12 ▽ 4,5

R5 TYP

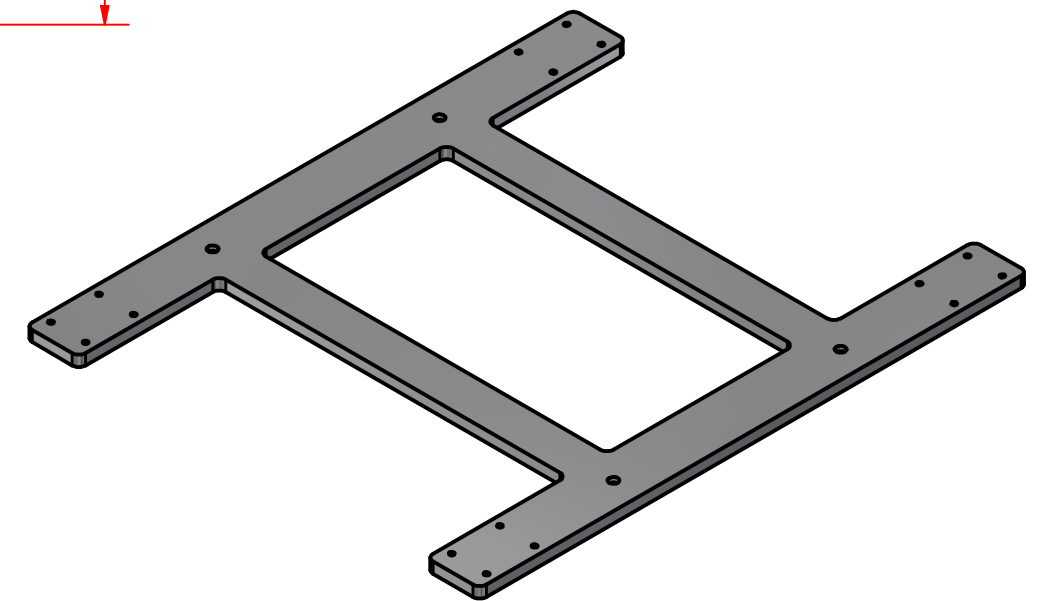
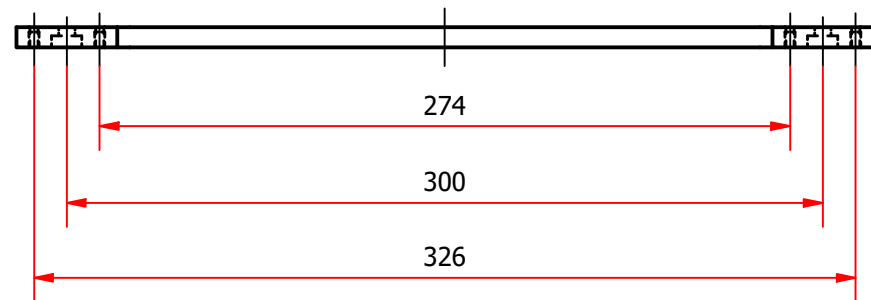
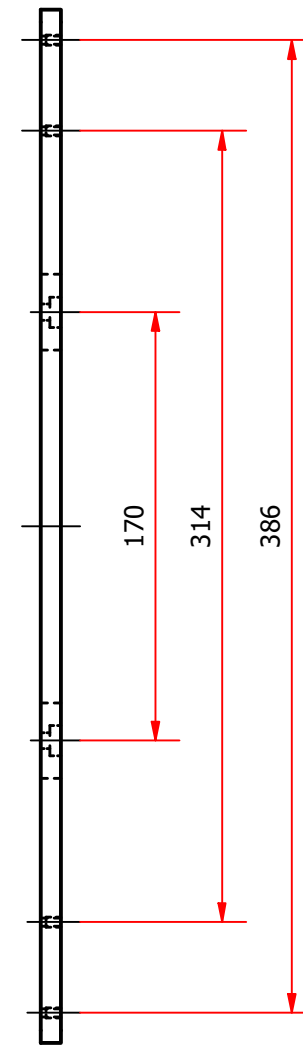
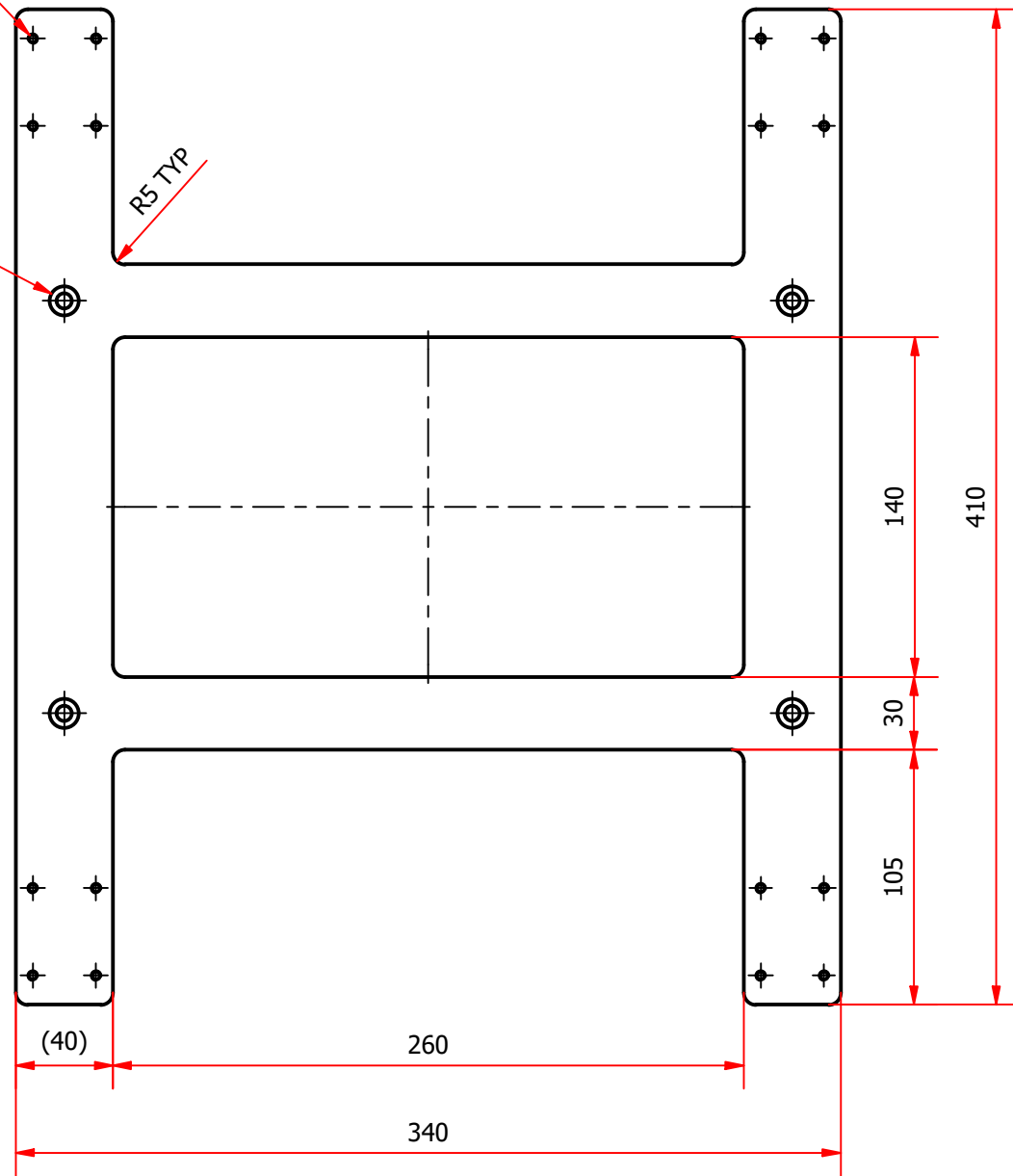

Model file name & path: C:\VAULTWORK\Designs\Bin\Test equipment\Measuring jig\Detailing & Final product\PL410x340.ipt

<p>TOLERANCES UNLESS OTHERWISE SPECIFIED</p> <p>Machined parts: Linear & angular dimensions: ISO 2768-1-1 Geometrical tolerances: ISO 2768-2-H Surface finish: MRR Ra 3,2</p> <p>Sheet metal parts: Size range 0-600: ± 0,30 Size range 600-1000: ± 0,50 Size range 1000-3000: ± 0,80 CSK thru holes: + 0,50 / - 0,00 Circular cutouts up to Ø8: + 0,20 / - 0,00 Circular cutouts over Ø8: + 0,30 / - 0,00 Angular dimensions: ISO 2768-1-1 Geometrical tolerances: ISO 2768-2-K</p> <p>Applicable GPS standard: ISO 9015 All dimensions: mm</p>	Designed by	Date designed	Approved by	Date approved	Projection	Sheet size
	10761	5/12/2023	UG	5/24/2023		A3
<p>AutoStore Autostore Technology AS Stokkastrandvegen 85, 5578 Nedre Vats, Norway</p>	Description / Dimension		Material			
This drawing / document is the property of Autostore Technology AS. The drawing and contents cannot be made public, copied or otherwise used without written consent by Autostore Technology AS.		Bin fitment plate		Aluminum 5083 87 Cold Formed		
Filename		Revision		Sheet		
PL410x340.ipt		0		1 / 1		

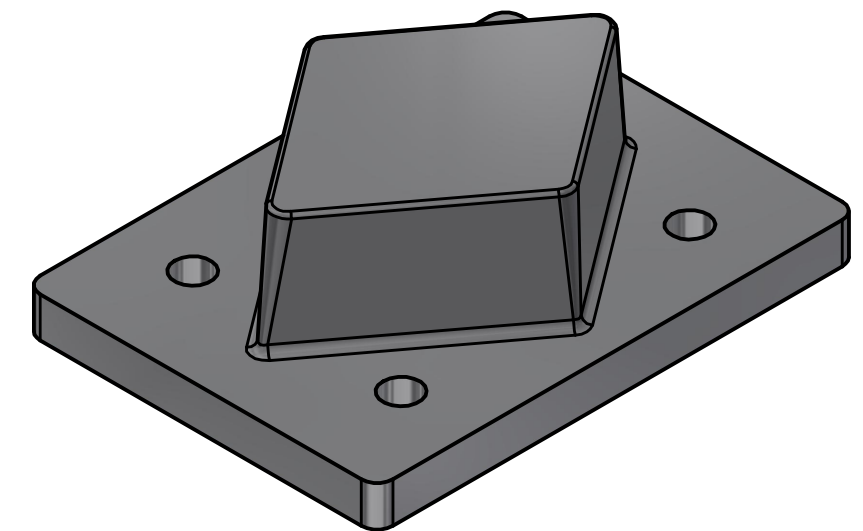
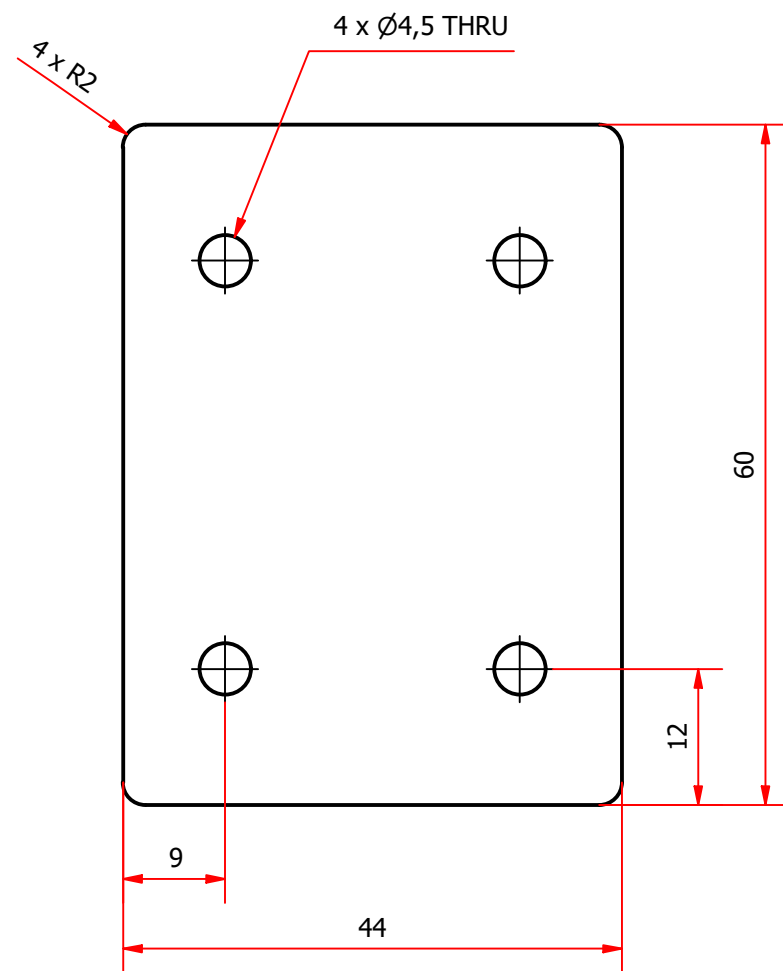
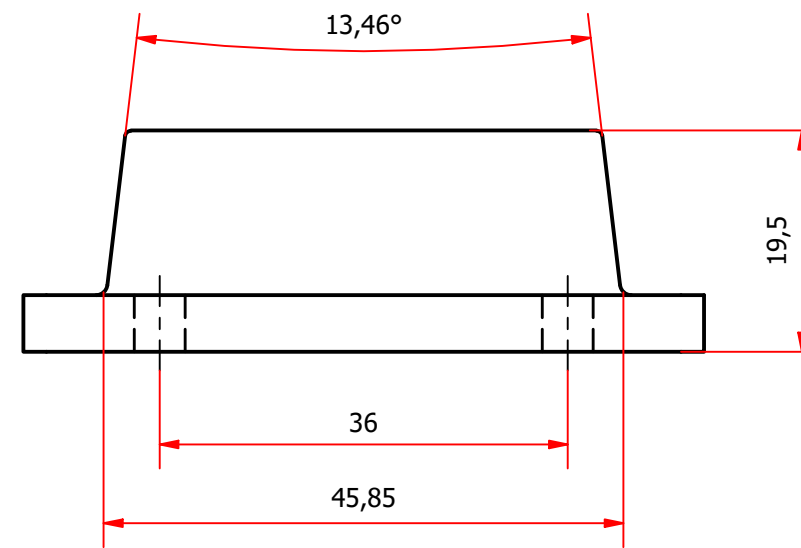
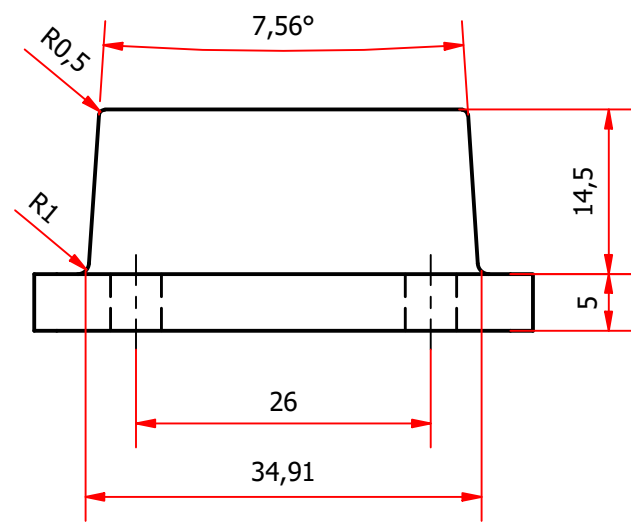

<p>TOLERANCES UNLESS OTHERWISE SPECIFIED</p> <p>Machined parts: Linear & angular dimensions: ISO 2768-1-F Geometrical tolerances: ISO 2768-2-H Surface finish: MRR Ra 3,2</p> <p>Sheet metal parts: Size range 0-600: ± 0,30 Size range 600-1000: ± 0,50 Size range 1000-3000: ± 0,80 CSK thru holes: + 0,60 / - 0,00 Circular cutouts up to Ø8: + 0,20 / - 0,00 Circular cutouts over Ø8: + 0,30 / - 0,00 Angular dimensions: ISO 2768-1-F Geometrical tolerances: ISO 2768-2-K</p> <p>Applicable GPS standard: ISO 9015 All dimensions: mm</p>	Designed by	Date designed	Approved by	Date approved	Projection	Sheet size
	<p>IB</p> <p>AutoStore Autostore Technology AS Stokkastrandvegen 85, 5578 Nedre Vats, Norway</p> <p>This drawing / document is the property of Autostore Technology AS. The drawing and contents cannot be made public, copied or otherwise used without written consent by Autostore Technology AS.</p>	5/15/2023	UG	5/24/2023		A3
	Description / Dimension			Material		
	Alignment bracket			Aluminum 5083 87 Cold Formed		
	Filename			Revision		Sheet
	PL60x40.ipt			0		1 / 1

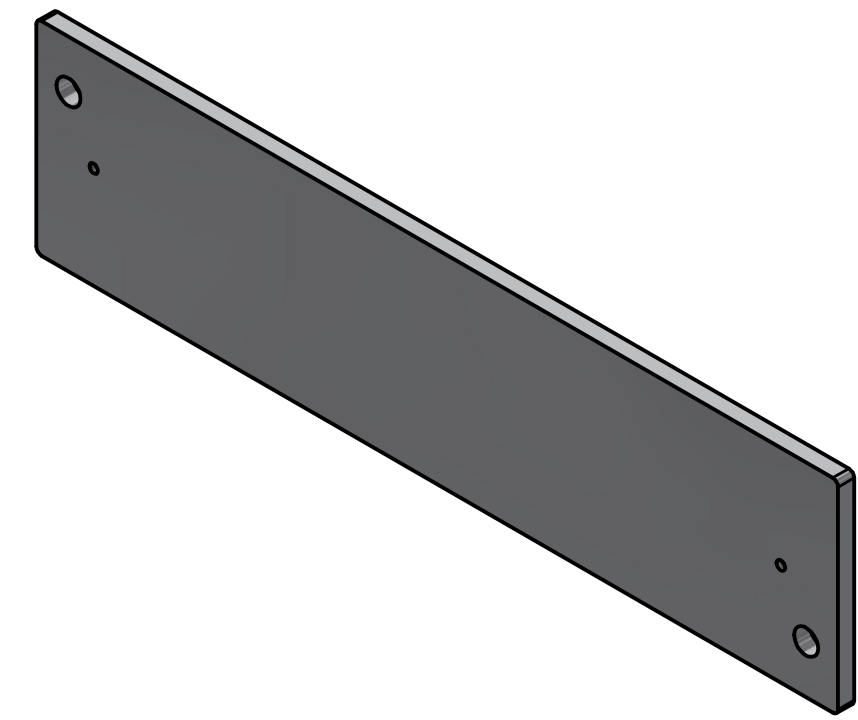
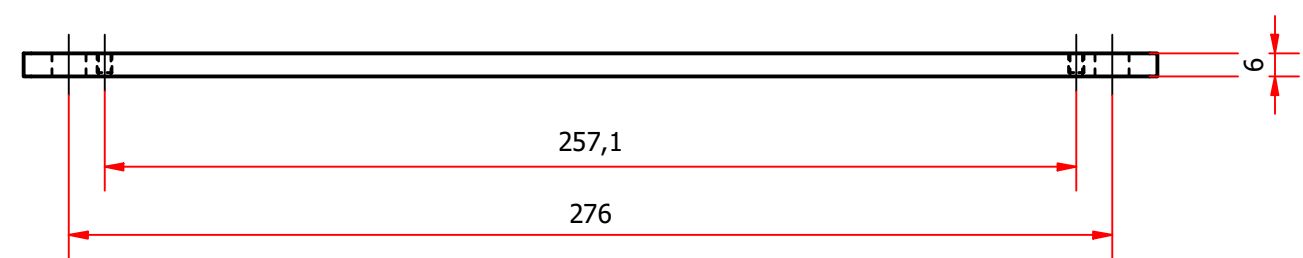
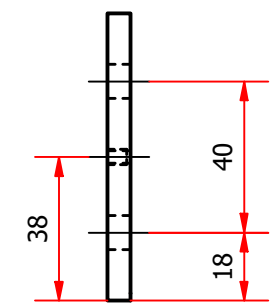
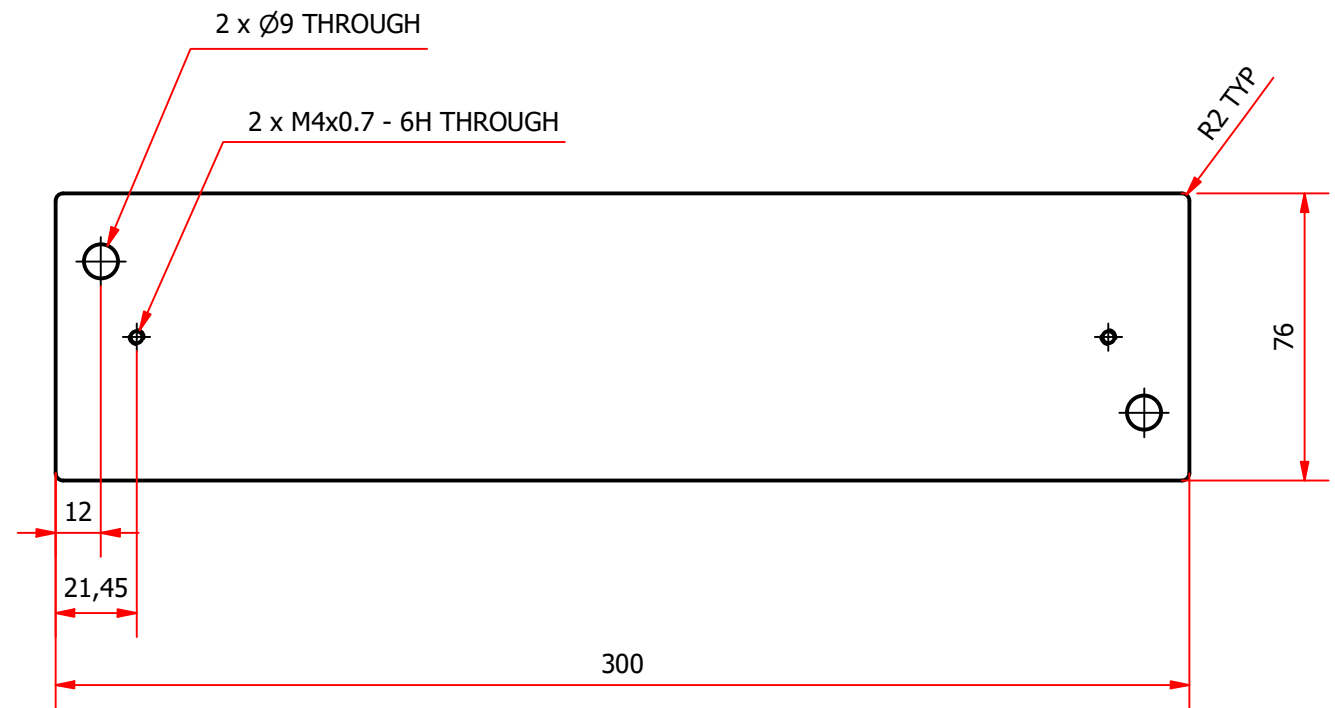

<p>TOLERANCES UNLESS OTHERWISE SPECIFIED</p> <p>Machined parts: Linear & angular dimensions: ISO 2768-1-4 Geometrical tolerances: ISO 2768-2-H Surface finish: MRR Ra 3,2</p> <p>Sheet metal parts: Size range 0-600: ± 0,30 Size range 600-1000: ± 0,50 Size range 1000-3000: ± 0,80 CSK thru holes: + 0,60 / - 0,00 Circular cutouts up to Ø8: + 0,20 / - 0,00 Circular cutouts over Ø8: + 0,30 / - 0,00 Angular dimensions: ISO 2768-1-4 Geometrical tolerances: ISO 2768-2-K</p> <p>Applicable GPS standard: ISO 9015 All dimensions: mm</p>	Designed by	Date designed	Approved by	Date approved	Projection	Sheet size	
	<p>IB</p> <p>AutoStore Autostore Technology AS Stokkastrandvegen 85, 5578 Nedre Vats, Norway</p>	5/15/2023	UG	5/16/2023		A3	
<p>This drawing / document is the property of Autostore Technology AS. The drawing and contents cannot be made public, copied or otherwise used without written consent by Autostore Technology AS.</p>	Description / Dimension Holding bracket for control unit		Material Aluminum 5083 87 Cold Formed		Filename PL300x80.ipt	Revision 0	Sheet 1 / 1

Lifting module

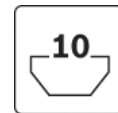

- Three lifting modules with different maximum lifting and pressure forces as well as lifting velocities for the continuous height adjustment of workplaces even under high loads.

[PDF](#) Assembly instructions

- Three lifting lengths per variant
- Attachment by means of mounting plates at the face sides or using the integrated 10 mm slot
- Incl. Connection cable; cable length: ~2m
- Cable possible on the left or right side
- Diagonal cover cap prevents crushing risk
- All lifting modules are electrostatic discharge-enabled
- Mounting plates are connected in a conductive manner
- Attachment bracket set suitable for F1000, F1600 or F3200 lifting modules for lateral profile attachment (grid dimension 45mm)
- Note:** According to **IEC 60204-1:2016 - 15** Socket-outlets and lighting - Socket-15.1 outlets for accessories: Where the machine or its associated equipment is provided with socket-outlets that are intended to be used for accessory equipment (for example hand-held power tools, testequipment), the following apply:[...] – circuits supplying socket-outlets with a current rating not exceeding 20 A shall be provided with residual current protection (RCDs) with a rated operating current not exceeding 30 mA.

Product description

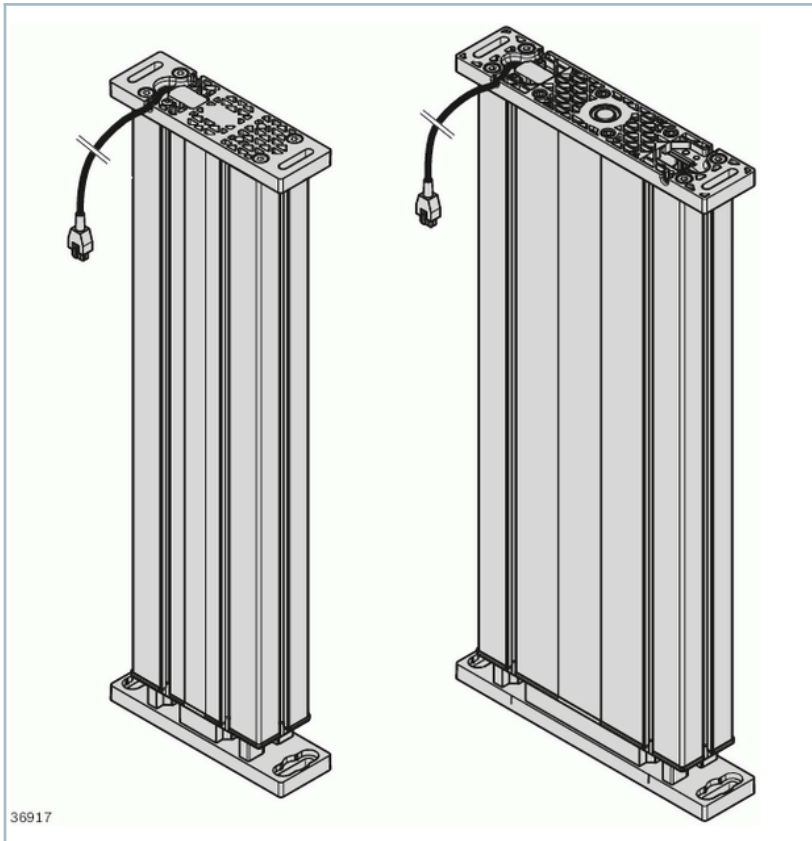

Technical data

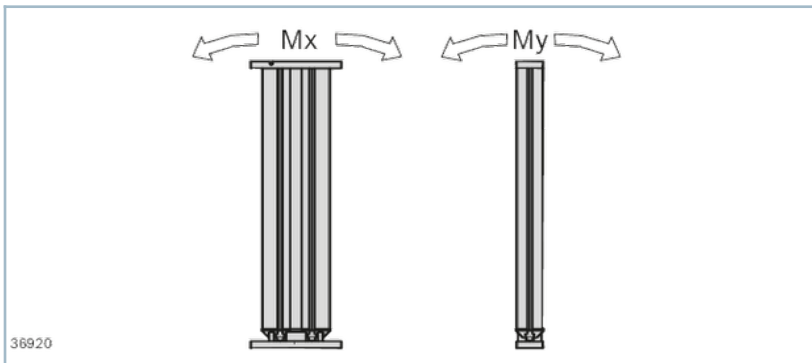

Load version	N	1000			1600			3200		
Stroke length	mm	350	410	500	350	440	500	350	440	500
Lifting velocity	mm/s	25			18			9		
Max. load, pressure	N	1000			1600			3200		
Max. load, pulling	N	500			1200			1600		
Perm. tilting torque M_x	Nm	300						500		
Perm. tilting torque M_y	Nm	125						250		

Fields of application

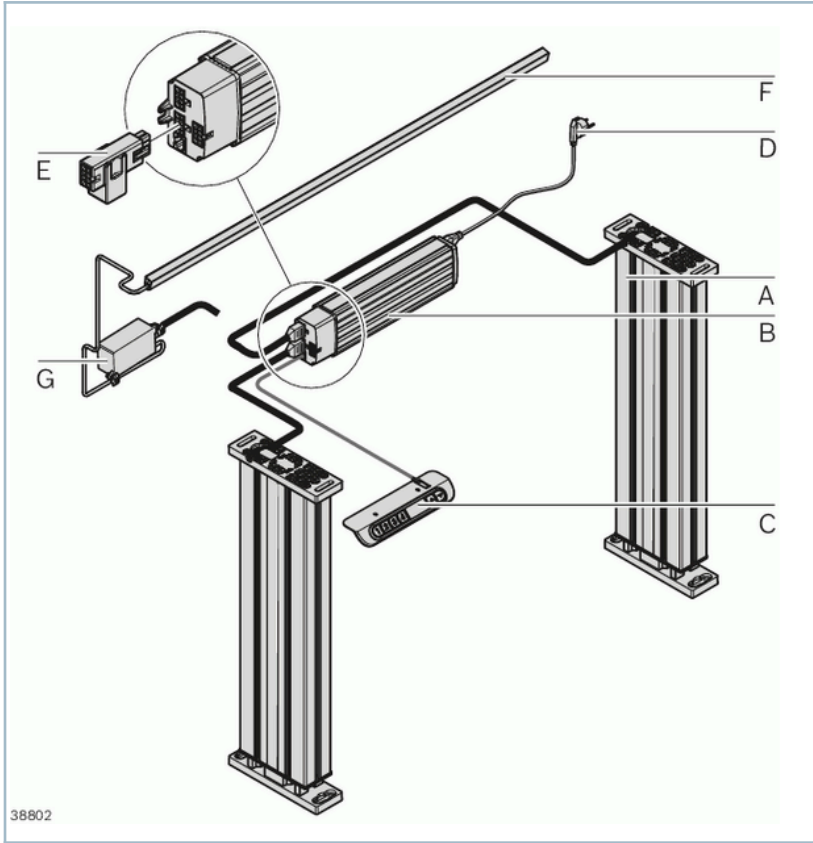

Dimensions

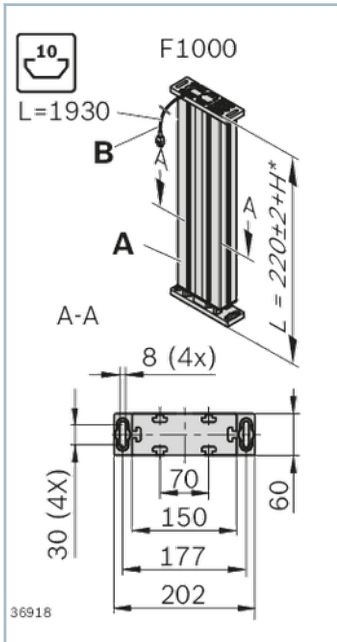

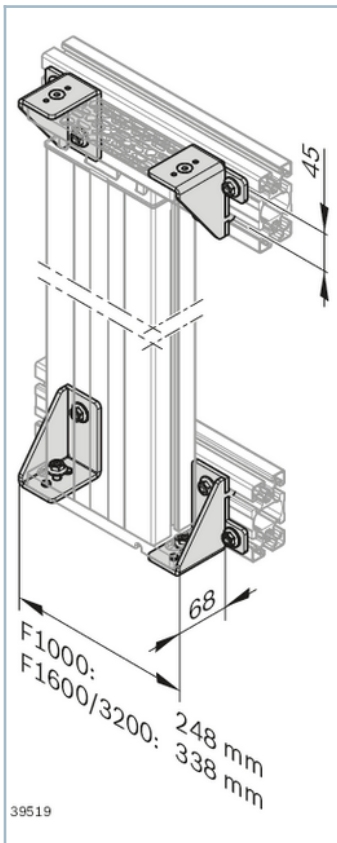
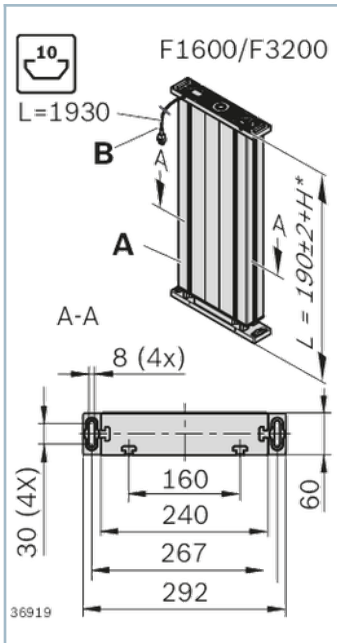

Ordering codes

	Load version	Stroke length	No.
	N	mm	
Lifting module F1000-LIFT350MM	1000	350	3842559967
Lifting module F1000-LIFT410MM	1000	410	3842558629
Lifting module F1000-LIFT500MM	1000	500	3842559965
Lifting column F1600-LIFT350MM	1600	350	3842559963
Lifting column F1600-LIFT440MM	1600	440	3842558627
Lifting column F1600-LIFT500MM	1600	500	3842559961
Lifting column F3200-LIFT350MM	3200	350	3842559959
Lifting column F3200-LIFT440MM	3200	440	3842558625
Lifting column F3200-LIFT500MM	3200	500	3842559957
Holding bracket Lift module ¹⁾	1000 ... 3200		3842564145
Holding bracket lift module set ²⁾	1000 ... 3200		3842564155

1) 2x2: 4 x including fastening material (suitable) for one lifting module; weight: 1.8 kg; material: Steel; galvanized

2) 2x20: 40 x (suitable) for ten lifting modules

Haltewinkel Lift Module
Holding bracket Lift Module
Piece d'angle Lift Module
Squadra di fissagg Lift Module
Angulo de fijacion Lift Module
Suporte angular Lift Module

3 842 564 164/2021-05

Replaces: -

DE+EN+FR+IT+ES+PT



3842564164

Montageanleitung • Assembly instructions • Instructions de montage
 Istruzioni per il montaggio • Instrucciones de montaje • Instruções de montagem

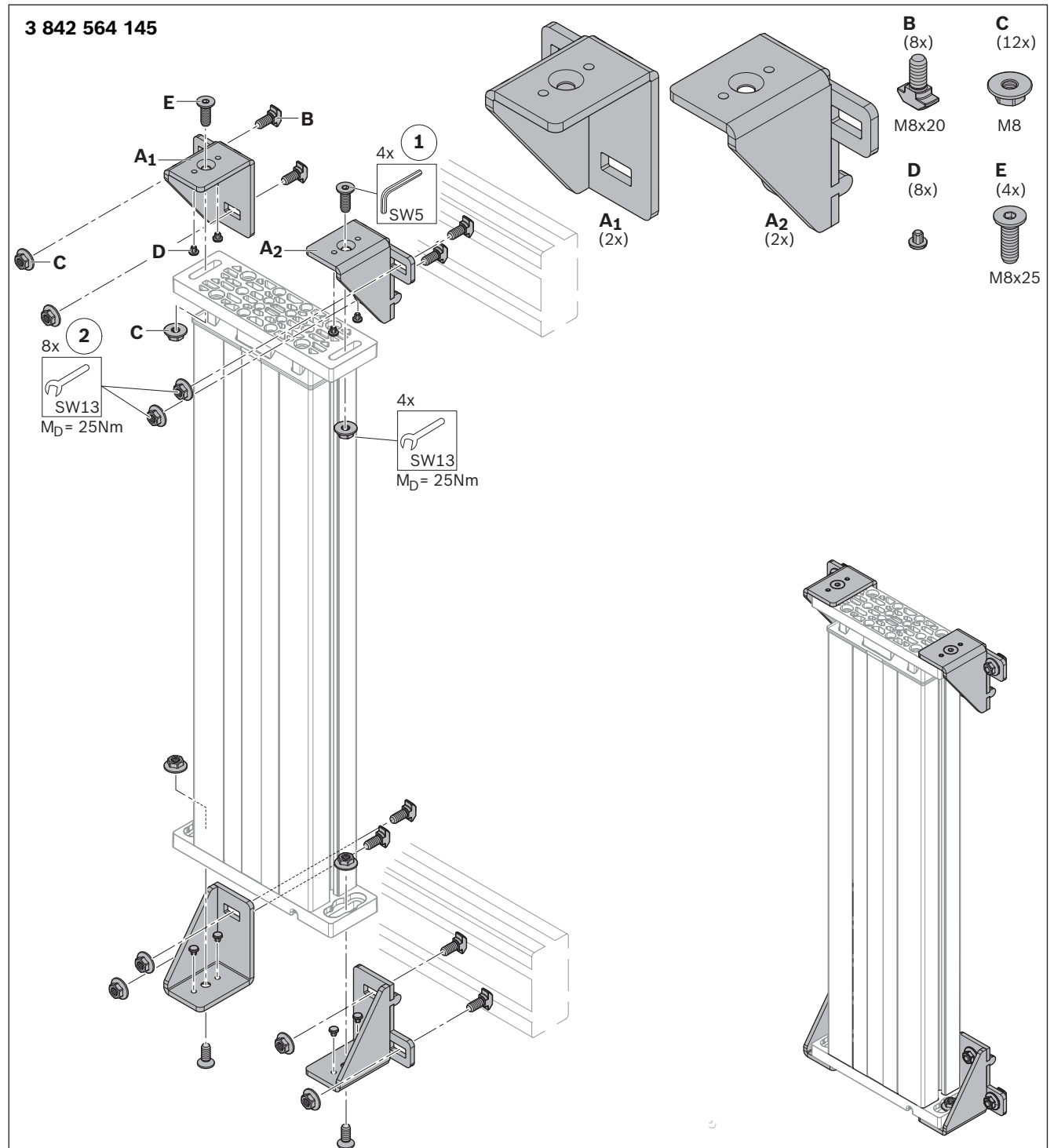

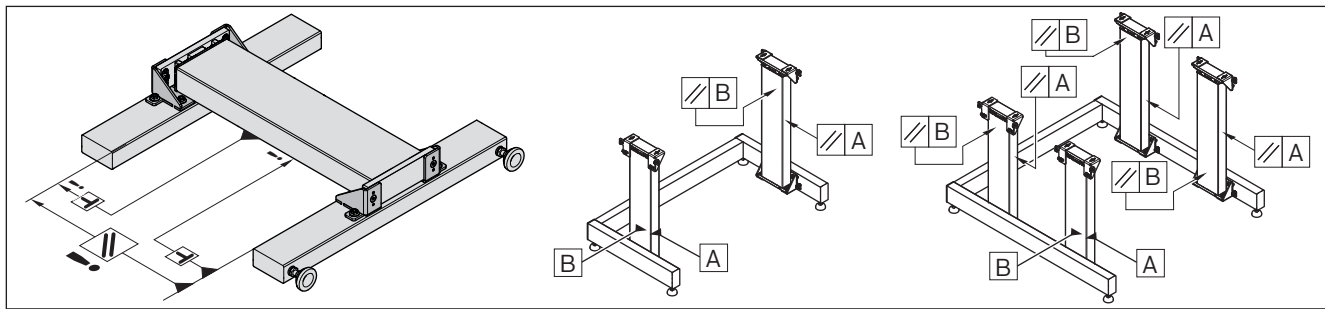

564 164-02

DE	<p>Anmerkungen zur Montage:</p> <ul style="list-style-type: none"> • Hubmodul nur in eingefahrenem Zustand montieren. • Auf Parallelität achten. • Verspannungsfrei montieren. <p>Die technischen Daten gelten für die einzelnen Hubmodule. Bei Systemen mit mehreren Hubmodulen ist zu berücksichtigen, dass es durch Fertigungs- und Montagetoleranzen zu erhöhter Reibung und Verspannungen kommt. Daher sollten die genannten Werte nur zu max. 80 % ausgenutzt werden. Das erhöht die Lebensdauer und verbessert das Regelverhalten.</p>
EN	<p>Notes on installation:</p> <ul style="list-style-type: none"> • Only install the lifting module if it is retracted. • Check for parallelism. • Install the free from distortion. <p>The technical data applies for individual lifting modules. In systems with several lifting modules, it must be taken into account that increased friction and torsion occurs due to manufacturing and installation tolerances. For this reason, the specified values should only be applied by max. 80%. This leads to an increase in service life and improved control behavior.</p>
FR	<p>Remarque sur le montage :</p> <ul style="list-style-type: none"> • Monter le module de levée uniquement en position rentrée. • Veiller au parallélisme. • Monter sans renforcement. <p>Les caractéristiques techniques sont valables pour les modules de levée individuels. Sur des systèmes avec plusieurs modules de levée, il convient de tenir compte du fait que les frottements et les tensions peuvent augmenter à cause des tolérances de production et de montage. Les valeurs données doivent donc être exploités à seulement 80 % max. Cela permet d'augmenter la durée de vie et améliore le comportement de régulation.</p>
IT	<p>Avvertenze per il montaggio:</p> <ul style="list-style-type: none"> • Montare il modulo di sollevamento solo quando introdotto. • Prestare attenzione al parallelismo. • Montare in assenza di tensione. <p>I dati tecnici si applicano ai singoli moduli di sollevamento. Nei sistemi con più moduli di sollevamento è necessari considerare che le tolleranze di fabbricazione e di montaggio provocano un maggiore attrito. I valori indicati dovrebbero pertanto essere sfruttati all'80 % max. Ciò prolunga la durata e migliora il comportamento di regolazione.</p>
ES	<p>Observaciones relativas al montaje:</p> <ul style="list-style-type: none"> • montar el módulo de elevación únicamente cuando se encuentre en estado retraído; • prestar atención al paralelismo; • montar sin tensiones. <p>Los datos técnicos tienen validez para los distintos módulos de elevación. En los sistemas con varios módulos de elevación se debe tener en cuenta que debido a las tolerancias de acabado y montaje se producen una mayor fricción y tensiones. Por ello se deben utilizar los valores mencionados únicamente al 80 % como máximo. Esto incrementa la vida útil y mejora el comportamiento de regulación.</p>
PT	<p>Observações relativas à montagem:</p> <ul style="list-style-type: none"> • Montar o módulo de elevação somente em estado recolhido. • Atente para o paralelismo. • Montar livre de tensão. <p>Os dados técnicos aplicam-se aos módulos de elevação individuais. No caso de sistemas com vários módulos de elevação, deve-se considerar que ocorre um aumento no atrito e na tensão pelas tolerâncias de fabricação e montagem. Por isso, os valores mencionados devem ser explorados só até 80% no máx. Isso aumenta a vida útil e melhora o comportamento de regulação.</p>



Control unit, hand switch

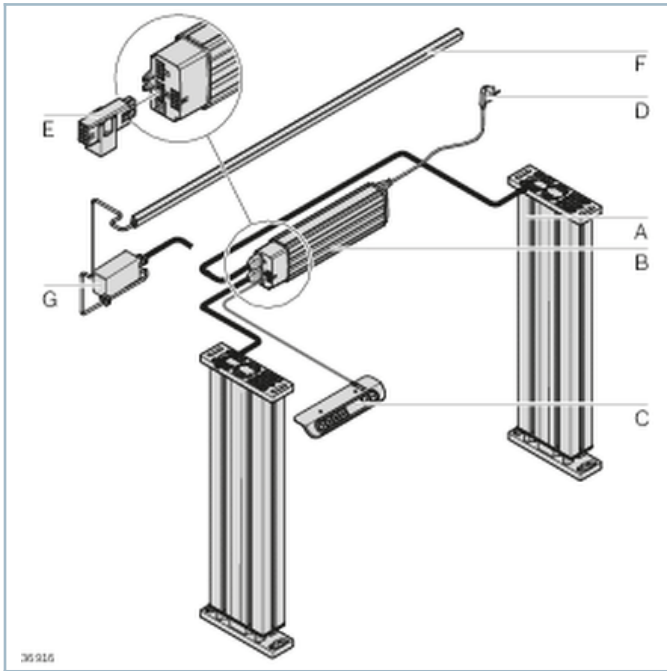

- B→Control unit
- C→Hand switch

[PDF](#) Assembly instructions

Product description

Control unit (B)

- Control for synchronization of 1, 2, or 3 lifting modules in parallel operation
- Duty cycle: 10% (= 2 min ON, 18 min OFF)

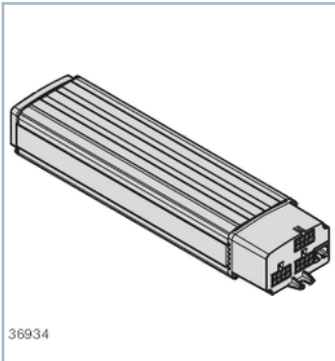

Hand switch (C)

- For operating the controller, with push button for height adjustment and 4 memory buttons to store the different positions, with display, cable length: ~ 1.8 m

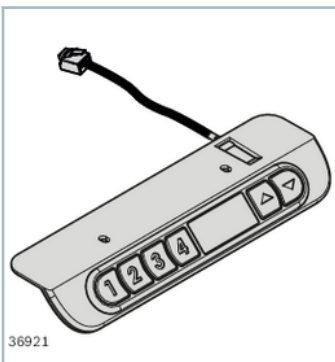

Fields of application

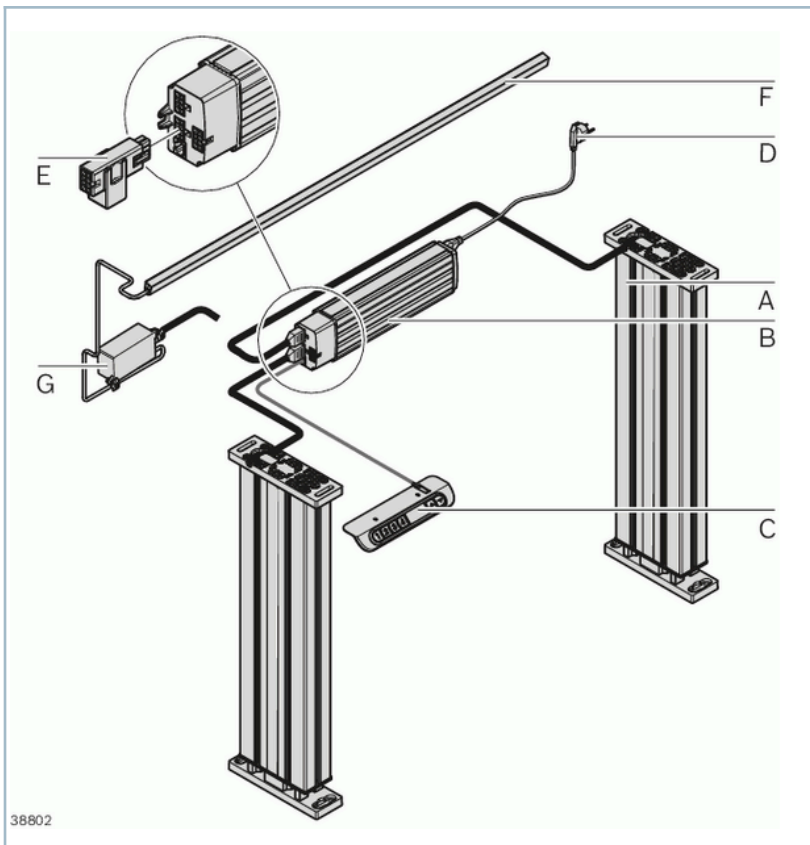

Dimensions

Control unit

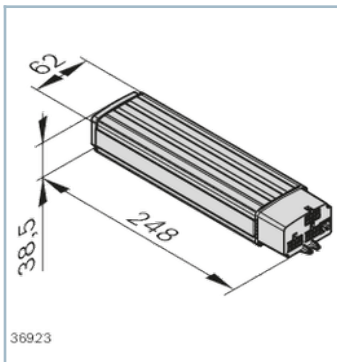

Ordering parameter with configurable material number

		3842559921	3842559922	3842559923	3842559931	3842559932	3842559933	3842559940
--	--	------------	------------	------------	------------	------------	------------	------------

Hand switch

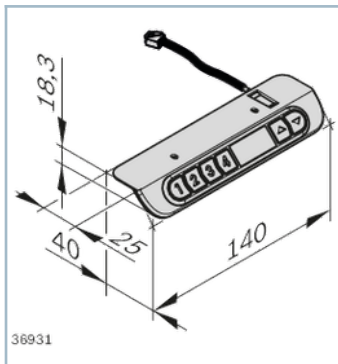

Delivery notes

Scope of delivery

Control unit F1000; EU	Incl. fastening material
Control unit F1600; EU	
Control unit F3200; EU	
Control unit F1000; NA	
Control unit F1600; NA	
Control unit F3200; NA	
Hand switch	

Ordering codes

	Load version	Voltage	No.
	N	V	
Control unit F1000; EU	1000	230 V	3842559921
Control unit F1600; EU	1600	230 V	3842559922
Control unit F3200; EU	3200	230 V	3842559923
Control unit F1000; NA	1000	120 V	3842559931
Control unit F1600; NA	1600	120 V	3842559932
Control unit F3200; NA	3200	120 V	3842559933
Hand switch			3842559940

Strut profile 40x40L

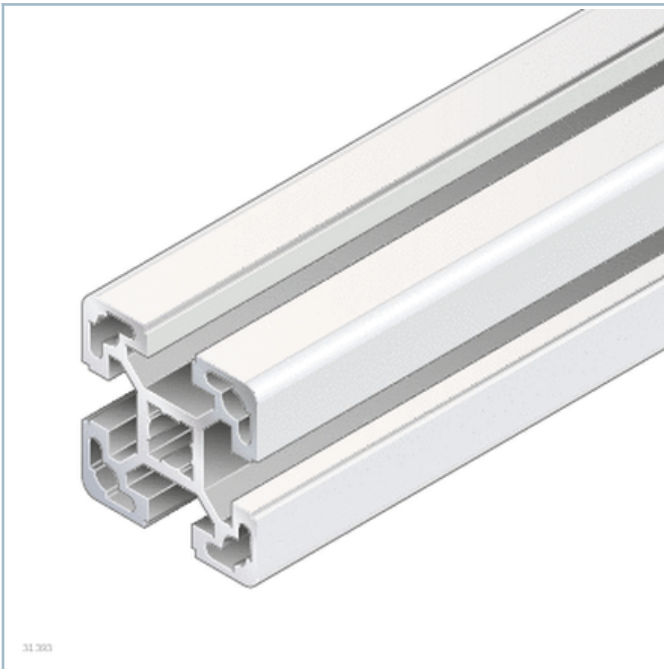

Product description

[Quick & Easy profile finishes](#)

[Introduction to strut profiles](#)

Technical data

[Quick & Easy profile finishes](#)

Dimensions

Strut profile 40x40L

40x40L	
A	= 5,6 cm ²
I _x	= 9,1 cm ⁴
I _y	= 9,1 cm ⁴
W _x	= 4,5 cm ³
W _y	= 4,5 cm ³
I _t	= 1,3 cm ⁴
W _t	= 0,74 cm ³
m	= 1,5 kg/m

19199

Ordering codes

The following caps with holes are needed:



40x40 signal gray (1 item)





40x40 black (1 item)

The following cover caps are needed:

40x40 signal gray (1 item)

40x40 black (1 item)

	L			ESD	No.
	mm				
Strut profile 40x40L	50 ... 6070		1		3842993120
Strut profile 40x40L M12/-	60 ... 6000		1		3842993121
Strut profile 40x40L M12/M12	110 ... 6000		1		3842993122
Strut profile 40x40L M12/D17	90 ... 6000		1		3842993123
Strut profile 40x40L D17/-	60 ... 6000		1		3842993124
Strut profile 40x40L D17/D17	80 ... 6000		1		3842993125
Strut profile 40x40L D17/D17V	80 ... 6000		1		3842993126
Strut profile 40x40L D9,8/D9,8	80 ... 6000		1		3842993129
Strut profile 40x40L, 20xL=6070mm	6070	20			3842529339
Strut profile 40x40L Q&E, L50-6000	50 ... 6070				3842993724
Cover cap 40x40, signal gray			100		3842548746

	L			ESD	No.
	mm				
Cover cap 40x40, black			20		3842548747
Cover cap with hole 40x40, signal gray			20		3842548782
Cover cap with hole 40x40, black			20		3842548783
Strut profile 40x40L	6070		1		3842529340

Quick & Easy profile finishes

Standard profile finishes (note minimum length) ¹⁾	M12 / D9,8 / D17 / DB17 / F1 (A)
Customized profile finishes ($L_{\max} = 5400$ mm) ²⁾	DI / DIS / MT / MTS / MI / MIS / DG

1) For the specified slots

2) $DG_{\max} = 45^\circ$; $L_{\min1} / L_{\min2} = 370 / 440$ mm

Bracket 40/40

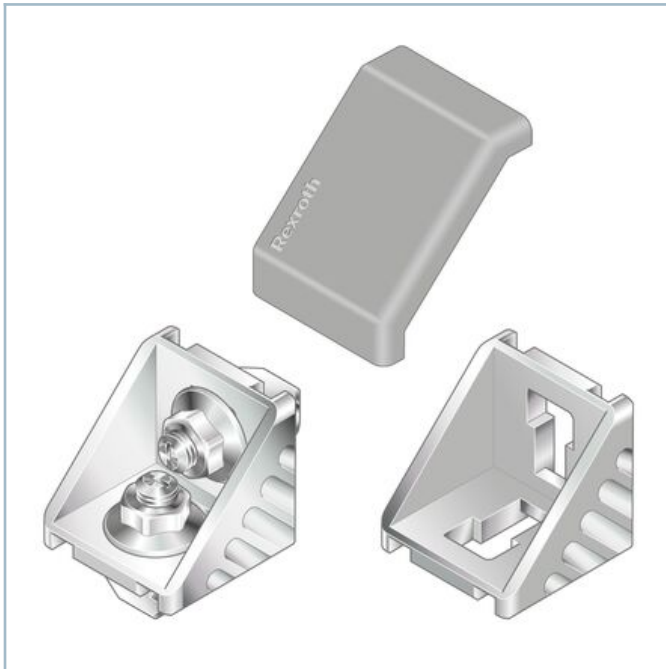
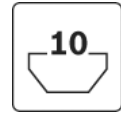



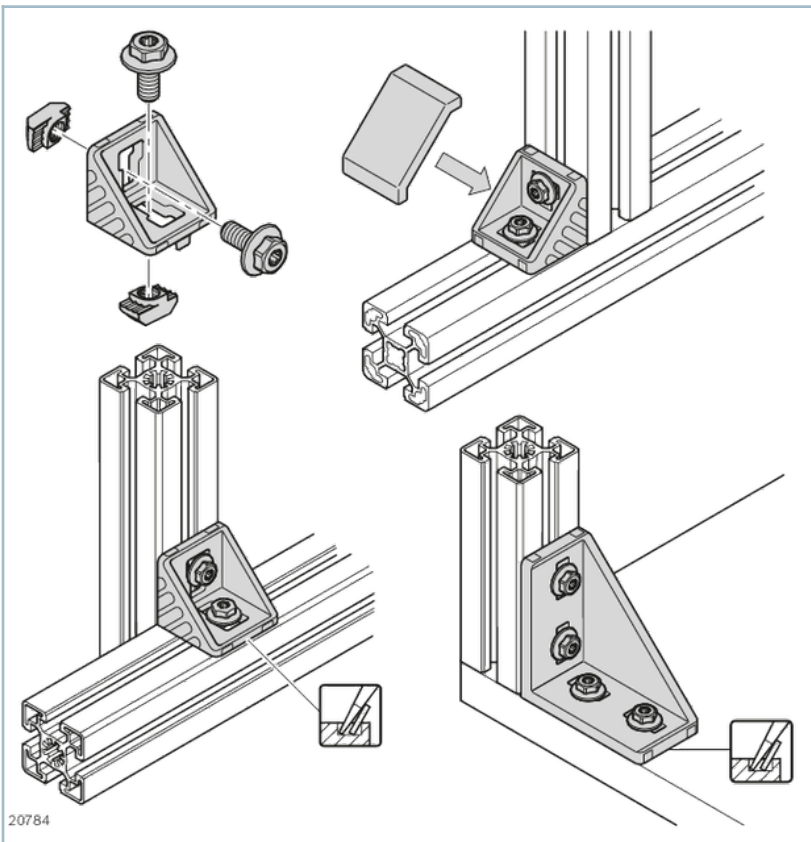
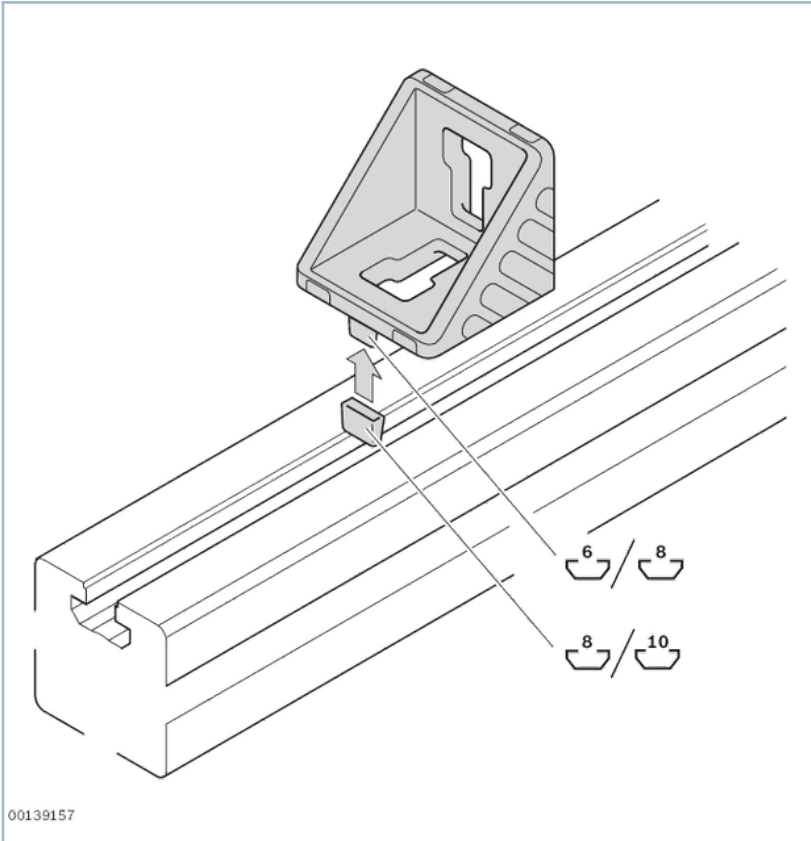

- Brackets with centering lugs for rapid, precise assembly with protection against turning
- Centering lugs can be easily broken off for assembly on plates or at right angles to the slot
- Version *designLINE* with special silver paint (RAL 9006) for an especially high-quality design
- Cover cap to protect from dirt, available in signal gray (RAL 7004) and black ESD (RAL 9005)
- Profile finishing: not required

Product description



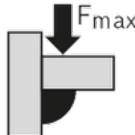
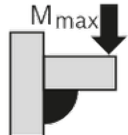
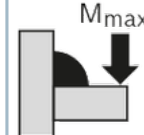

Connection elements, selection criteria

Technical data

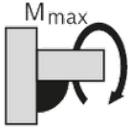
	Groove	ES D	Material entry			
				F_{max}	M_{max}	M_{max}
				N	Nm	Nm
Bracket	10		Bracket: Diecast aluminum, vibratory ground Fastening material: Steel, galvanized	3000	55	145
	10		Bracket <i>designLINE</i> : Diecast aluminum; vibratory ground, painted (RAL 9006) Fastening material: Steel, galvanized	3000	55	145
	10		Bracket: Diecast aluminum, vibratory ground	3000	55	145
Cover cap for bracket			PP			
			PP			

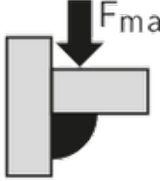
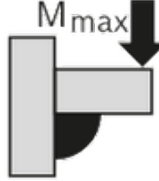
M_{max}
Nm
35
35
35

Typ				
40 / 40	3000 N	55 Nm	145 Nm	35 Nm

Dimensions

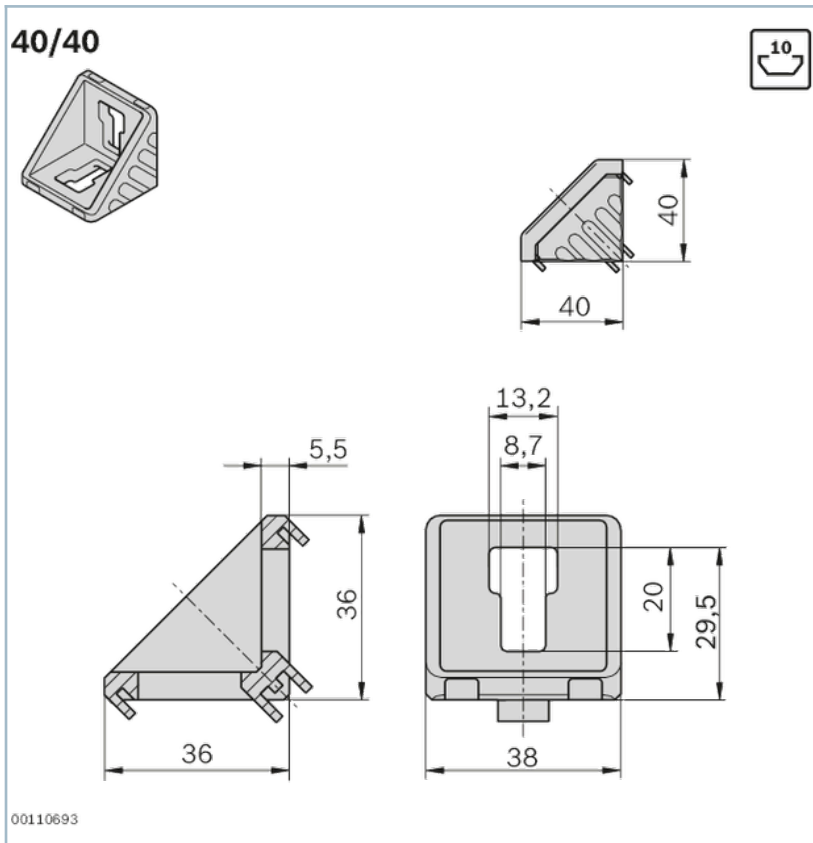

Accessories

Recommended accessories

Cover cap for bracket 40/40, signal gray



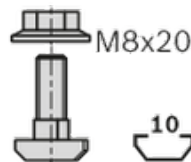

Cover cap for bracket 40/40, black

Delivery notes

FS5



Ordering codes

	Groove		ESD	FS	No.
Bracket 40x40 set (standard)	10			2xFS5	3842529383
Bracket 40x40 set design <i>LINE</i>	10			2xFS5	3842551603
Bracket (standard) 40x40	10	20			3842528967
Cover cap for bracket 40/40, signal gray		100			3842548854
Cover cap for bracket 40/40, black		20			3842548855

Cover cap 40x40

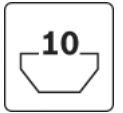

- Cover cap to prevent injuries at open profile ends
- Attractive design
- Cover cap with hole for use with leveling feet and rollers

Product description

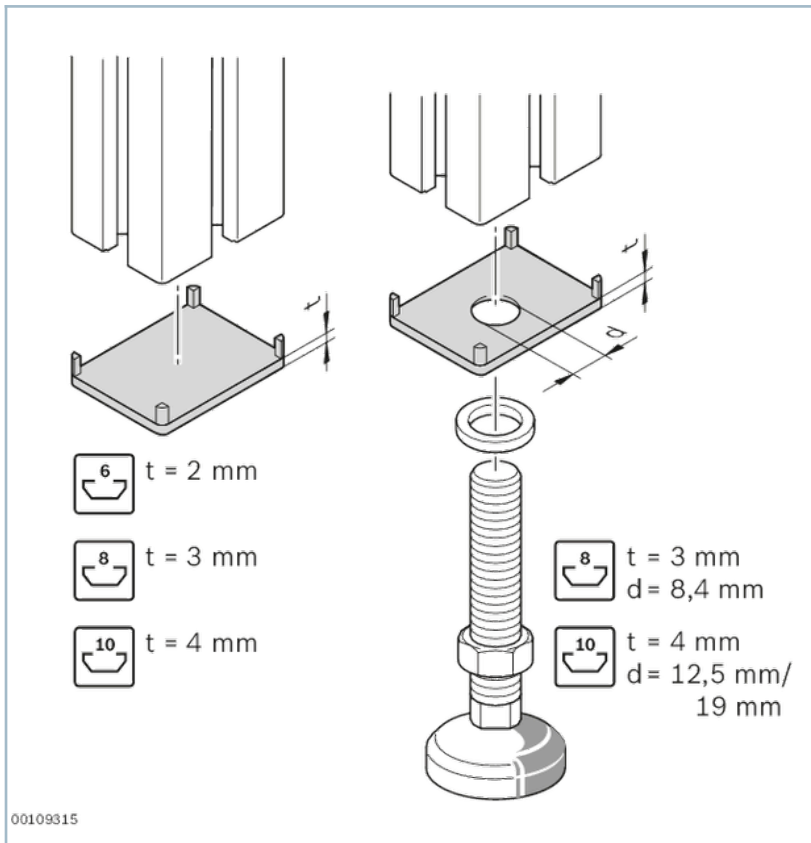



Introduction to strut profiles

Technical data

No.	Material
3842548746	PP
3842548747	
3842548782	
3842548783	

Ordering codes

		ESD	No.
Cover cap 40x40, signal gray	100		3842548746
Cover cap 40x40, black	20		3842548747
Cover cap with hole 40x40, signal gray	20		3842548782
Cover cap with hole 40x40, black	20		3842548783

Oval base plate with screw hole



- Leveling feet for compensating irregularities in the floor up to 10°
 - modular system, various combinations possible
 - spindles and base plates can be combined as desired
 - base plates with screw hole for simple screw fitting to the floor
- Profile finishing: thread M in central hole

Product description

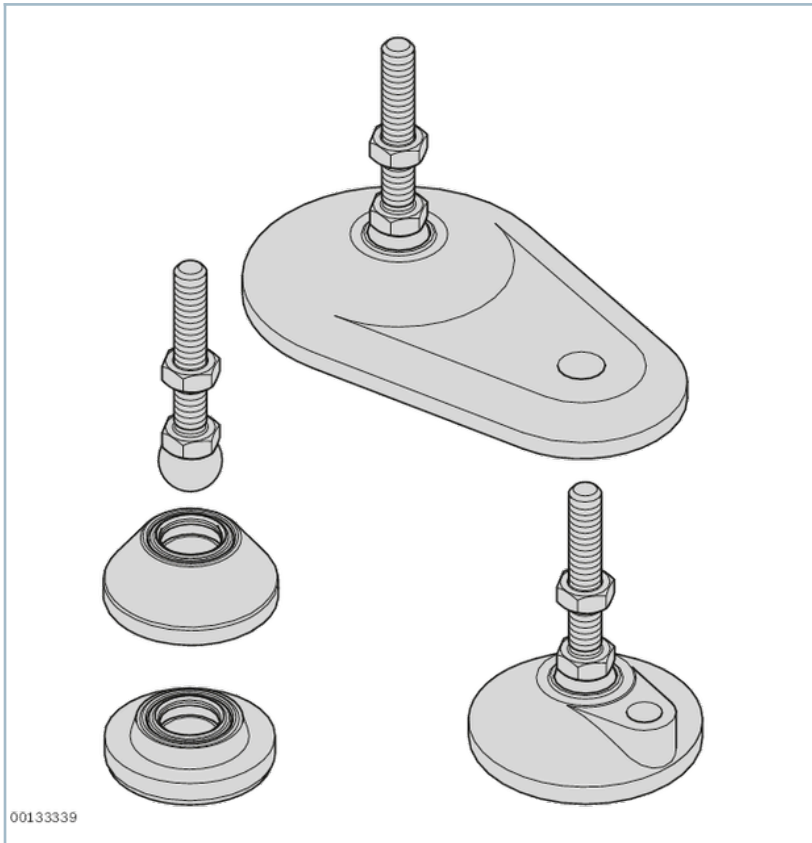

Technical data

Material

Diecast zinc, black powder coating

Accessories



Bearing ring

- For cover caps with hole in the sizes 40x40, 45x45, 50x50 and 60x60
- For M12 threads
- To protect the caps when tightening accessories

Ordering codes

	F	D	a	L		No.
	N	mm	mm	mm		
Oval base plate with screw hole D59	30000	59	52	100	20	3842538679
Oval base plate with screw hole D79	30000	79	65	130	20	3842538680

Spindle

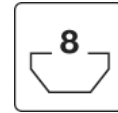
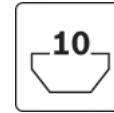

- Leveling feet for compensating irregularities in the floor up to 10°
 - modular system, various combinations possible
 - spindles and base plates can be combined as desired
 - base plates with screw hole for simple screw fitting to the floor
- Profile finishing: thread M in central hole

Product description

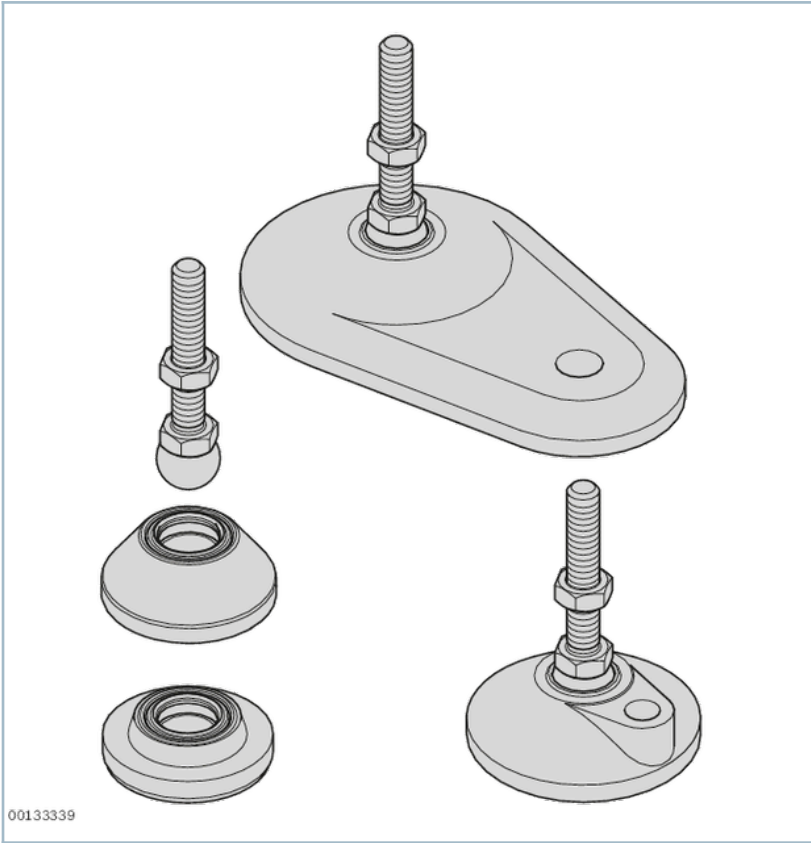

Dimensions

Spindle

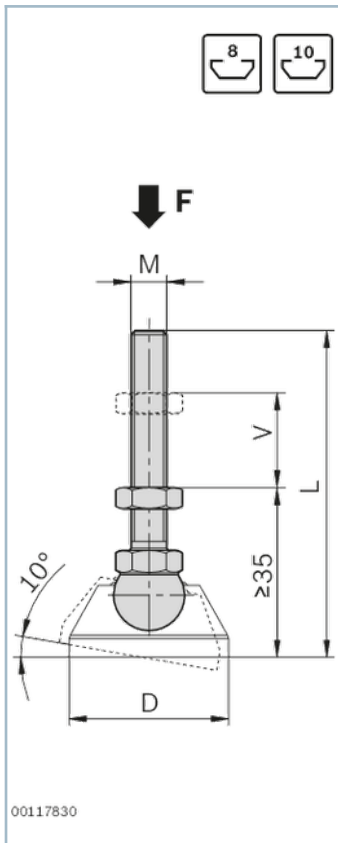















Accessories



Bearing ring

- For cover caps with hole in the sizes 40x40, 45x45, 50x50 and 60x60
- For M12 threads
- To protect the caps when tightening accessories

Ordering codes

	F	M	L	V		ESD	No.
	N		mm	mm			
Leveling foot spindle, stainless steel M8x75	10000	M8	75	20	20		3842536811
Leveling foot spindle, stainless steel M12x85	20000	M12	85	30	20		3842536812
Leveling foot spindle, stainless steel M12x145	20000	M12	145	80	20		3842537223
Leveling foot spindle, stainless steel M12x200	20000	M12	200	135	20		3842537225
Leveling foot spindle, stainless steel M16x85	30000	M16	85	20	20		3842537227
Leveling foot spindle, stainless steel M16x145	30000	M16	145	80	20		3842537229
Leveling foot spindle, stainless steel M16x200	30000	M16	200	135	20		3842537231
Leveling foot spindle, steel; galvanized M8x75	10000	M8	75	20	20		3842537220
Leveling foot spindle, steel; galvanized M12x85	20000	M12	85	30	20		3842537222
Leveling foot spindle, steel; galvanized M12x145	20000	M12	145	80	20		3842537224
Leveling foot spindle, steel; galvanized M12x200	20000	M12	200	135	20		3842537226
Leveling foot spindle, steel; galvanized M16x85	30000	M16	85	20	20		3842537228
Leveling foot spindle, steel; galvanized M16x145	30000	M16	145	80	20		3842537230
Leveling foot spindle, steel; galvanized M16x200	30000	M16	200	135	20		3842537232

Flange nut, T-bolt

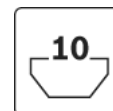

- Secure, conductive connection
- Notch at bolt end as marker for identifying correct position
- Profile finishing: not required

Technical data

	Material
Flange nut 8 mm slot M6	Galvanized steel
Flange nut 10 mm slot M8	
T-bolt M6x16	
T-bolt M6x20	
T-bolt M6x25	
T-bolt M8x20	
T-bolt M8x25	
T-bolt M8x30	
T-bolt M8x40	
T-bolt M8x50	
T-bolt M8x60	
T-bolt M8x45	

Nut	
8	4000 N
10	6000 ... 18000 N ¹⁾

1) Depending on the profile

Dimensions

T-bolt M8x20 and flange nut M8

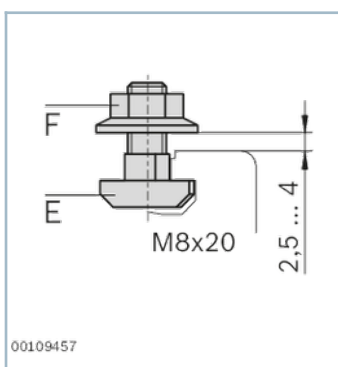

1) E = T-bolt M8x20

2) F = flange nut M8

Flange nut 8 mm slot

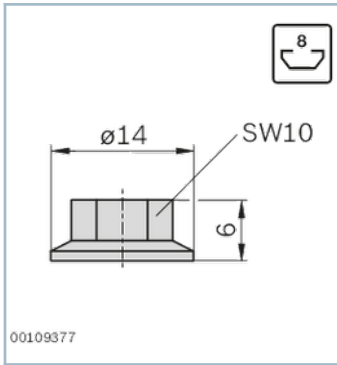



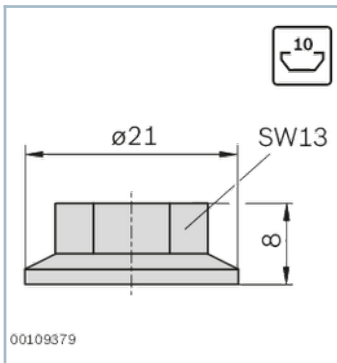

Flange nut 10 mm slot

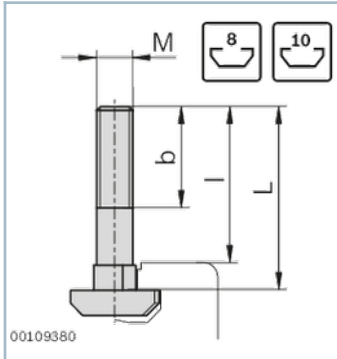









T-bolt



Ordering codes

	Groove	M	b	l		ESD	No.
			mm	mm			
Flange nut 8 mm slot M6	8	M6			100		3842523925
Flange nut 10 mm slot M8	10	M8			100		3842345081
T-bolt M6x16	8	M6x16	10	14	100		3842523920
T-bolt M6x20	8	M6x20	14	18	100		3842523921

	Groove	M	b	l		ESD	No.
			mm	mm			
T-bolt M6x25	8	M6x25	18	23	100		3842523922
T-bolt M8x20	10	M8x20	14	14	100		3842528715
T-bolt M8x25	10	M8x25	19	19	100		3842528718
T-bolt M8x30	10	M8x30	24	24	100		3842528721
T-bolt M8x40	10	M8x40	22	34	100		3842528724
T-bolt M8x50	10	M8x50	22	44	100		3842528727
T-bolt M8x60	10	M8x60	22	54	100		3842528730
T-bolt M8x45	10	M8x45	22	39	100		3842563312

ATTACHMENT E

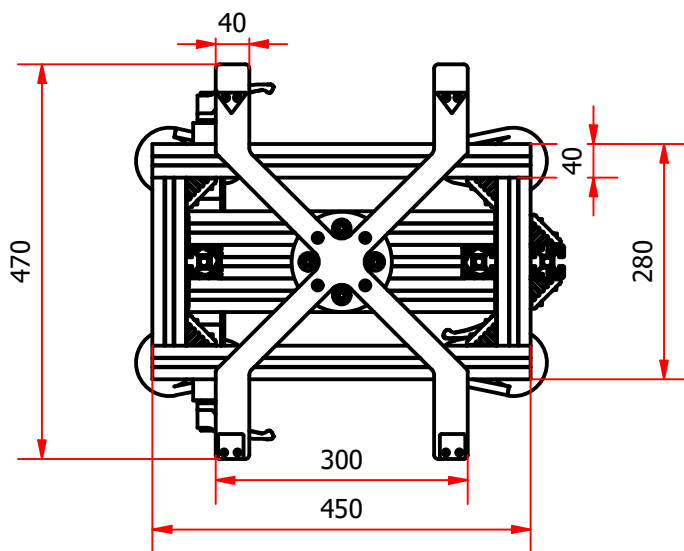
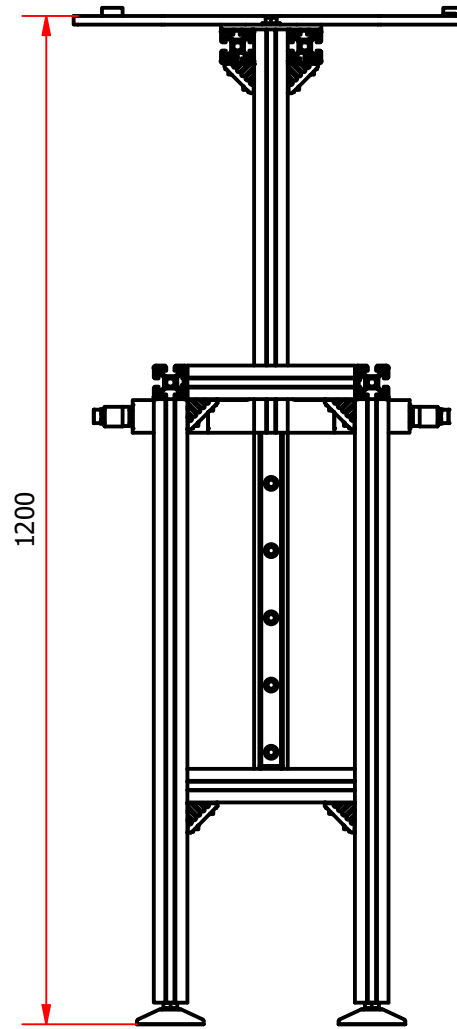
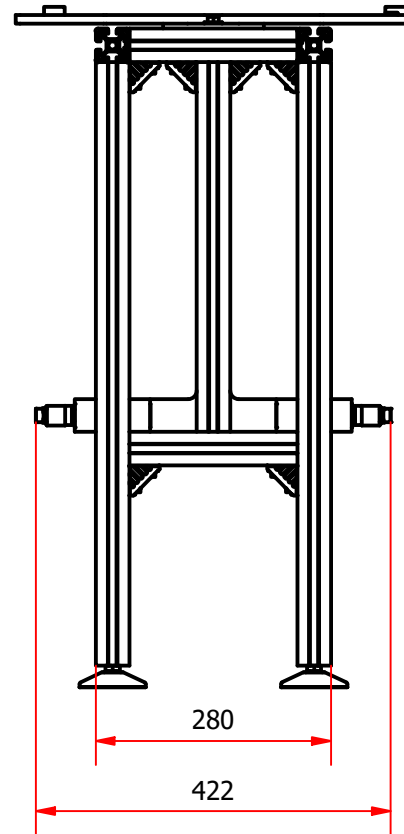
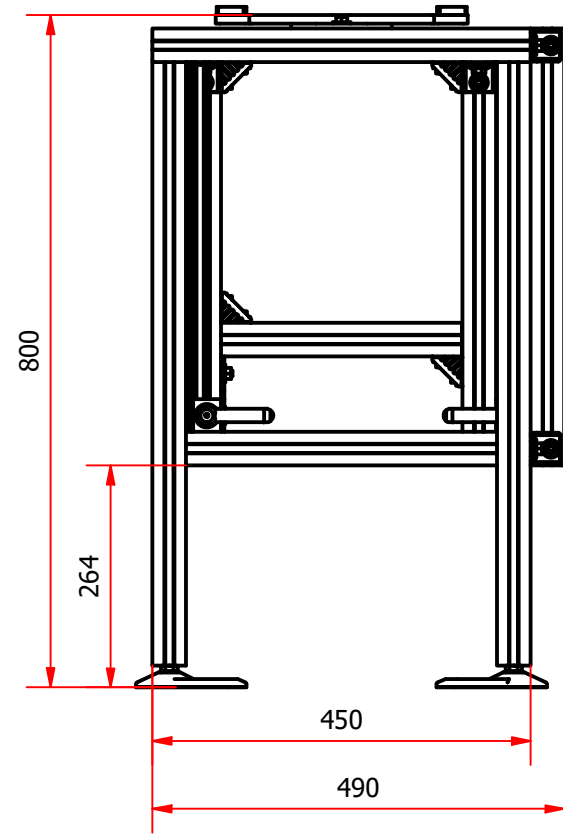

Parts List			
ITEM	QTY	PART NUMBER	DESCRIPTION
1	2	AS12718 Profile L-450	Rexroth 40x40 profile, L=450
2	3	R160570431	Rexroth ball guide rail KSA_030_SNS_N_MA_AK
3	3	R161974282	Rexroth clamping element HK3005
4	2	AS12718 Profile L-370	Rexroth 40x40 profile, L=370
5	4	AS12718 Profile L-718	Rexroth 40x40 profile, L=718
6	2	AS12718 Profile L-287	Rexroth 40x40 profile, L=287
7	4	AS14206 Oval base plate	Oval base plate BR 3 842 538 680
8	4	AS11829 Spindel M12	Rexroth 3 842 537 224
9	4	AS12718 Profile L-200	Rexroth 40x40 profile, L=200
10	28	AS12039 Angle bracket 40x40	Rexroth 40x40 angle bracket assembly
11	1	PL 330x4	Plate LxWxH=330x40x4
12	2	AS12718 Profile L-480	Rexroth 40x40 profile, L=480
13	6	AS12155 Flange nut M8	Rexroth 3 842 345 081
14	6	AS12153 T-Bolt M8x20	Rexroth 3 842 528 715
15	1	BMJ_BinFitmentPlate_v2	LxWxH=470x10
16	4	DIN 6912 - M6 x 10	Cylinder Head Cap Screw
17	1	PL Ø120	Plate Ø120x8
18	2	AS12718 Profile L-365	Rexroth 40x40 profile, L=365
19	1	AS12718 Profile L-520	Rexroth 40x40 profile, L=520

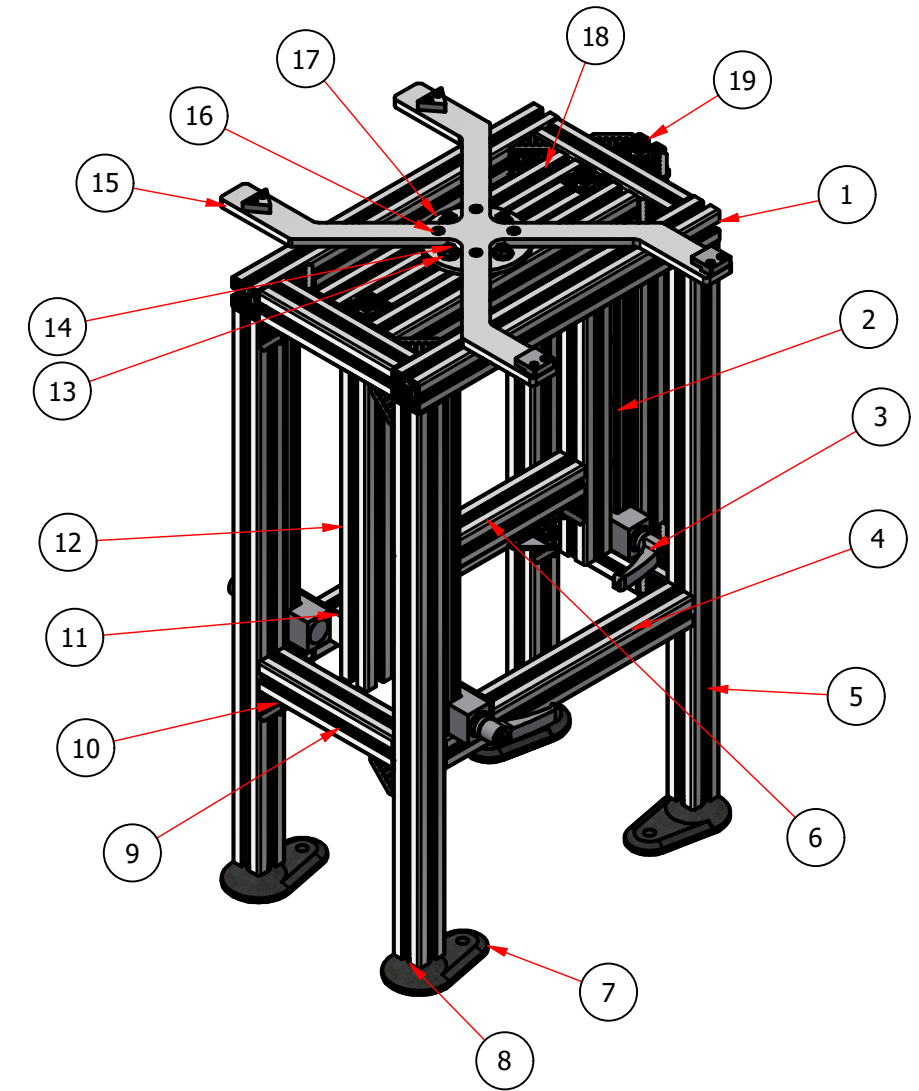

Designed by IB	Date designed 5/7/2023	Approved by UG	Date approved 5/10/2023	Projection 	Sheet size A3
Autostore Technology AS Stokkastrandvegen 85, 5578 Nedre Vats, Norway		Description / Dimension Bin Measuring Jig - Mechanical version		Material Aluminium	
This drawing / document is the property of Autostore Technology AS. The drawing and contents cannot be made public, copied or otherwise used without written consent by Autostore Technology AS.			Filename BMJ_assembly_mechanical.idw	Revision 0	Sheet 1 / 1



University of Tromsø – The Arctic University of Norway
Faculty of Engineering Science and Technology
Department of Computer Science and Computational Engineering

Master of Science

Master thesis topic: Development of a jig for CMM measurements on AutoStore Bins

—
Candidate name: Ida J. T. Bjørhovde
Master thesis in Engineering Design spring 2023

Confidential: Yes



Problem description

Background information

AutoStore

AutoStore is an efficient AS/RS system - Automatic Storage and Retrieval System, made as a dense cube. The density of the system allows the system to quadruple within an existing warehouse without the need for more floor space. The layout of AutoStore can be customized to each customer to fit their needs and available space. However, the system is based on the five standard modules for each system, these are:

- **Grid:** The structure of the cube. Consist of aluminium parts and is built on a flat floor. Keeps the bins in place and have railways for the robots. Available in two configurations, Single-Double Grid (SDG) and Double-Double Grid (DDG).
- **Bins:** The storage units. The bins are stacked on top of each other with a footprint of 649x449 mm. It is possible to subdivide the bin into different compartments. Available in three different heights; 220, 330 & 425 mm.
- **Robots:** The main workers. Drive on top of the grid to dig and collect bins. Three different robots are available: R5, R5+, and B1.
- **Ports:** The workstations. Connected to the grid but stays on the outside. This is where warehouse operators work with order fulfillment and restocking. There are five different ports available: ConveyorPort, CarouselPort, SwingPort, RelayPort, and PickupPort.
- **Controller:** The brain of AutoStore. Controls robot traffic, bin placements, and ports. Keeps track of everything and is easily accessible to service personnel.



Figure 0.1 - AutoStore system

AutoStore Bins

The Bins are made by certified AutoStore bin manufacturers around the world. Due to the shape of the bin, transport costs are high, and therefore AutoStore produces the bins as close as possible to the end customers via production partners. The AutoStore system sets strict requirements for the different modules in the system, including the bins. The bin is designed to be stacked on top of each other inside the grid and is handled by robots and presented in ports. The bins are interacting with all physical modules and has, therefore,

strict production claims. The loading and handling scenarios set high demands in production quality and product performance. The Bins are made of thermoplastics, mainly HDPE or PP-C.

To make sure that the Bin does not exceed its limits, samples of the products are sent to AutoStore's test lab in Nedre Vats/Norway, and they will be taken through different product quality assurance processes. In addition, metrology studies will be performed to observe and measure the Bin sample's condition. The test requirements are set by the functionalities of the AutoStore System.



Figure 0.2 - AutoStore Bins

Problem

CMM setup and challenges

The AutoStore Bins are measured with high-quality CMM equipment for the metrology studies. When samples from Bin production arrive, they are climatized before the studies take part, to have a stable sample since they are made of plastic. The CMM equipment in AutoStore's test lab consists of a non-contact arm with a laser scanner from Hexagon and a



Figure 0.3 - AutoStore test lab equipment

granite table. The requirements for the measurements are defined by the product drawings and an additional specification guideline.

There are a lot of measurements taken around the Bin, and some of these can cause challenges with today's setup. These challenges need to be solved to fulfil AutoStore's own specifications. Today, two different scans are made for each sample, one where the Bin is placed on the table with the bottom on the surface (a-scan) and one where the bin is turned upside down (b-scan). This causes some challenges with some height measurements as well as report generating (two different reports are made) and generates therefore more work than necessary. The optimal result would consist of a solution where all measurements are taken in preferably one scan, generating one report. However, there are challenges with this, and some exceptions can be made.

Problem description

The project shall focus on an optimal solution, where all measurements are measured in one scan. This will reduce the amount of data stored and will be a more efficient way to scan a Bin sample. Preferably an internal jig needs to be made, which can fulfill all related requirements. The internal jig should be designed as a prototype to start with, where adjustments to a final design can be done after testing and verification.

There might be challenges with connecting all measurements in one scan, and therefore, an optimization of today's setup might be an alternative. The optimization shall focus on including all measurements (a smaller jig might be a solution) and generate one report from the two scans.

The equipment and solutions need to be tested and validated before they can be implemented. The research and work done could lead to updates of procedures, guidelines, and/or the scan program itself.

The work shall include:

1. A literature study both in terms of finding state-of-the-art for these types of products and solutions in the market and potential competitors, as well as literature that is necessary to solve the problem (regulations, standards for materials, algorithms etc.).
2. Establishment of some case studies including specifications (i.e., loading and boundary conditions, physical conditions, requirements for stiffness, strength, weight, materials, temperatures).
3. Analytical and numerical analysis of the concept.
4. Suggestions for future work and description of remaining work.

The solution of the task should be based on typical engineering design methods and areas of study for the Master Program Engineering Design at UiT – campus Narvik.

General information

This master thesis should include:

- * Preliminary work/literature study related to actual topic
 - A state-of-the-art investigation
 - An analysis of requirement specifications, definitions, design requirements, given standards or norms, guidelines, and practical experience etc.
 - Description concerning limitations and size of the task/project
 - Estimated time schedule for the project/ thesis
- * Selection & investigation of actual materials
- * Development (creating a model or model concept)
- * Experimental work (planned in the preliminary work/literature study part)
- * Suggestion for future work/development

Limitations of the task/project

There may be information in the report that may not be open, and if so, the report should be restricted. This will be considered before the candidate submits the thesis.

Preliminary work/literature study

After the task description has been distributed to the candidate a preliminary study should be completed within 4 weeks. It should include bullet points 1 and 2 in "The work shall include", and a plan of the progress. The preliminary study may be submitted as a separate report or "natural" incorporated in the main thesis report. A plan of progress and a deviation report (gap report) can be added as an appendix to the thesis.

In any case the preliminary study report/part must be accepted by the supervisor before the student can continue with the rest of the master thesis. In the evaluation of this thesis emphasis will be placed on the thorough documentation of the work performed.

Reporting requirements

The thesis should be submitted as a research report and must include the following parts: Abstract, Introduction, Material & Methods, Results & Discussion, Conclusions, Acknowledgements, Bibliography, References and Appendices. Choices should be well documented with evidence, references, or logical arguments.

The candidate should in this thesis strive to make the report survey-able, testable, accessible, well written, and documented.

Materials which are developed during the project (thesis) such as software/codes or physical equipment are a part of this paper (thesis). Documentation for correct use of such information should be added, as far as possible, to this paper (thesis).

The text for this task should be added as an appendix to the report (thesis).

The report (Abstract, Introduction, Material & Methods, Results & Discussion, Conclusions, Acknowledgements, Bibliography, References) should not exceed 50 pages. Any additional material should be included in the appendix.

General project requirements

If the tasks or the problems are performed in close cooperation with an external company, the candidate should follow the guidelines or other directives given by the management of the company.

The candidate does not have the authority to enter or access external companies' information system, production equipment or likewise. If such should be necessary for solving the task in a satisfactory way a detailed permission should be given by the management in the company before any action are made.

Any travel cost, printing and phone cost must be covered by the candidate themselves, if and only if, this is not covered by an agreement between the candidate and the management in the enterprises.

If the candidate enters some unexpected problems or challenges during the work with the tasks and these will cause changes to the work plan, it should be addressed to the supervisor at the UiT Campus Narvik or the person which is responsible, without any delay in time.

Submission requirements

This thesis should result in a final report with an electronic copy of the report included appendices and necessary software codes, simulations, and calculations. The final report with its appendices will be the basis for the evaluation and grading of the thesis. The report with all materials should be delivered in an electronic format. The report should be in PDF format while the rest of the material should be bundled in ZIP file. A standard front page, which can be found on the UiT Campus Narvik internet site, should be used. Otherwise, refer to the "General guidelines for thesis" and the subject description for master thesis.

The final report with its appendices should be submitted no later than the decided final date. The final report should be delivered/ submitted/ uploaded to WISEflow.

Date of distributing the task: 09.01.2023

Date for submission (deadline): 15.05.2023

Contact information

Supervisors at the UiT Narvik

Annette Meidell

annette.meidell@uit.no

Candidates contact information

Ida J.T. Bjørhovde

ity004@post.uit.no

Schedule

