

Adjectival and Genitival Modification in Definite Noun Phrases in Icelandic

A Tale of Outsiders and Inside Jobs

—
Alexander Peter Pfaff

A dissertation for the degree of Philosophiae Doctor – April 2015

Adjectival and Genitival Modification in Definite Noun Phrases in Icelandic

—

A Tale of Outsiders and Inside Jobs

A thesis submitted for the degree Philosophiae Doctor

University of Tromsø
Faculty of Humanities, Social Sciences and Education
Center for Advanced Study in Theoretical Linguistics (CASTL)
April 2015

Contents

Acknowledgments	vii
1 Introduction	1
1.1 The DP Analysis and its Repercussions	3
1.1.1 Refining the DP Structure	4
1.1.2 Layers in the Noun Phrase	6
1.1.3 Modifiers, N Movement, and Classes of Adjectives	7
1.2 More on Adjectives	10
1.2.1 (NON-) Intersectivity, Predicativity, Restrictivity	10
1.2.2 Predicativity and Adjectives as Reduced Relative Clauses	14
1.2.3 Cinque (2010)	17
1.3 The Position(s) of Possessives and Genitives in the DP	19
1.4 The Data	21
1.5 Road Map	21
I Adjectives and the Icelandic Article System	25
2 Articles, Patterns and Adjectival Inflection	29
2.1 The Definite Article(s)	31
2.1.1 ART and DEF	31
2.1.2 Literary Icelandic? – Pattern (II)	35
2.1.3 Ignored, but Alive and Kicking – Pattern (III)	38
2.1.4 One Article or Two?	42
2.1.5 The Missing Link (Pfaff 2007, 2009)	46
2.1.6 Core Assumptions	48
2.2 Adjectival Inflection	50
2.2.1 Distribution	52
2.2.2 Adjectival Inflection – Morphology or Semantics?	53
2.2.3 Inside and Outside <i>articleP</i>	55

3	Strong Adjectives: Pattern (IV)	59
3.1	Appositive Adjectives	60
3.1.1	Absence of Restrictivity	61
3.1.2	Adverbiality and Freedom from Attitude	65
3.1.3	Temporal/Anaphoric (In-) Dependence	67
3.1.4	Reduced Relative Clauses	70
3.2	Potts' <i>Logic of Conventional Implicatures</i>	74
3.2.1	'Not at-issue' meaning	75
3.2.2	Appositives	76
3.2.3	Expressives	78
3.3	More Evidence	80
3.3.1	Positional Predicates	80
3.3.2	Little Partitives	82
3.4	Summary	88
4	The Weak Patterns	91
4.1	Properties of the Weak Patterns	92
4.1.1	"Mixed" Patterns (I)+(III)	92
4.1.2	(Non-) Restrictivity?	96
4.1.3	Non-Referentiality and Uniqueness	100
4.2	The Three Zones for Weak Adjectives	104
4.2.1	Thematic and Predicative Readings of Nationality Adjectives	104
4.2.2	The Minimal Nominal Domain: nP	112
4.2.3	Update: Another Zone above nP	115
4.2.4	A Fresh Look at Patterns	118
4.3	The Index Phrase	119
4.3.1	The Referential Index	120
4.3.2	Interpretation of the Index	121
4.3.3	<i>i</i> xP Movement and the Decomposition of the Article	122
4.3.4	The Shape of Trees to Grow	125
4.3.5	An Extra Restriction on the Free Article	128
4.4	Loose Ends	133
4.4.1	Indirect Modification?	133
4.4.2	Non-At-Issue Content?	136
4.5	Summary	137

Summary Part I	141
II Genitivals, Possession and Relations	145
5 Possession: Some Basic Facts	149
5.1 Background	149
5.1.1 Structural Positions of GENITIVALS	150
5.1.2 GENITIVALS, Head Nouns and Relations	151
5.2 Possessive Constructions in Icelandic	153
5.2.1 Formal Properties of <i>Pronominal Possessives</i>	154
5.2.2 Pronominal Possessive Positions	156
5.2.3 The Position of DP-Genitives	160
5.2.4 POSS1 Revisited	163
5.3 Previous Analyses	165
6 Possession and Definiteness Marking	173
6.1 Possession and Adjectival Inflection	173
6.1.1 (In-) Definiteness and Possession	180
6.2 Pronominal Possessives and DEF	185
6.3 DP-Genitives and DEF	198
6.3.1 A Note on the Proprial Article	202
6.4 An Analysis of Poss1	207
6.4.1 High Possessives	207
6.4.2 Prenominal Pronominal Possessives	209
6.5 APPENDIX – Variation: “Definite” Adjectives?	219
7 The Genitive’s Problem	223
7.1 Low GENITIVALS and Stranded Genitives	223
7.2 POSS2 Revisited	228
7.2.1 SoS – Two Nominal Fseqs (Adger 2013)	228
7.2.2 Challenges for SoS	233
7.3 \mathfrak{N} -Structures	236
7.3.1 Extractability and <i>i</i> \mathfrak{X} P-Movement	238
7.3.2 Inside and Outside the Index Phrase	239
7.3.3 Sizes	242
7.3.4 Anchoring	243
7.3.5 Open Issues	245
7.4 Summary	250

Summary Part II	251
8 General Overview and Outlook	255
8.1 Zones	256
8.2 Adjectival Semantics	259
8.3 Possession	261
8.4 Beyond Icelandic?	263

Acknowledgments

I'm running out of ink!!! ... as the famous philosopher used to say, and these words of wisdom have never been more true than now in the final moments of the creative process known to the expert as *writing a thesis*. Of course, strictly speaking, I am running out of time, patience, energy, money, motivation, inspiration and many more things, but curiously, the only thing one does not run out of so easily these days is ink. But be that as it may. We should be grateful that the ink lasted while it did; I know I am. Therefore I would like to seize the opportunity to express my gratitude to everybody involved in the process one way or another. Unavoidably, words will not do justice to a proper assessment of the input and support I have received in the process, which is why I will be brief; blame it on the ink.

First and foremost, I would like to thank my supervisor Gillian Ramchand for intense supervision, for her invaluable input and precious advice, and for changing the way I look at syntax and semantics. Without Gillian, my thesis would look considerably different, and several breakthroughs would not have taken place. Even though I occasionally got lost in details, she never lost sight of the big picture. But I would also like to thank her for her patience over the years. Interestingly, I have turned out to be one of the most stubborn teammates I have ever had the pleasure of writing a thesis with, and I am pretty sure that she must have had the same impression.

Likewise, I would like to thank my second supervisor Peter Svenonius for many in-depth discussions on all kinds of topics and languages, for reading and commenting on some previous chapter drafts.

More generally, I would like to thank CASTL for giving me the opportunity to write this thesis in the first place. It has been an inspiring and rewarding experience – not least thanks to the CASTL community at large. In particular, I would like to thank Antonio Fábregas (especially for numerous conversations about one of the most fascinating linguistic creatures alive: the adjective), Björn Lundquist, Sebastian Bican, Serge Minor, Thomas McFadden and Øystein Vangsnes for many discussions on all sorts of relevant topics, even after office hours. In addition, I would like to thank Marta Velnić and Natalia Mitrofanova for teatime with adjec-

tives.

I would also like to express my gratitude to David Adger for being interested in my work, reading the close-to-final version of this thesis, and challenging it in a mock defense. On that occasion, he provided numerous valuable comments and pointed out several shortcomings, which was very insightful and made me see some problems more clearly. Of course, I especially appreciate his appreciating my \mathfrak{N} structures (see chapter 7). Unfortunately, I haven't been able to implement all his suggestions in the nick of time (the ink, you know). In this context, I also thank the Norwegian National PhD School in Linguistics and Philology for providing funding for said event.

Special thanks, of course, to all my fellow students, colleagues, office mates, corridor mates and campus mates ... Anastasia Makarova, Anna Endresen, Anna Wolleb, Antonio Fábregas, Arlanda Moreno, Björn Lundquist, Éva Dékány, Inna Tolskaya, Kaori Takamine, Madeleine Halmøy, Marina Pantcheva, Marleen van de Vate, Marta Velnić, Martin Krämer, Monika Bader, Natalia Mitrofanova, Olga Urek, Pavel Caha, Rosmin Mathew, Sandhya Sundaresan, Sandra Ronai, Sebastian Bican, Sergey Minor, Tammer Castro, Thomas McFadden, Violeta Martínez-Paricio ... thank you for a great time here in Tromsø; thanks a lot for all those activities involving adjectives, beer, blitz chess, board game(s), chess, dancing, fresh air, hand stands, long (and not so long) conversations, more beer, ping pong ... and other items of philosophical interest. Out-of-the-ordinary thanks go to Sandhya for hitting me whenever the need arose, and even when nobody asked for it; I really appreciate it.

For discussing with me one or several technical aspects of one of the most fascinating noun phrases ever, I would like to thank Einar Freyr Sigurðsson, Eiríkur Rögnvaldsson, Gísli Rúnar Harðarson, Höskuldur Práinsson, Jim Wood, Jóhannes Gísli Jónsson, Þórhallur “Tolli” Eypórsson, and Øystein Vangsnes – þakka ykkur kærlega.

Originally, the subtitle of this thesis was going to be “How to torture Icelanders with yellow cars?” owing to the fact that, in the course of several years, I have put many Icelandic friends, acquaintances, co-workers and teachers through an ordeal that presumably goes against the Geneva convention on judgment tasks. I apologize, and I'm really grateful for your patience in answering strange questions about *the yellow car*, *the French president*, *the perfect crime* and all those examples that are better passed over in silence.

I would especially like to thank Berglind Prunner Rósudóttir, Einar Freyr Sigurðsson, Elías Ingi Björgvinsson, Hildur Sigurðardóttir, Jón Karl Stefansson, Kolfinna Jónatansdóttir, Sigrún Sól Ólafsdóttir for their support and for many intense

and sometimes rather lively discussions of strange Icelandic examples over the years. Kærar þakkir! Ég kann virkilega að meta það.

For discussing Icelandic data with me on one or several occasions, I would furthermore like to thank Ásta Svavarsdóttir, Auður Stefánsdóttir, Brynja Gunnarsdóttir, Brynja Grétarsdóttir, Eiríkur Rögnvaldsson, Gísli Rúnar Harðarson, Guðný Valberg, Guðrún Helgadóttir, Hafdis Ásgeirsdóttir, Haraldur Bernharðsson, Helgi Skuli Kjartansson, Hlíf Árnadóttir, Höskuldur Þráinsson, Inga Júlía Ólafsdóttir, Jóhannes Gísli Jónsson, Kristján Árnason, María Anna Garðarsdóttir, Nanna Hauksdóttir, Rósa Björg Helgadóttir, Rósa Siemsen, Rósa Þorsteinsdóttir, Sigríður Sigurjónsdóttir, Sigríður Sæunn Sigurðardóttir, Sigríður Þorvaldsdóttir, Sigurbörg Fríða Ólafsdóttir, Soffía Auður Birgisdóttir, Solla Graham-Parker, Þórhallur Eypórsson, and Vilberg Ingi Hedinsson. Moreover, I would like to thank those several hundred (anonymous) participants in my survey conducted autumn 2012.

⇒ Hinar innilegustu þakkir ykkur öllum!!!

Last but not least, I would like to thank my family – Lina, Paty, Siglinde and Lambert – for moral support and their patience. Special thanks to my parents without whose valuable contribution this thesis would never have been written.

Chapter 1

Introduction

In simple unmodified definite noun phrases in Icelandic, definiteness is encoded in the so-called suffixed article, while indefiniteness is not morphologically marked at all:

- | | | |
|-----|------------------------------|----------------------------|
| (1) | a. bíll - inn
car - the | c. bíll
car (= 'a car') |
| | b. bílar - nir
cars - the | d. bílar
cars |

When modified, indefinite noun phrases display basically one pattern with all modifiers occurring in prenominal position:

- | | | |
|-----|---|---------------------------------------|
| (2) | a. rauður bíll
red car (= 'a red car') | b. fimm rauðir bílar
five red cars |
|-----|---|---------------------------------------|

Thus, at least from a descriptive point of view, there is a sense in which unmodified and indefinite noun phrases are “boring”. Definite modified noun phrases, on the other hand, display a great variety of patterns a small sample of which is given below:

- | | | |
|-----|---|---|
| (3) | a. rauð.i bíll - inn
red.WK car - the | d. bölvað.ur bíll - inn
bloody.STR car - the |
| | b. hinn fullkomni bíll
the perfect car | e. hinar sjö frjálsu listir
the seven liberal arts |
| | c. leikari - nn frægi
actor - the famous | f. rauðu bílar - nir fimm
red cars - the five |

These examples feature, most prominently, two sets of adjectival inflection, cf. (3a) vs. (3d), a second definite article, viz. the so-called free article, cf. (3b/e),

and both pre- and postnominal modifiers, cf. (3c/f). The full range of those patterns is introduced in a more systematic fashion in the following chapters. If we add possessive modifiers, this variety multiplies even further:

- (4)
- | | |
|---|--|
| <p>a. rauð.i bíll - inn minn
red.WK car - the my</p> <p>b. afi minn sálugi
grandfather my deceased</p> <p>c. þín hetjulega barátta
your heroic battle</p> | <p>d. elskuleg. systir mín
loveable.STR sister my</p> <p>e. hinn raunverulegi faðir hans
the real father his</p> <p>f. hennar hluti hans
her part his
(= 'her part of it')</p> |
|---|--|

It should be obvious that, simply from a descriptive point of view, it is in and of itself a promising enterprise to scrutinize this variety in great detail. Moreover, a close examination of these various patterns also provides valuable and subtle insights into the semantics of modification, and highlights structural aspects not observable in unmodified or indefinite noun phrases. Most of these diversities are only found in Icelandic, which, in turn, means that Icelandic can provide insights that are not immediately inferable from other languages. Therefore, more broadly speaking, Icelandic is a good testing ground for better understanding noun phrase structure and the morpho-semantics of definiteness and modification.

Part I of this thesis addresses adjectival (and numeral) modifiers, while part II is concerned with possessive modifiers and genitives. One central claim of the thesis invokes the revival of an actually old idea, namely that the two definite articles we find on the surface are two manifestations of one and the same underlying element. The suffixed article is the result of movement of a phrasal nominal constituent to a higher position. This assumption allows us to give a straightforward account of all the adjectival patterns, numerals and most possessives. DP-genitives, however, pose a serious challenge. In certain cases, a nominal constituent may move to the high pre-articular position, which yields the suffixed article, while the genitive gets stranded, cf. (5a). Given the specific assumptions I develop in the course of the thesis, the genitive is predicted to move along as a part of the nominal constituent, which results in ungrammaticality, cf. (5b)

- (5)
- | |
|--|
| <p>a. [rauðu bílar] - nír þrír rauðu bílar hans Jóns
red cars - DEF three [he Jón]-GEN
'Jón's three red cars'</p> <p>b. *[rauðu bílar hans Jóns] - nír þrír rauðu bílar hans Jóns-
red cars [he Jón]-GEN - DEF three</p> |
|--|

I will show (in part II) that, with a minor architectural adjustment, this obstacle can be overcome, and that my assumptions suffice to really account for *all* the attested patterns in a simple and straightforward fashion.

In this chapter, I will set the stage for the discussion to come. Before expounding the specific claims made in this thesis in section 1.5, I will give a rather brief summary of central aspects of the nominal projection, adjectival modification, and possessives/genitives. Furthermore, I will briefly comment on the data used in this thesis in section 1.4.

1.1 The DP Analysis and its Repercussions

The DP Analysis is the idea that the constituent traditionally labeled *noun phrase* is not, in fact, headed by the lexical category N^0 as previously thought, but by a functional category D^0 , which, in turn, embeds the lexical NP;¹ compare:

(6) Traditional Analysis:

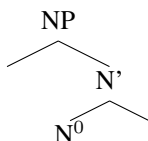

~

(7) DP Analysis:

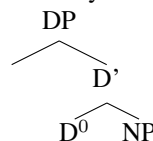

The D slot is assumed to be reserved for a closed class of functional elements, notably (definite) articles and other determiners. Since this idea was introduced into the discourse, most prominently by Abney (1986, 1987),² it has been widely accepted and fruitfully applied to exploring various issues such as the parallel between nominal and clausal structure, semantic properties of noun phrases, and adjectival modification. In the course of the past 30 years or so, several aspects of the original DP analysis have been modified and refined in accordance with general developments in linguistic theory (especially *Cartography*), and more functional categories/projections have been proposed above and inside the lexical NP. This has resulted in rather elaborate and complex architectural models for noun phrase

¹In the discussion, the label 'NP' will be used exclusively for the immediate (maximal) projection of N^0 , whereas 'noun phrase' will be used to capture any relevant extended projection of N (in the sense of Grimshaw 1991).

²The general idea is also found in Brame (1982); Hellan (1986); Fukui (1986); Szabolcsi (1987); moreover, certain aspects of the DP analysis can be traced back to Postal (1966) who argued that pronouns are a species of definite articles (that combine with a null noun) on account of both contributing definiteness to the overall noun phrase.

structure; for a comprehensive overview, see Alexiadou et al. (2007).

1.1.1 Refining the DP Structure

Abney (1986, 1987) and Fukui (1986) propose that D is an INFL-like element, and hence, that DP is a functional projection analogous to IP (or TP, in current terminology):

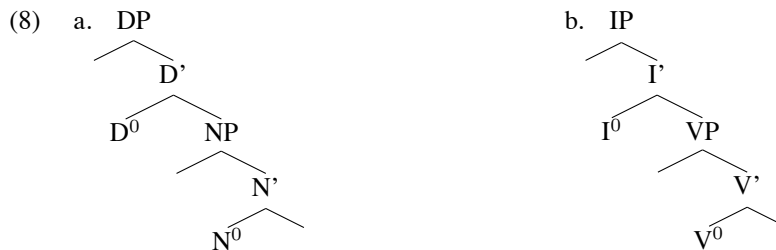

More recently, however, the view has prevailed that DP corresponds to CP, rather than to TP, and that there is a separate projection below D^0 that does correspond to TP (more on that projection in section 1.3):

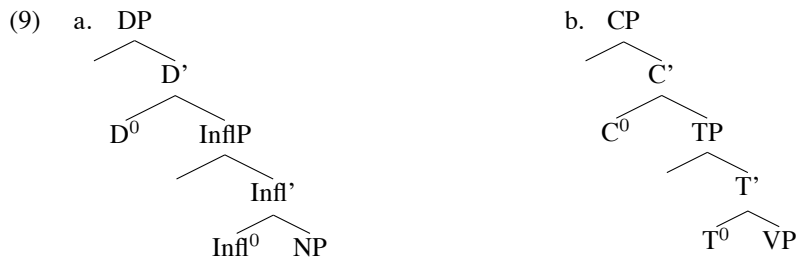

The DP-CP analogy is, on the one hand, based on the status of “articles as complementizers” (Szabolcsi 1994:179). Both complementizers and determiners are assumed to turn their respective complement into an argument, CP and DP. Likewise, both are assumed to anchor or relate the denotation of their complements – propositions and individuals, respectively – to the discourse. On the other hand, parallels between Spec-CP and Spec-DP have been pointed out, the common denominator being that both are A' positions and have Information Structure (IS) related functions. So Spec-DP has been argued to be the target of a number of operations such as (DP-internal) wh-movement, focalization and topicalization.³

³In addition, it has been observed that Spec-DP can serve as an escape hatch for extraction out of the noun phrase for wh-words in Greek and dative possessors in Hungarian, cf. Horrocks and Stavrou (1987); Szabolcsi (1987, 1994); see also (Alexiadou et al. 2007:130-6).

More specifically, it has been proposed that DP be decomposed in a manner similar to Rizzi's (1997) analysis of CP. That is, instead of one single DP projection, we have an articulated fine structure involving several functional projections related to IS (Giusti 1996), and/or definiteness and specificity (Ihsane and Puskás 2001). In other words, we observe a tendency to construe DP as a layer of functional projections, rather than a single projection:



Other functional projections above DP (but within the same nominal projection) have been proposed. Julien (2002, 2005a) proposes (contra Brugé 1996) that there is DemP above DP that hosts demonstratives (see also Pfaff 2009; Adger 2013). Sigurðsson (1993) and Vangsnes (1999a) assume a QP on top of DP (also Giusti and Leko 2005) that hosts (strong) existential and universal quantifiers. Finally, a number of researchers assume that, on the very top of the extended nominal projection, there is a KP, which is the locus of syntactic case and/or may be headed by a case assigning preposition, for instance Vangsnes (1999a,b, 2004);⁴ Svenonius (2006, 2010); Adger (2013). Thus we can observe another inflation of DP towards something like (11):

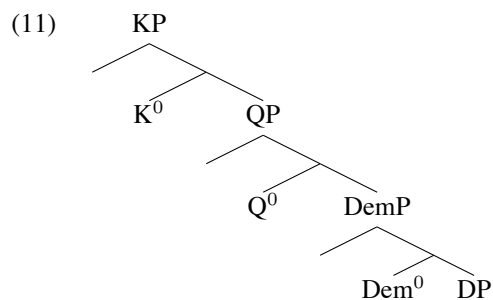

In the same vein, the field between D⁰ and NP has been re-analysed in a successively more fine-grained manner with functional projections postulated for all kinds of modifiers and inflectional features assumed to occur in that space.

⁴Actually, (Vangsnes 1999a:27/8) explicitly identifies QP and KP.

1.1.2 Layers in the Noun Phrase

More broadly speaking, the noun phrase is commonly conceived of as a layered structure rather than merely a sequence of (functional) projections:⁵

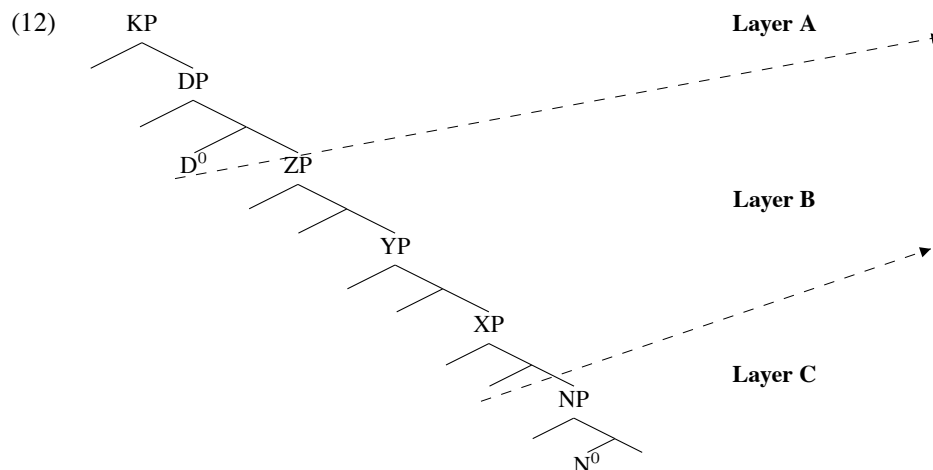

On a typical construal (cf. for instance Giusti 2005:11), A, B, C represent the *Complementation layer* (case, reference), the *Inflectional layer* (agreement/noun-adjective feature sharing; genitive case assignment), and the *Lexical layer* (theta-role assignment), respectively.⁶

This view puts a strong emphasis on a (morpho-) syntactic characterization of the individual layers, and while it is widely accepted, there are subtly different perspectives and various other kinds of layerings have been proposed, for instance:

- (13) a. **relational/categorial** >> **extensional** >> **intensional**
 [KP [DP [CardP [nP [αP [anaP [WP [NP
 (Vangsnes 2004)
- b. **linking** >> **anchoring** >> **point-of-view** >> **classification**
 [KP [DP [PhiP [nP
 (Wiltschko 2014)

⁵The labels X, Y and Z in (12) are placeholders for an unspecified number of functional heads between NP and D⁰ typically assumed to host various modifiers, see next subsection.

⁶*Theta-role assignment* means that a number of (possessor) arguments of the head noun, typically assumed to be generated in Spec-NP (or Spec-nP), are licensed in that layer. This assumption often goes hand in hand with the notion that the possessor subsequently raises to a position in the Inflectional layer in order to receive (structural) genitive case just as the subject argument is assumed to raise from Spec-vP to Spec-TP in order to receive (structural) nominative case (cf. the trees in (9); more on possessors and genitives in section 1.3).

In particular, we find proposals where the respective layers are primarily defined semantically, such that each layer introduces or determines a specific semantic property of the noun phrase:

- (14) a. **quantificational/referential** >> **predicative** >> **kind-denoting**
 [SDP_e [PDP_{<e,t>} [KIP_e ... [NP
 (Zamparelli 2000)
- b. **reference** >> **quantity** >> **mass/count**
 [D [# [Cl [N
 (Borer 2005)

The general rationale behind layered structures is that nominal projections of different sizes denote different entities; semantic properties of noun phrases are defined structurally in terms of layers. Ramchand and Svenonius (2014) conceive of such semantically defined layers or zones as *sortal domains*. For the clause, they assume the domains of events, situations and propositions, respectively; in each domain, a different sort of entity is defined and can be manipulated. Those domains are introduced/closed off by certain designated functional heads: Asp* marks the transition from the domain of events to the domain of situations, and Fin* marks the transition from the domain of situations to the domain of propositions. If we apply this idea to the nominal projection, we can conceive of (14) as dividing the noun phrase into sortal domains, for instance the domain of conceptual/mereological units, the domain of (Carlsonian) kinds, the domain of individuals, the domain of referential expressions, and possibly others.

1.1.3 Modifiers, N Movement, and Classes of Adjectives

(Abney 1987:216) suggests that “quantifiers, like descriptive adjectives, appear on the path that leads from DP to N” (where “quantifiers” actually only covers the class of cardinal (weak) quantifiers like numerals and ‘many’, ‘several’ etc.). The suggestion that adjectives and numerals appear on a “path” means that they are merged along the main projection line in the nominal extended projection. Abney proposes, in particular, that both are merged as heads (A⁰ and Q⁰, respectively) along that path and have very specific selectional properties: A⁰ selects NP or AP, Q⁰ selects AP, or NP, and D⁰ selects AP, QP or NP:⁷

⁷Construing these modifiers as heads along the main projection line has the decisive advantage over previous proposals (in particular Jackendoff 1977) that scope relations can be expressed structurally, cf. (Abney 1987:205). Moreover, selection systematically guarantees the ordering DET >> NUM >> ADJ >> N, which Cinque (2005), elaborating on Greenberg’s Universal 20 (Greenberg 1963), argues is the general base ordering of those elements.

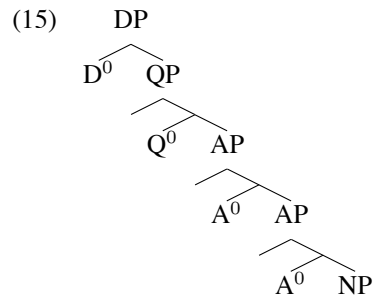

In more recent approaches, there has been a strong tendency to re-interpret Abney's original proposal in terms of functional projections. On this conception, modifiers themselves are not merged as (lexical) heads along the main projection line, but occur in the specifier position of designated functional projections (especially Cinque 1994, 2005, 2010; see also Cinque 1999 on adverbs). A version of (15) updated in this way will look like this:

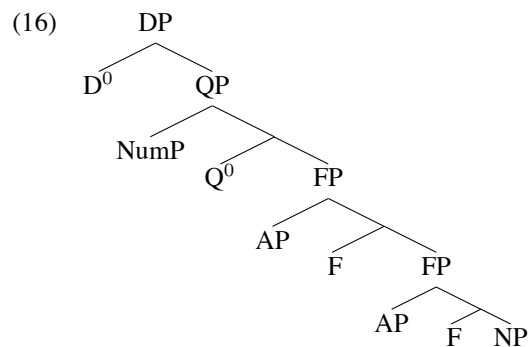

Functional projections of this kind have been invoked on various (morpho-) syntactic and semantic grounds. Two prominent applications involve DP-internal word order variation and adjective ordering restrictions (AORs).

Cinque (1994) argues that the base position of adjectives in Romance and Germanic is uniformly to the left of N. While this is, by and large, the constellation that surfaces in languages like English, many adjectives in Romance languages like Italian typically occur postnominally, i.e. to the right of N:

- (17) a. D ADJ₃ ADJ₂ ADJ₁ N *English*
 the only possible Italian **invasion** of Albania
- b. D ADJ₃ ADJ₂ N ADJ₁ *Italian*
 la sola possibile **invasione** italiana dell' Albania

On Cinque's account, this difference is attributed to partial raising of N⁰ in Italian, whereas N⁰ remains in its base position in English:

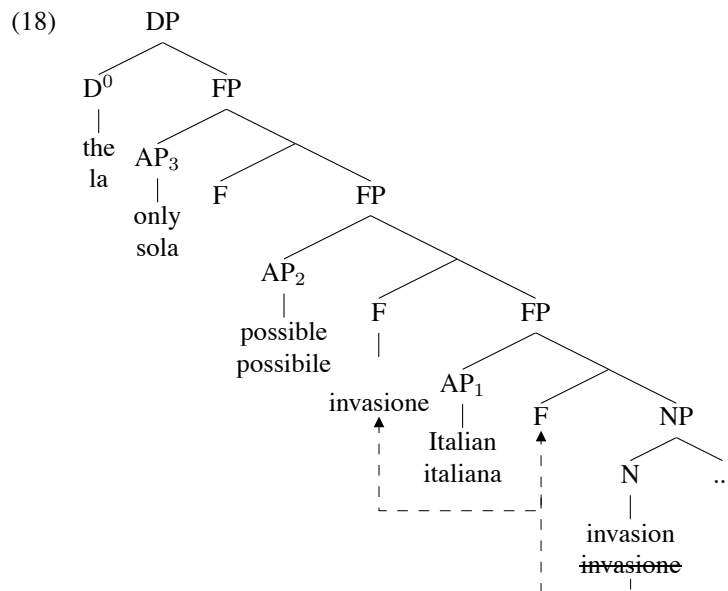

Thus besides hosting adjectives, these functional projections have the additional purpose of providing landing sites for the moved N. Also, not only does this kind of approach offer a basis for a uniform analysis of adnominal adjectives, it more specifically provides a straightforward method for analysing postnominal adjectives as a result of the noun moving past them. In other words, “postnominal” adjectives are actually stranded in postnominal position (rather than base-generated postnominally due to parametric variation).

Furthermore, rigid adjective orderings (cf. Sproat and Shih 1988, 1991) have been argued to result from a rigid, universally fixed hierarchical ordering of functional heads that carry specific semantic/conceptual information (i.e. a *functional sequence* / *fseq* in the terminology of Starke 2004); for instance:

- (19) a. Cinque (1994)
- i. Serialization of adjectives with event nominals:
 POSS >> CARDINAL >> ORDINAL >> SPEAKER-OR. >> SUBJ.-OR.
 >> MANNER >> THEMATIC
 - ii. Serialization of adjectives with object-denoting nominals:
 POSS >> CARDINAL >> ORDINAL >> QUALITY >> SIZE >> SHAPE
 >> COLOR >> NATIONALITY
- b. Scott (2002)
- DETERMINER >> ORDINAL NUMBER >> CARDINAL NUMBER >> SUBJECTIVE COMMENT >> ?EVIDENTIAL >> SIZE >> LENGTH >> HEIGHT >> SPEED >> ?DEPTH >> WIDTH >> WEIGHT >> TEMPERATURE >> ?WETNESS >> AGE >> SHAPE >> COLOR >> NATIONALITY/ORIGIN >> MATERIAL >> COMPOUND ELEMENT >> NP

(Laenzlinger 2005:59) suggests that several of Scott’s rather fine-grained adjectival classes can be grouped together in five semantic “meta-classes”:

- (20) [QUANTIF Ordinal > Cardinal] >
 [SPEAK-ORIENT Subjective Comment > Evidential] >
 [INTERNAL PHYSIC PROPERTY Size > Length > Height > Speed > Depth > Width] >
 [MEASURE Weight > Temperature > ?Wetness > Age] >
 [EXTERNAL PHYSIC PROPERTY Shape > Color > Nationality/Origin > Material]

Analyses that try to encode AORs directly in terms of a rigidly ordered fseq of semantic classes have been criticized on various accounts. (Svenonius 2008:35), for instance, notes:

For one thing, the categories are not well-motivated outside of the adjectival ordering phenomenon that they are introduced to describe. That is, they do not carry much explanatory force. Secondly, the actual observed orderings are not as rigid as such an approach would seem to predict

He proposes a less fine-grained, but independently motivated hierarchy that arises from a functional decomposition of the DP (see section 1.1.2). So he argues for a moderately fine-grained layered noun phrases structure (drawing on both Zamparelli 2000 and Borer 2005), where AORs essentially result from adjectives being merged in different domains:

- (21) a. ... [**KiP** AP₁ **Ki** [**SortP** AP₂ **Sort** [**nP** AP₃ **n** [**NP** AP₄ **N**
 b. AP₁: focused adjectives
 AP₂: gradable subjective adjectives
 AP₃: non-gradable intersective adjectives
 AP₄: idiomatic adjectives

Such an approach entails that the adjective classes themselves are also construed as less fine-grained, and that there is essentially a rather small number of relevant adjective classes; see also Truswell 2004, 2009; McKinney-Bock 2010. Cinque (2010) presents a revision of his 1994 analysis (see next section).

1.2 More on Adjectives

1.2.1 (NON-) Intersectivity, Predicativity, Restrictivity

Adjectives are often divided into semantic classes according to the entailments the license. The best known such classes are (non-) intersective and (non-) subjective adjectives (for instance Partee 2003, 2010):⁸

⁸NB: In terms of entailments, intersective adjectives are necessarily subjective, and non-subjective adjectives are necessarily non-intersective.

- (22) a. an adjective A is **intersective** iff for every noun N
 $[[AN]] = [[A]] \cap [[N]]$ $[AN](x) \rightarrow x \text{ is } A \ \& \ x \text{ is } N$
 John is a blond tennis player \rightarrow John is blond and John is a tennis player
- b. an adjective A is **subjective** iff for every noun N
 $[[AN]] \subseteq [[N]]$ $[AN](x) \rightarrow x \text{ is } N$
 John is a bad tennis player \rightarrow John is a tennis player
 Jumbo is a small elephant \rightarrow Jumbo is an elephant
- c. an adjective A is **non-subjective** iff for every noun N
 $[[AN]] \not\subseteq [[N]]$
- i. (no entailments either way)
 John is an alleged thief $\not\rightarrow$ John is (not) a thief
 - ii. $[AN](x) \rightarrow \neg x \text{ is } N$ (\sim privative adjectives)
 John is a former president (AT t^0) \rightarrow John is not a president (AT t^0)

Contrary to what this classification seems to suggest, however, (*non-*) *intersectivity* and (*non-*) *subjectivity* (as well as a number of other semantic aspects) are more properly understood as a property of (a given instance of) adjectival modification, rather than an inherent (or lexical) property of adjectives.

Adjectives have also been classified according to whether they are predicative or attributive; here some clarification of terminology is in order. Sometimes the terminology is used to make reference to the actual occurrence of a given adjective. In this sense, a predicative adjective is one that occurs in a predicative context such as in post-copular position (*the president is blond*), whereas an attributive adjective is one that occurs in adnominal position (*the blond president*). The same terminology is also used to make reference to the potential occurrence of a given adjective. In this sense, an adnominal adjective (*the blond president*) is considered predicative if it can, in principle, occur in post-copular position (*the president is blond*), whereas an attributive adjective is one that can only occur in adnominal position (*the former president*), but not in a predicative context (**the president is former*).

On the latter conception, it should be noted that adjectives that can occur in both adnominal and post-copular position do not always have the same interpretation (example adopted from Sadler and Arnold 1994:194):

- (23) the editors (who) are/were present
 \sim the editors present
 \neq the present editors

Thus for the sake of clarity, instead of simply talking about predicative adjectives, I will often use the label *adjectives with a predicative reading*, which refers to adnominal adjectives that have an interpretation that is also found in post-copular

- b. ‘Every word was deleted; they were unsuitable.’ (non-restrictive)
(Larson and Marušič 2004:275)

On the restrictive reading in (26a), the adjective expresses a restriction on the set of words that were deleted suggesting that suitable words were not deleted. On the non-restrictive reading in (26a), it does not express such a restriction meaning that all words were deleted.

There is, however, little consensus on how to formally approach that restriction (or the absence thereof),⁹ and explicit formalizations do not necessarily capture all the relevant data. In addition, there is no consensus on whether the absence of restrictivity should be conceived of as such (**not** restrictive), or rather as a specific property (**non**-restrictive).

On a set-theoretic formulation as suggested for instance by Piñón (2005); Alexiadou (2012), restrictive modification targets a proper subset in the noun’s extension. Adjectival modification where the denotation of the modified noun is co-extensive with the denotation of the noun alone, on the other hand, is usually considered to be the hallmark of non-restrictive modification:

- (27) a. an adjective A **restrictively** modifies N in c iff

$$\llbracket \mathbf{A\ N} \rrbracket^c \subset \llbracket \mathbf{N} \rrbracket^c \quad (\text{i.e. } \exists x: x \in \llbracket \mathbf{N} \rrbracket \ \& \ x \notin \llbracket \mathbf{A\ N} \rrbracket)$$
 b. an adjective A **nonrestrictively** modifies N in c iff

$$\llbracket \mathbf{A\ N} \rrbracket^c = \llbracket \mathbf{N} \rrbracket^c \quad (\text{i.e. } \forall x: x \in \llbracket \mathbf{N} \rrbracket \rightarrow x \in \llbracket \mathbf{A\ N} \rrbracket)$$

We also find reverse formulations where “restrictive adjectives” is the label for a rest category:

- (28) a. An adjective Adj modifying a noun N is **nonrestrictive** in c iff

$$\llbracket \mathbf{A\ N} \rrbracket^c = \llbracket \mathbf{N} \rrbracket^c$$
 b. Otherwise Adj is **restrictive**
 (adopted from Leffel 2012)

On a context-independent conception, the definition for non-restrictivity in (27b)/(28a) would only capture logical or pragmatic tautologies like *unmarried bachelor* or *round circle*, but examples like (26) suggest that the set denoted by the head noun be defined relative to a contextual parameter c “where c is your favorite list of semantic parameters” (Leffel 2012:2).

According to (27), in order to be even eligible for either restrictivity or non-restrictivity, the adjective must pass the test at least for subsectivity. Non-subsective adjectives like “alleged” are not defined as either restrictive or non-restrictive according to (27) because the modified noun denotation (e.g. *alleged thief*) is neither

⁹It can be and has been approached, for example, in terms of pragmatics, presuppositions, IS (topic/focus), discourse structure, referentiality (deixis/anaphora), and scope.

a subset of the noun denotation nor identical to it. They should reasonably be considered *not restrictive*. On Cinque's (2010) account, however, modifiers like "alleged" belong with direct modifiers (see below), and as such, they are considered *non-restrictive* (cf. table 1.2). And on the other hand, given a definition like (28), this kind of modifiers should be considered *restrictive* because they are not nonrestrictive in the sense of (28a).

In addition, there are other kinds of modifiers that are often contrasted with restrictive ones, viz. appositive and expressive modifiers. Appositives provide additional information about a referent, and license a 'by-the-way' (BTW) paraphrase. Expressives do not denote properties at all, but rather express the speaker's attitude towards the referent of the noun phrase. Appositive/expressive modification is sometimes conflated with non-restrictive modification, which is not unproblematic. (Non-/not) restrictive and appositive/expressive modification will be a recurrent theme in the following three chapters, and a number of issues will be addressed in more detail in the course of the discussion.

1.2.2 Predicativity and Adjectives as Reduced Relative Clauses

One central idea that has been well entrenched in the debate on adjectives, one way or another, is the assumption that there are two different kinds of adjectives or that adjectives have two distinct "sources". The distinction has been argued to exist on both (morpho-) syntactic and semantic grounds, and has been implemented in various ways (Bolinger 1967; Siegel 1976; Higginbotham 1985; Sproat and Shih 1988, 1991; Sadler and Arnold 1994; Alexiadou 2001; Alexiadou and Wilder 1998; Demonte 2008; Cinque 2010; Ramaglia 2011; and others). Bolinger (1967), for instance, distinguishes *reference modification* and *referent modification*. Reference modifiers make a substantial contribution to the NP denotation often denoting properties that are inherent or characteristic with respect to the NP denotation. Referent modifiers, on the other hand, predicate a property of a referent that may only hold on a certain occasion; referent modification is purely extensional. Siegel (1976) proposes that there are two classes of adjectives that differ with respect to a number of semantic properties as a consequence of their respective semantic type:

a predicative/RRC source (\rightarrow referent modifiers), whereas prenominal adjectives must have a non-predicative source (\rightarrow reference modifiers).

A different kind of evidence for the idea that at least some adnominal adjectives are RRCs is presented by Sproat and Shih (1988, 1991) who introduce the distinction *direct* vs. *indirect* modifiers/modification (DM vs. IM) on the basis of Chinese data. Direct modification, which involves a bare adjective, is syntactic word formation, and semantically, direct modifiers are functions from common nouns to common nouns. Indirect modifiers, on the other hand, are characterized by carrying the suffix -DE, and they “are [...] syntactically and semantically just like relative clauses” (Sproat and Shih 1988:476). What supports this latter idea in particular is the fact that the same suffix -DE is used to form relative clauses:

- (32) a. hei -de shu
black -DE book
'a/the black book'
- b. [wo xi-huan] -de shu
[I like] -DE book
'a/the book that I like'
- (Sproat and Shih 1988:476)

Recall that the main objection against the general RRC analysis was that not all adjectives can occur in predicative contexts, cf. (31). Interestingly, only adjectives that can occur in predicative contexts can carry the suffix -DE, whereas inherently non-predicative adjectives can only be used as direct modifiers, but not as indirect modifiers (i.e. they cannot carry the suffix -DE):

- (33) a. qian zongtong (DM)
former president
- b. *qian -de zongtong (IM)
former -DE president
- (Sproat and Shih 1988:476/7)

This evidence is very suggestive because it simultaneously establishes connection between indirect modifiers and relative clauses (via the suffix -DE), and a connection between indirect modifiers and a “predicative source”.

One influential analysis of RRCs is Kayne (1994) who proposes that all adnominal adjectives are literally generated as syntactic predicates inside a relative clause (i.e. a full CP) which is the complement of D, cf. (34a). Word order differences (A N vs. N A) are the result of either moving AP or NP to Spec-CP, cf. (34b) and (34c), respectively:

- (34) a. [_{DP} D [_{CP} [_{IP} NP AP]]]
- b. [_{DP} D [_{CP} AP_i [_{IP} NP t_i]]]
- c. [_{DP} D [_{CP} NP_i [_{IP} t_i AP]]]

This analysis has been modified to the effect that only indirect modifiers, i.e. adnominal adjectives that can occur in a predicative context, should be analysed as

underlying syntactic predicates (in particular Alexiadou and Wilder 1998; Alexiadou 2001; Cinque 2010).

1.2.3 Cinque (2010)

Partly in response to criticism of his (1994) proposal (see above), Cinque (2010) presents an analysis of adnominal adjectives that involves two substantial innovations. First of all, he proposes that N movement is not, in fact, head movement, but phrasal movement. On a head movement account, the relative (surface) ordering of adjectives remains unaltered, thus N⁰ movement past adjectives leaves unexplained the existence of mirror-image orderings, and the fact that postnominal adjectives (may) have scope over prenominal adjectives. In addition, Cinque notes that there are systematic interpretive differences between pre- and postnominal adjectives, and between Romance and Germanic (English) that a pure head movement account is incapable of providing a unified analysis for.

The second major innovation, which directly addresses those interpretive differences, is the claim that adnominal adjectives have two different sources, an *Indirect Modification* (IM) and a *Direct Modification* (DM) source. The terminology is adopted from Sproat and Shih (1988, 1991), see above; indirect modifiers are syntactic predicates in a RRC, whereas direct modifiers are APs merged in dedicated functional projections (so only the analysis of direct modifiers is an immediate continuation of Cinque 1994). The general underlying ordering he proposes is **Det** >> **IM** >> **DM** >> **N**; i.e. direct modifiers are structurally closer to the noun than indirect modifiers. Note that Cinque's notion *source* has two components. On the one hand, it makes reference to a structural location (closer to the noun vs. further away from the noun), on the other hand, it entails that the respective adjectives are different kinds of adjectives (direct modifiers vs. RRCs). According to Cinque, both sources are systematically associated with a respective set of semantic readings:

DET	INDIRECT MODIFICATION / RRC	DIRECT MODIFICATION	NP
	stage (or individual) level	individual level	
	restrictive	non-restrictive	
	implicit RC (“possible”)	modal (“possible”)	
	intersective	non-intersective	
	relative (to comparison class)	absolute	
	comparative (superlative)	absolute (superlative)	
	(non-) specificity inducing	specificity inducing	
	epistemic <i>unknown</i>	evaluative <i>unknown</i>	
	discourse anaphoric <i>different</i>	NP dependent <i>different</i>	
	deictic	generic	
	only literal interpretation	possibly idiomatic	
	further away from N	closer to N	
	not rigidly ordered	rigidly ordered	
	possible in predicate position	not possible in predicate position	

Table 1.2: *Properties of indirect and direct modification (Cinque 2010:33)*

Comparing mainly English and Italian, Cinque argues that the surface distribution of APs in these two languages can be described as follows:

- (35) a. IM >> DM >> N >> IM (English)
 b. DM >> N >> DM >> IM (Italian)

That means that, in English, adjectives may be ambiguous between two readings prenominal, but unambiguous postnominal, and vice versa in Italian. To give an example from English (originally noted by Bolinger 1967), while the prenominal adjective in (36a) is, in principle, ambiguous between an individual level (IL) and a stage level (SL) reading, the postnominal adjective in (36b) can only have an SL reading:

- (36) a. the visible stars
 a. visible in general (IL)
 b. currently visible (SL)
- b. the stars visible
 a. *visible in general (IL)
 b. currently visible (SL)

An argument in favor of the reality of two systematically different interpretations can be adduced from the observation that two adjectives with superficially opposing meanings can occur in one and the same noun phrase without expressing a contradiction, provided they occupy the “appropriate” slots, IM and DM, respectively (cf. Larson 1998:155/6; Cinque 2010:19):

NUMP) analogously to subject raising in the clausal domain. (Adger 2004:268-75), on the other hand, argues that only agentive possessors are merged in Spec-nP, whereas actual POSSESSORS ('Peter's/my car') are merged in Spec-POSSP.

Various alternative analyses of possessors have been proposed that do not primarily focus on their potential subject-like properties. Delsing (1993, 1998), for instance, argues that pronominal possessives are always merged as structural heads in POSS⁰, whereas non-pronominal possessors such as DP-genitives and possessive PPs are generated as complements (i.e. not as specifiers) of N. Other authors have argued, based on a fine-grained analysis paying close attention to aspects such as ellipsis, coordination, focus, definiteness, and certain morphological details, that at least some pronominal possessives are clitic or determiner elements that occupy the D⁰ position, or move there from POSS⁰, respectively (Cardinaletti 1998; Schoorlemmer 1998; Ihsane 2000, 2003). In addition, most analyses consider Spec-DP a potential surface position of possessors like Saxon Genitives in English (for instance Abney 1986, 1987); dative possessors in Hungarian (cf. Szabolcsi 1994); certain focalized possessors (cf. Julien 2005a).

In short, at least the following potential merge positions and landing sites have been proposed for the various kinds of possessive elements (indicated by bold-print):¹¹

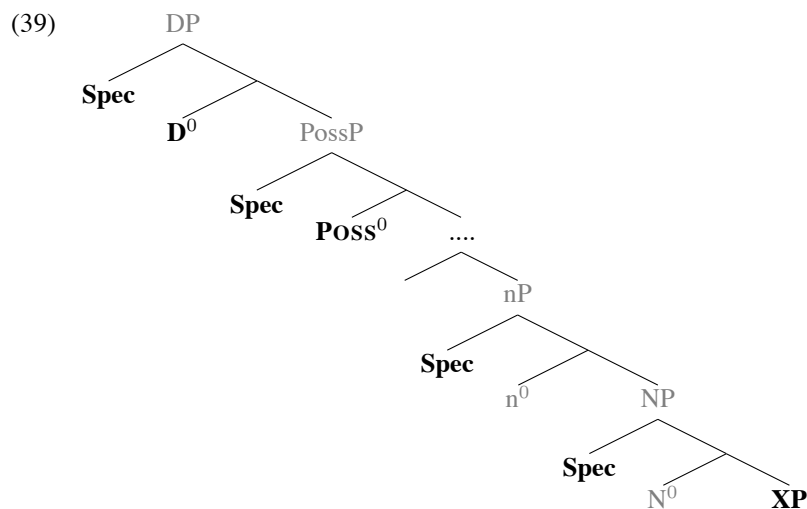

Positional considerations aside, there are certain semantic aspects of possession such as the nature of the relation between possessor and possessum. This will, by and large, be the topic of part II of this thesis.

¹¹This tree is an extended version of the one given in (Alexiadou et al. 2007:575).

1.4 The Data

The bulk of the data presented in the discussion has been collected in the course of the past eight years (more specifically since Pfaff 2007) from various sources (novels, comics, newspapers, gossip magazines, internet,¹² and interviews with native speakers).

In addition, I conducted an online survey in Iceland autumn 2012 the main purpose of which was to elicit judgments. The survey itself consisted of 11 questionnaires that were answered by 638 participants. The participants were given a number of options and had to assess their felicity (*fine*, *ok*, *questionable*, and *bad*), where each degree of felicity corresponds to a numerical value (3, 2, 1, and 0, respectively). Those are added up and divided by the number of respective participants in order to deliver an average score. I will treat average scores above (and including) 2.00 as *fine*, which is sometimes indicated in the examples by *ok*, but usually, it will not be marked at all. Average scores ranging from 1.50 to 1.99, I consider *slightly marginal*, which will be indicated by “?”, and average scores from 1.00 to 1.49 will be considered *very marginal*: “?”. Average scores below 1.00, I will consider *bad*, in fact, electrocutingly bad, as a reminder of which I will use the symbol “✂” in the examples.

In order to give a rough idea of the (error) margin, examples that are expected to be fine, consistently scored above 2.50, though they rarely achieved the high-score 3.00. On the other hand, examples that are expected to be bad, usually score below 1.00. However, for the majority of examples there were no previous expectations other than indications by informants from interviews prior to the survey. But all examples used in this thesis have been (extensively) discussed with several native speakers (both young and old, linguists and non-linguists). Examples for which I have no scores nor the opinion of at least five native speaker informants, will be commented on in a footnote. Judgments for such cases will appear as superscripts, for instance “?”. Other than that, I take it that the judgments reported here *are* representative even though some native speakers may disagree in individual cases.

1.5 Road Map

The majority of studies that address the Icelandic noun phrase are comparative in nature, that is, they examine Icelandic in the context of Scandinavian or Germanic languages (for instance Delsing 1993; Vangsnes 1999b, 2004; Julien 2002, 2005a;

¹²A substantial body of online data was compiled in the course of the seminar “Corpus Linguistics” taught autumn 2010 by Michal Starke. The annotated online corpus *Mörkuð íslensk málheild* (<http://mim.hi.is>) proved to be another valuable resource when browsing for specific patterns.

Roehrs 2006, 2009; Lohrmann 2008, 2010). This thesis focuses first and foremost on Icelandic, and its primary goal is to develop an analysis of the *Icelandic* data. No attempt is made to make any claims pertaining to Scandinavian languages at large. It is not intended, either, to address the issue of (dialectal) variation among Icelandic speakers – geographic or other (concerning age, education ...). In general, I will try to establish generalizations that apply to Icelandic at large, but in individual cases, where some innovation seems to be on its way, I will focus on the conservative variety. Only in chapter 7 will I pay more attention to a dialectal feature than to the standard variety. The strong focus on Icelandic *data* has another side effect: the discussion of certain theoretical aspects and review of the literature or alternative proposals will often be kept to a minimum in favour of a more detailed description of the data. In many cases, I will not spell out the technicalities or a full implementation of certain aspects of the analysis in detail.

Broadly speaking, this thesis is a descriptive study of definite noun phrases in Icelandic aiming at establishing a number of non-trivial empirical generalizations and providing novel data along the way. The overarching goal is to develop an analysis of specific aspects of the Icelandic noun phrase involving definiteness morphemes (i.e. articles), adjectival inflection, the syntax and semantics of adjectival modification, and genitival/possessive modification. In describing the data, I will draw on both (morpho-) syntactic and interpretive properties. I will be particularly interested in the syntax/semantics interface in the sense that I will focus on those kinds of semantic interpretation that are a consequence of the syntactic configuration rather than, say, lexical properties of the items involved. I will show that Icelandic provides strong evidence for a segmentation of the noun phrase into four distinct zones (layers), and that modification is simply a matter of the modifier being merged in a specific zone.

One methodological goal of this thesis is to keep the analysis as simple as possible. As already mentioned in the introduction, I assume that the suffixed article is derived by movement of a nominal constituent to a higher position. A concomitant claim is that, given an appropriately articulated noun phrase architecture, we can derive all the attested variety with one particular syntactic movement operation (or the lack thereof). By that, I mean that the movement only targets a specific nominal category that moves as a whole and in one fell swoop. This, in turn, entails that I dispense with pure word order movement (WOM) operations like evacuation and successive remnant movement.

Below, I give a brief summary of the individual content chapters:

PART I addresses adjectival (and numeral) modifiers and has the overarching goal of showing that the Icelandic data provide ample morpho-syntactic, syntactic and semantic evidence that the Icelandic noun phrase can be segmented into (at least) four distinct layers or zones.

- **Chapter 2:** Introduction of core data on adjectives (and numerals): we find four different (surface) patterns of adjectival modification involving article, adjective and noun. In addition to a short characterization of some rarely/never discussed patterns, I will establish two central ideas: (i) the “One-Article” analysis (OAA): suffixed and free article are two surface manifestations of one and the same underlying element; and (ii) the distribution of adjectival inflection with respect to definiteness: weakly inflected adjectives are in the scope of some definiteness morpheme, strongly inflected adjectives are not. That is, weak inflection is triggered, strong inflection is the default that occurs precisely when weak inflection is not triggered.
- **Chapter 3:** This chapter is dedicated to definite noun phrases modified by strongly inflected elements such as adjectival appositives, expressives, “little” partitives and positional predicates. Besides discussing the data as such, the purpose of this chapter is to show that all those various modifiers are merged outside the definite noun phrase (*articleP*) as it were, but still part of the same extended nominal projection (KP). Adjectival inflection thus provides one first essential diagnostic for dividing the noun phrase into two realms: *articleP*-external vs. *articleP*-internal.
- **Chapter 4:** Various syntactic and semantic aspects of the remaining three patterns, whose common denominator is that the adjective involved bears weak inflection, will be addressed in this chapter. I will provide more evidence for OAA, and develop a specific analysis of the article phrase: the suffixed article is the result of movement of a specific nominal constituent to *Spec-articleP*; modifiers merged inside that constituent move along, while modifiers merged outside get stranded in postnominal position. In the course of the discussion, I will show that weak *articleP*-internal adjectives are merged in three different zones.

PART II is dedicated to genitival and possessive modification. While the vast part of pronominal possessives can be easily integrated into the structure as developed in part I, DP-genitives call for a novel structural device in order to account for the syntactic and semantic relationship between head noun and genitive which I label \mathfrak{N} . The conception of \mathfrak{N} as a non-substantial category without a fixed position in the fseq, in turn, will allow us to analyse semantic differences apparently stem-

ming from the semantics of the head noun as a consequence of \mathfrak{N} being merged in different zones.

- **Chapter 5:** Introduction of core data on genitives/possessives: I will discuss the distribution of possessive modifiers relative to numeral and adjectival modifiers and the head noun, and show that we have to assume a high and a low position for possessive modifiers; full DP genitives, on the other hand, only occur in the low position.
- **Chapter 6:** In this chapter, various semantic aspects of possessive constructions are addressed in conjunction with definiteness marking (on the head noun or on adjectives) or the lack thereof. I argue that possessives/genitives in the low position do not formally contribute to the definiteness of the noun phrase, as opposed to possessives in the high position. I will furthermore address the issue of relationality. Finally, I will summarize the findings so far and provide an analysis for “high” possessives.
- **Chapter 7:** In this chapter, it will be shown that “low” pronominal possessives and DP-genitives cannot be accounted for by the analysis as it stands. In particular, the phenomenon of “genitive stranding” will turn out to pose a serious challenge. Drawing on Adger (2013), I will modify my architectural assumptions, and introduce \mathfrak{N} -structures which take the head noun constituent as a specifier and the genitive as a complement. This modification will allow to account for genitive stranding, and for the semantic relation between head noun and genitive in a way that makes redundant the distinction between *common* and *relational* nouns.
- **Chapter 8** summarizes the central aspects established in this thesis abstracting away from and going beyond the concrete data discussed in the thesis. The segmentation of the noun phrase structure into four distinct zones can be regarded as one of the most fundamental features of the analysis developed here. Zones are (sub-) constituents of the extended projection determined by the nominal fseq; zones “grow” incrementally, as it were, with each zone defining the denotation of a distinct entity (nP-zone: concepts; *ix*P-zone: kinds; *article*P-zone: individuals; KP-zone: referential expressions). This conception of zone will allow us to considerably simplify and unify the (syntax and) semantics of adjectival and genitival modification. Adjectives (and genitivals, for that matter) are not of different kinds; their properties depend on the entity they modify, which, in turn, is determined by the zone in which the modifier is merged.

Part I

Adjectives and the Icelandic Article System

Part I of this dissertation comprising chapters 2 through 4 will introduce, discuss and analyse a substantial body of data. The main purpose is to make visible some basic morpho-syntactic, structural and interpretational properties underlying the Icelandic noun phrase architecture and the Icelandic article system that have not been previously noticed or only insufficiently discussed – without striving for exhaustivity. The major part of the discussion will be devoted to the syntax and semantics of adjectives, and the relationship between adjectives and the definite article. The reason for this strong emphasis on adjectives lies in the diversity displayed by definite noun phrases involving adjectival modification; we find four different surface constellations of adjectival modification that will be introduced in chapter 2. Apart from linear ordering, particular attention will be paid to the role of adjectival inflection, the relationship between the two definite articles, and the relationship between the suffixed article and the head noun. The discussion on adjectives includes a number of other modifiers, notably numerals and cardinal quantifiers.

Chapter 2

Articles, Patterns and Adjectival Inflection

Icelandic has no indefinite article, but two definite articles, a freestanding prenominal one (ART) and a suffixed postnominal one (DEF). In definite noun phrases, we find four different (surface) patterns involving the elements {ARTICLE, ADJECTIVE, NOUN}.¹ In (40), the abstract template and an example of each pattern is given:

- (40) a. **A.WK N-DEF** (I)
gul.i bíll - inn
yellow.WK car - DEF
'the yellow car'
- b. **ART A.WK N** (II)
hinn fræg.i leikari
ART famous.WK actor
'the famous actor'
- c. **N-DEF A.WK** (III)
heimspekingur - inn mikl.i
philosopher - DEF great.WK
'the great philosopher'

¹Whereas in definite noun phrases without adjectives, and in indefinite noun phrases, we only find one surface pattern for each:

(1) bíll - **inn**
car - DEF
'the car'

(2) **gul.ur** bíll
yellow.STR car
'(a) yellow car'

d. **A.STR N-DEF** **(IV)**

blá.r himinn - inn
 blue.STR sky - DEF
 ‘the blue sky’

A formal characterization of their differences and similarities with respect to their surface manifestation can be given in terms of four binary parameters: (i) *suffixed* article (DEF) vs. *free* article (ART), (ii) *weak* (WK) vs. *strong* (STR) adjectival inflection, (iii) *prenominal* vs. *postnominal* adjective, and (iv) *pre-articular* vs. *post-articular* adjective.² In table 2.1, an overview of the four patterns with respect to those parameters is given (distinctive features marked in bold):

(I)	DEF	WK	prenominal	pre-articular
(II)	ART	WK	prenominal	post-articular
(III)	DEF	WK	postnominal	post-articular
(IV)	DEF	STR	prenominal	pre-articular

Table 2.1: *The four Patterns*

A careful examination of this diversity will allow us to scrutinize syntactic and semantic aspects of the Icelandic noun phrase that are not immediately accessible without an adjectival modifier. In the following discussion, I will refer to these patterns by the Roman numbers as given in (40). Note that the notion *pattern* is essentially a descriptive term referring to a surface constellation rather than a theoretical one that denotes a specific construction type. The discussion will show in particular that, in spite of displaying a range of pragmatic and semantic differences, patterns (I)-(III) have certain morpho-syntactic and ordering commonalities, and can all be derived from an underlying [ARTICLE - A - N] sequence. Pattern (IV), on the other hand, will turn out to be quite different in that respect. That very surface pattern can be instantiated by a range of semantically different elements. I will argue that it results from the adjective (and other strongly inflected elements) being merged at a different structural location.

²By “pre/post-articular”, I first and foremost mean a position linearly preceding/following the definite article glossing over the distinction DEF/ART. While the parameter *post-articular* will turn out to have some deeper significance insofar as it is the common denominator of patterns (II) and (III) at an abstract level, the parameter *pre-articular* will not reveal any intimate connection between patterns (I) and (IV).

2.1 The Definite Article(s)

In this section, I will provide some general information about the the two definite articles in Icelandic, and, summarizing Pfaff (2007, 2009), I will show that there is reason to believe that both articles are essentially two manifestations of one underlying core element. Notably the usually neglected pattern (III) will turn out to be a crucial factor in establishing this. Since the argumentation is based on a comparison of patterns (I)-(III), i.e. those involving a weakly inflected adjective, while strongly inflected adjectives will not be addressed here, weak inflection will not be marked in the glosses in this section.

2.1.1 ART and DEF

As already mentioned, Icelandic has, at least descriptively speaking, two definite articles: a freestanding, prenominal one (ART), and a suffixed, postnominal one (DEF). The attribute *prenominal* has to be qualified: ART cannot stand before a bare noun, or a noun that is only modified postnominally, cf. (41), but requires the presence of a pre-nominal modifier, typically, but not exclusively, an adjective, cf. (42):³

- (41) a. *hinir guðir
ART gods
- b. *hinn hestur sem vann hlaupið (Thráinsson 2007:112)
ART horse that won race.the
- c. *hinir fossar á Íslandi
ART waterfalls on Iceland
- d. *hinn bíll forsetans
ART car president.the.GEN
- (42) a. hinir fornu guðir *adjective*
ART ancient gods
'the ancient gods'
- b. hinar sjö höfuðsýndir *numeral*
ART seven cardinal-sins
'the seven cardinal sins'
- c. hinir mörgu fossar (á Íslandi) *cardinal quantifier*
ART many waterfalls on Iceland
'the many waterfalls (in Iceland)'
- d. hin tveggja barna móðir *measure genitive*
ART [two children]-GEN.PL mother
'the mother of two children'

³Therefore, ART is often referred to as *preadjectival* article, in particular, in traditional grammars.

The only (morpho-syntactic) restriction on DEF, on the other hand, is that it be suffixed to nouns only,⁴ independently of the absence or presence of a modifier. Note, however, that DEF does not normally attach to proper names. If a proper name is modified, ART is required:⁵

- (43) a. guli penni - nn
yellow pen - DEF
b. *guli - nn penni
yellow - DEF pen
c. * <vinsæla> Björk - in
popular Björk - DEF
d. hin vinsæla Björk
ART popular Björk

Since DEF cannot attach to adjectives, but only to nouns, ART or the demonstrative *sá* is used if the DP contains an adjective but no (overt) noun:

- (44) a. hið fagra
ART beautiful
'(the Platonic form of) beauty'
b. hinn látni / hin látna
ART deceased (m) / ART deceased (f)
'the deceased (male / female person)'
c. (guli bíllinn er fallegur) en sá svarti er ljótur
(yellow car.the is beautiful) but *sá* black is ugly
'... the black one ...'

This first glimpse thus reveals that there are systematic differences in the syntactic conditions on the proper use of DEF and ART.

At the same time, we do find systematic interdependencies between the two articles. Let us have a look at their inflectional paradigms in table 2.2:

⁴In this respect, the Icelandic (and, more generally, the Scandinavian) suffixed article is different from e.g. the suffixed article in the Balkan languages, which also attaches to adjectives.

⁵But if the adjective denotes a specific salient property, or is an established epithet, it follows the name, and no article is required:

- (1) a. Jón gamli
Jón old
'old Jón'
b. Lára klára
Lára clever
'clever Lára'
c. Eiríkur rauði
Eiríkur red
'Eric the Red'
d. Alexander mikli
Alexander great
'Alexander the Great'

	ART.MASC	DEF.MASC	ART.FEM	DEF.FEM	ART.NEUT	DEF.NEUT
NOM.SG	<i>h-in.n</i>	-(i)n.n	<i>h-in</i>	-(i)n	<i>h-ið</i>	-(i)ð
ACC.SG	<i>h-in.n</i>	-(i)n.n	<i>h-in.a</i>	-(i)n.a	<i>h-ið</i>	-(i)ð
DAT.SG	<i>h-in.um</i>	-(i)n.um	<i>h-in.ni</i>	-(i)n.ni	<i>h-in.u</i>	-(i)n.u
GEN.SG	<i>h-in.s</i>	-(i)n.s	<i>h-in.nar</i>	-(i)n.nar	<i>h-in.s</i>	-(i)n.s
NOM.PL	<i>h-in.ir</i>	-n.ir	<i>h-in.ar</i>	-n.ar	<i>h-in</i>	-(i)n
ACC.PL	<i>h-in.a</i>	-n.a	<i>h-in.ar</i>	-n.ar	<i>h-in</i>	-(i)n
DAT.PL	<i>h-in.um</i>	-n.um	<i>h-in.um</i>	-n.um	<i>h-in.um</i>	-n.um
GEN.PL	<i>h-in.na</i>	-n.na	<i>h-in.na</i>	-n.na	<i>h-in.na</i>	-n.na

Table 2.2: *Inflectional paradigms of ART and DEF*

When isolating the stems of DEF and ART, we notice that the former (*-in-*)⁶ is properly contained in the latter (*hin-*). We also observe that their inflectional endings are identical.⁷ This identity in particular covers cases such as the idiosyncratic NEUT.NOM./ACC.SG.

Furthermore, DEF and ART appear to be in “complementary distribution” insofar as they cannot co-occur:

- (45) a. *fræga verk - ið*
famous work - DEF
b. *hið fræga verk*
ART famous work
c. **hið fræga verk - ið*
ART famous work - DEF

Sigurðsson (1993)

These three observations – (i) proper containment of stem, (ii) identity of inflection, (iii) complementary distribution – together suggest that both articles actually are underlyingly the same element. Indeed, this is the view that has been advocated by traditional (and didactic) grammars (for instance Ólafsson 1915; Guðmundsson 1922; Jónsson 1927; Guðfinnsson 1943; Skúlason 1944; Einarsson 1945; Árnason 1980, 1983), and is typically expressed along the following lines (taken from Einarsson 1945:48; emphasis mine):

⁶The [I] of DEF is elided in certain morpho-phonological environments, cf.: *hestur-inn* ‘horse-DEF’ vs. *penni-nn* ‘pen-DEF’.

⁷With reference to (Spencer 1992:324), (Roehrs 2006:158)/(Roehrs 2009:115/6) states that DEF and ART “are not inflectionally identical in the feminine plural nominative: *-nir* vs. *hinar*.” This is blatantly wrong, as a look at table 2.2 reveals: *-nir* is, in fact, masculine plural, whereas feminine plural is *-nar* which is inflectionally identical to the feminine plural of ART: *hinar*.

Icelandic has **only one article**, the definite article *hinn* m., *hin* f., *hið* n. It may be placed before its noun, as in English, but only if an adjective intervenes [...] But it may also be suffixed to its noun [...] and if there is no adjective it must be suffixed [...] When suffixed, the article always lacks the *h* [...]

In other words, on the traditional view, ART is the full form of *the* definite article, whereas DEF is a phonologically reduced form with [h(I)] being lost in the process of suffixation.

Within the general framework of *Generative Grammar*, the traditional view has been re-interpreted as movement with subsequent cliticization (for instance Magnússon 1984; Sigurðsson 1993, 2006; Pfaff 2007, 2009, 2014). Call this view *One-Article-Analysis* (OAA). Put simply, OAA assumes [ARTICLE [(A) N]] to represent the “deep structure”, i.e. the first-Merge configuration, cf. (46a). If an adjective is present, either no movement takes place resulting in pattern (II) (ARTICLE is realized as ART), cf. (46b), or the [A N] constituent moves before the article which cliticises to the noun resulting in pattern (I) (ARTICLE is realized as DEF), cf. (46c). If no adjective is present, this movement is obligatory, cf. (46d):⁸

- (46) a. ARTICLE [(A) N]
 b. ART [A N]
 c. [A N]-DEF t
 d. N-DEF t

(46) gives a rather abstract, framework-independent scheme; this is for the reason that OAA can be implemented in various ways. Sigurðsson (1993), for instance, assumes that adjective and noun are head-adjoined and move to head-adjoin to the article yielding a complex A-N-DEF head. Pfaff (2007, 2009, 2014), on the other hand, assumes that adjective and noun form a phrasal unit and move to a specifier position. What both have in common is that they assume a high Merge position for the article element, i.e. above (numeral and) adjectival modifiers.

In this thesis, I will make the case for a modified version of OAA; in particular, I will argue for phrasal movement. Nonetheless, I will use the labels ART and DEF in the glosses and in the discussion. Before resuming the discussion of OAA in section 2.1.4, I will give a general characterization of patterns (II) and (III).

⁸Magnússon (1984) assumes that the article is moved behind the noun, but Sigurðsson (1993) points out that this would involve lowering. Such an operation is, however, illicit given standard assumptions such as the Proper Binding Condition and the Minimalist Extension condition. Instead, he proposes that it is the (adjective +) noun constituent that is moved (up) before the article. In this respect, I will follow Sigurðsson.

2.1.2 Literary Icelandic? – Pattern (II)

What I call pattern (I), which employs the suffixed article DEF, is by far the most common pattern of adjectival modification in definite noun phrases (in modern Icelandic). Pattern (II), on the other hand, more specifically “the preposed free article”, i.e. ART, “is almost nonexistent in common everyday language” (Sigurðsson 2006:196) – or so it seems. It is a well-known fact that ART “has a somewhat literary flavour” (Sigurðsson 1993:180), “normally yielding a formal/archaic flavor” (Vangsnes 1999b:130, fn. 24), and is thus largely confined to written language. This aspect has been pointed out for some 90 years (Guðmundsson 1922:81; Einarsson 1945:48; Kress 1982:82, 167-74; Árnason 1983:92; Magnússon 1984:94; Indriðason 1986:73; Sigurðsson 1993:180, Sigurðsson 2006:195/6; Delsing 1993:120; Thráinsson 1995:92, Thráinsson 2007:109; Vangsnes 1999b:130). This insight has given rise to the idea that a distinction be made between two linguistic systems, “Common/Colloquial Icelandic” and “Literary Icelandic” (cf. Julien 2002, 2005a; Roehrs 2006, 2009), and some researchers “assume that literary and common Modern Icelandic are two different **dialects**” (Roehrs 2006:96), or that “they [i.e. ART and DEF] could be taken to belong to different **grammars**” (Julien 2002:286), emphasis mine, A.P. Such a view entails that, a pattern (II) noun phrase is the “literary” version of the corresponding pattern (I) noun phrase; this is illustrated in the following example:

- | | | |
|------|--|----------------------|
| (47) | a. guli bíll - inn
yellow car - DEF | (common Icelandic) |
| | b. hinn guli bíll
ART yellow car | (literary Icelandic) |
- (Roehrs 2006:155)

Regarding stylistic peculiarities, this is, by and large, a valid assessment (with a *prima facie* plausible conclusion); ART/pattern (II) is indeed often a (stylistically) marked option. But that is not the whole story. Note that the distinction usually made in the literature is between the two article elements DEF and ART – not patterns, and what is compared is patterns (I) vs. (II). I will go into the specifics of the various patterns in the next two chapters; in this subsection, I will briefly comment on the status of ART / pattern (II) concerning its “literary flavour”.

First of all, it should be pointed out ART itself has never received a detailed discussion beyond being labeled literary, poetic, bookish, “non-existent” etc.; although, occasionally, some semantic properties have been pointed out *en passant*, see below. The truth is that pattern (II) is a rather complex creature with many (linguistically) interesting properties that are not always easily described, but most certainly go beyond its literariness. Indeed, at first glance, its actual occurrence

may not appear to be too frequent, but, basically, examples can also be found in all kinds of relatively informal texts (comics, gossip magazines, blogs, even spoken language). What is more, in many cases, the corresponding, otherwise default pattern (I) is ungrammatical/infelicitous – irrespective of stylistic considerations:⁹

- (48) ⇒ pattern (II)
- a. hinn meinti þjófur
ART alleged thief
 - b. hin svokallaða afstæðiskenning
ART so-called theory-of-relativity
 - c. hinn fullkomni glæpur
ART perfect crime
 - d. hinar ýmsu tegundir (af lýsingarorðum)
ART various kinds of adjectives
 - e. hinir mörgu fossar (á Íslandi)
ART many waterfalls on Iceland
- (49) ⇒ pattern (I)
- a. ??meinti þjófur - inn
alleged thief - DEF
 - b. ✘ svokallaða afstæðiskenning - in
so-called theory-of-relativity - DEF
 - c. ✘ fullkomni glæpur - inn
perfect crime - DEF
 - d. ✘ ýmsu tegundir - nar ...
various kinds - DEF
 - e. ✘ mörgu fossar - nir ...
many waterfalls - DEF

ART is the natural choice with a number of non-predicative adjectives, cf. (48a/b), and if the noun phrase as a whole expresses certain abstract notions (“pla-

⁹The average scores for the respective pattern (I) and (II) versions of the examples in (48a-d) and (49a-d) as retrieved in the survey are as follows:

(1) a. <i>the alleged thief</i>	(II): 2.66 = <i>ok</i>	(I): 1.20 = ??
b. <i>the so-called theory of relativity</i>	(II): 2.68 = <i>ok</i>	(I): 0.47 = ✘
c. <i>the perfect crime</i>	(II): 3.00 = <i>ok</i>	(I): 0.88 = ✘
d. <i>the various kinds</i>	(II): 3.00 = <i>ok</i>	(I): 0.46 = ✘

Recall that I consider examples that score 2.00 and above *fine* (*ok*), 1.50-1.99 *slightly marginal* (?), 1.00-1.49 *very marginal* (??), and below 1.00 *bad* (✘).

tonic ideas”, if you will; see also (44a)), cf. (48c). Moreover, it is categorically the only choice with cardinal quantifiers (in prenominal¹⁰ position), cf. (48d/e).

Also recall from (43c/d) that, in order to modify proper names, DEF cannot be used and ART must be used instead.

In addition, adnominal participial phrases occurring in definite noun phrases, especially when adverbially modified, naturally occur in with ART, but are strongly deviant with DEF (examples (50) are taken from Sigurðsson 2013):

- | | |
|--|--|
| (50) ⇒ pattern (II) | (51) ⇒ pattern (I) |
| a. hinn vandlega opnaði pakki
ART carefully opened packet | a. ??vandlega opnaði pakki - nn
carefully opened packet - DEF |
| b. hinar nýlega opnuðu dyr
ART recently opened door | b. ??nýlega opnuðu dyr - nar
recently opened door - DEF |

Whatever the deeper significance may be, these few examples should suffice to illustrate that a clear borderline between “Literary” and “Common/Colloquial” Icelandic cannot be drawn; ART does not simply produce the poetic version of a “common” pattern because, in many cases, the alleged colloquial counterpart involving DEF is bad. Thus for all grammatically relevant purposes, I will conclude that both ART and DEF belong to the same (grammar or dialect of) Icelandic, and disregard stylistic side-effects.

Furthermore, to the extent that the “literary flavour” is even real, the question is whether it is brought about by ART per se or rather by the configuration, i.e. what I refer to as pattern (II). Consider the following example:

- | | |
|---|--|
| (52) a. þín hetjulega baráttu
your heroic battle | b. þín langþráða hvíld
your long-awaited rest |
|---|--|

Possessives will be discussed in chapter 5, but I would like to point out the following: (i) like ART, prenominal possessives are a marked option (their default position being postnominal), (ii) examples like (52) also have a “literary flavour” (they typically occur in obituaries and poetic language), and (iii) in a structural sense, examples like (52) instantiate pattern (II). We thus find a rather striking parallel. Now, since prenominal possessives are formally identical to those that occur in (the default) postnominal position, presumably no-one would propose that it is the possessive in (52) that belongs to something like “literary Icelandic”, perhaps this could be said about the configuration. I will conclude analogously that it is not ART as such that has any particular poetic properties, rather the “literary flavour” is a side-effect of a pattern (II) configuration. And since I do not know whether it

¹⁰See also (42b). Note, however, that numerals do occur with DEF, but in postnominal position (which is the default case), see next subsection.

is even possible to isolate and identify specific stylistic properties, like Sigurðsson (1993:180), I will follow Magnússon (1984:94) and “ignore the stylistic differences.”

Finally, it should be mentioned that certain semantic aspects have been noted in the literature. Most saliently, it has been argued that an adjective in a pattern (II) configuration can only have a non-restrictive reading (whereas in pattern (I), it typically has a restrictive reading; for instance Árnason 1983:92; Vangsnes 1999b:130, fn. 24; Thráinsson 2005:98, Thráinsson 2007:4/89; Roehrs 2006, 2009; Pfaff 2007, 2009, 2014); see also section 2.1.4 below. In addition, it has been claimed that “the form with the prenominal article [i.e. ART] is not possible when the noun phrase has deictic reference” (Delsing 1993:121), that a pattern (II) noun phrase “is not necessarily referential” (Julien 2005a:57), and that the “preposed free article is mostly confined to abstract nouns” (Sigurðsson 2006:3).¹¹

In chapter 4, I will discuss a number of semantic properties of pattern (II) more thoroughly and show that both claims, although capturing important intuitions, are not unproblematic.¹²

2.1.3 Ignored, but Alive and Kicking – Pattern (III)

While patterns (I) and (II) (and pattern (IV), for that matter) have been discussed in the literature, pattern (III) – the pattern involving a postnominal adjective – has

¹¹Similar observations have already been made in the context of Old Norse: “The preposed article is used first of all if reference is made to the object as known, in which case the adjective denotes a *known* property of the *known* referent” (Nygaard 1905:48; translation mine).

¹²But I somewhat speculatively assume that these properties (“non-restrictiveness” and “non-referentiality”, or whatever they), and the stylistic side-effects mentioned above are just different manifestations of a more essential property of pattern (II).

not been noticed for Modern Icelandic,¹³ except for Pfaff (2007, 2009, 2014),¹⁴ and more recently Harðarson (2014b). More generally, postnominal adjectives in Modern Icelandic have been ignored, marginalized or denied to exist altogether. Vangsnes (1999:145), for instance, makes reference to “the fact that attributive adjectives **always** appear to the left of nouns in Icelandic, irrespective of whether the noun has raised or not” (emphasis mine), and Roehrs (2006:95) states that “the noun in the Modern Scandinavian languages **always** follows the adjective” (emphasis mine). Thráinsson (2007:88) writes: “Although adjectives typically precede the nouns they modify [...] the reverse order is sometimes found in relatively formal or bookish written Icelandic”, and gives the following example:

- (53) Gunnar átti hest grá.an
 Gunnar had horse grey.STR
 ‘Gunnar had a grey horse’

Note that (53) is not, as a matter of fact, an instance of pattern (III).¹⁵ (Norris 2011:9), on the other hand, explicitly rules out pattern (III) configurations.¹⁶

¹³It has been discussed in the context of Old Norse where pattern (III) noun phrases (and postnominal adjectives in general) were more frequent. In particular, it has been used to illustrate the historical development of the suffixed article:

- (1) a. ormr inn langi
 serpent the long
 b. ormrinn langi
 c. ormrinn (due to Smári 1920:41)
- ⇒ ormur - inn
 serpent - DEF

Roughly, it is assumed that the originally free pre-adjectival article has gone through the stages grammatical word >> clitic >> (inflectional) affix (for discussion, see for instance Faarlund 2004, 2009; Börjars and Harries 2008; van Gelderen and Lohndal 2008; Skrzypek 2009; also Roehrs 2006, 2009).

¹⁴That is, in the non-Icelandic literature. Occasionally, single examples of pattern (III) are mentioned en passant in Icelandic accounts, for instance (Smári 1920:264) or (Magnússon 1984:104).

¹⁵Thráinsson’s example involves a strongly inflected adjective in an indefinite noun phrase, while pattern (III) involves a weakly inflected adjective in a definite noun phrase. As opposed to pattern (III), the former type is indeed very archaic (frequently used in Old Icelandic Sagas) and hardly used in Modern Icelandic. Obviously, the two cases need to be kept apart, and, in the present context, the rather broad notion ‘postnominal adjective’ should be understood as relativized to ‘weak adjective following a (noun with a) suffixed article’ (see chapter 5, though).

¹⁶He gives an example of pattern (III) and starts it: “we predict [...] something like *bók-in rauða” ‘book-DEF red.WK.

Indeed, pattern (III) may be less frequently used than pattern (I), but, crucially, it is productively used in both spoken and written language, and examples may be found in all kinds of formal and informal texts (like comics and gossip magazines). In principle most adjectives can occur in this constellation, although certain adjectives are more typically used this way than others. For instance, adjectives that may be classified as evaluative are very frequently used in pattern (III):¹⁷

- | | |
|--|---|
| (54) a. rappari - nn umdeildi
rapper - DEF controversial | e. stúlka - n fagra
girl - DEF beautiful |
| b. leikkona - n fræga
actress - DEF famous | f. prins - inn hugrakki
prince - DEF brave |
| c. þáttur - inn vinsæli
(TV-)show - DEF popular | g. heimspekingur - inn mikli
philosopher - DEF great |
| d. lögreglustjóri - nn alræmdi
chief-of-police - DEF infamous | h. spurning - in sígilda
question - DEF classic |

In many cases, pattern (III) is the unmarked or more natural option, at least in comparison to pattern (I):¹⁸

- (55) ⇒ pattern (III)
- heimspekingur - inn mikli
philosopher - DEF great
 - afstæðiskenning - in svokallaða
theory-of-relativity - DEF so-called
- (56) ⇒ pattern (I)
- ✎ mikli heimspekingur - inn
great philosopher - DEF
 - ✎ svokallaða afstæðiskenning - in
so-called theory-of-relativity - DEF

¹⁷Also note that a small number of pattern (III) noun phrases are used as (quasi) names, epithets or name-like designations:

- | | |
|--|---|
| (1) a. ormur - inn langi
serpent - DEF long
(name of a famous viking vessel) | c. eyja - n græna
island - DEF green
(~ Ireland) |
| b. borg - in eilffa
city - DEF eternal
(~ Rome) | d. kreppa - n mikla
crisis - DEF great
'The Great Depression' |

¹⁸The average scores for (55b) and (56b) are as follows:

- (1) *the so-called theory of relativity* (III): 2.59 = ^{ok} (I): 0.47 = ✎ cf. fn. 9.

More examples will be given, and more contrasts shown below and in chapter 4. For the moment, the above examples should suffice to show that adjectives do occur postnominally in modern Icelandic, at least in definite noun phrases. In other words, pattern (III) does exist. Also the fact that it is often preferred over the “colloquial” standard pattern (I) shows that it is worthwhile examining it in its own right. I will, moreover, show that provides unique insight into the architecture of the (Icelandic) noun phrase, and that it is a crucial missing link in justifying OAA.

Note that numerals normally occur postnominally in definite noun phrases:

- (57) a. hestar - nir þrír
horses - DEF three
- b. höfuðsýndir - nar sjö
cardinal-sins - DEF seven

I will use the label “pattern” broadly so as to not only involve adjectival modifiers, but also numerals.¹⁹ Hence I will also refer to examples like (57) as pattern (III) constellations.

Numerals and adjectives may co-occur in postnominal position in the order numeral >> adjective:

- (58) a. drekar - nir fjórir svokölluðu
dragons - DEF four so-called
(= South Korea, Taiwan, Singapore and Hong Kong)
- b. myndir - nar tvær frægu
pictures - DEF two famous

Usually, we find only one adjective postnominally, but conceivably, more than one adjective may occur in that position:²⁰

- (59) a. hringur - inn eini sanni
ring - DEF one true

¹⁹See also (42b). Pattern (I), on the other hand, is categorically not an option for numerals:

- (1) *sjö höfuðsýndir - nar
seven cardinal-sins - DEF

See also section 3.3.2.

²⁰As for (59a), it is not immediately clear whether *ein.i* ‘one.WK’ counts as numeral or as adjective. An indication for the latter option is the fact that *einn* ‘one’ occurs both strongly and weakly inflected while the other inflecting numerals (*tveir*, *þrír*, *fjórir* ‘two, three, four’) do not even have a weak inflection. Also, when weakly inflected, ‘one’ can be conjoined with adjectives as can adjective and adjective, not least postnominally:

- (1) a. sannleikur - inn eini og hreini
truth - DEF one and pure
- b. nuddari - nn klári og yndislegi
masseur - DEF clever and charming

- b. hest - sins (← -s-in-s)
 horse - MASC.GEN.SG.DEFINITE

ART, on the hand, is typically seen as a genuine “prenominal determiner” (Julien 2005a:55) that is merged in D^0 (Delsing 1993). Moreover, ART has been argued to be a demonstrative by (Rögnvaldsson 1990:66). In this vein, Vangsnes (1999) argues that ART is a demonstrative generated in a specifier position. In particular, following Brugé (1996), he assumes that demonstratives (including ART) are merged below adjectives.

In addition, we have already seen that, based on stylistic criteria, some authors distinguish between two dialects or grammars called “Colloquial” and “Literary” Icelandic, where DEF belongs to the former, and ART to the latter (Julien 2002, 2005a; Roehrs 2006, 2009). Yet other authors do not address the difference between ART and DEF in any detail but nonetheless “[treat] the prenominal article as a different syntactic element from the suffixed article” (Norris et al. 2013:15, fn. 14; also Katzir 2011).

One way or another, these proposals can be subsumed under the heading *Two-Article Analyses* (TAAs). In the following, I will briefly comment on some aspects. For one thing, construing DEF as a part of a complex inflectional ending is for the most part terminological window dressing and obfuscates the fact that DEF itself can be parsed into stem and inflectional endings, such that the “definite inflectional ending” is doubly marked for case and ϕ -features:

- (61) a. hest - s - in - s cf. (60b)
 horse - MASC.GEN.SG - DEF - MASC.GEN.SG
 (*hestsins* - ‘the horse’s’)
- b. borg - ar - in - nar
 city - FEM.GEN.SG - DEF - FEM.GEN.SG
 (*borgarinnar* - ‘the city’s’)

At least for Icelandic, the idea that DEF merely spells out a (definiteness) feature on N is problematic. While it most certainly encodes definiteness, it cannot be simply treated as a piece of morphology (lexical affix/inflectional ending), especially not as a mere sub-component of N^0 because it displays a number of syntactic interactions with various modifiers, see chapter 4. Notably, we will see that there is reason to assume that adjective(s) and noun form a constituent to the exclusion of DEF. This observation is incompatible with all analyses that postulate a low position of DEF, i.e. below adjectives. All analyses mentioned above that construe DEF as inflectional ending, lexical affix or the spell-out of a feature on N belong to this category; the same goes for analyses that assume that DEF is merged in an X^0 position above NP, but below adjectives (Vangsnes 2004; Julien 2002, 2005a;

Roehrs 2006, 2009). Moreover, most of these “low-DEF” analyses have difficulties in handling certain interpretational issues some of which will be addressed below.

Similarly, the claim that ART is some kind of demonstrative is confronted with the simple fact that the canonical demonstratives *þessi* and *sá* may potentially co-occur with ART, but not with each other:²¹

- | | | |
|------|---|-------------------------------------|
| (62) | a. þessi hinn mikli maður
this ART great man | c. *þessi sá maður
this that man |
| | b. sá hinn góði maður
that ART good man | d. *sá þessi maður
that this man |

Thus (62a/b) show that canonical demonstratives and ART cannot occupy the same position, whereas (62c/d) show that actual demonstratives cannot be iterated. Hence, simply labeling ART as demonstrative misses an important generalization, makes the wrong predictions, and still begs the question of a criterion that justifies classifying ART with demonstratives rather than with DEF – given that ART and DEF are, in fact, in complementary distribution.

More aspects will be pointed out as the discussion proceeds, but for the moment, I conclude that DEF is not a mere inflectional ending nor is ART some kind of demonstrative. More generally, I take it that attempts to show the distinctness of ART and DEF in categorial terms are not convincing and leave a range of questions unanswered, whereas the facts illustrated above (p. 33) suggesting the sameness of the two remain unchallenged.

The idea that there may be two different grammars or dialects, “Literary” and “Common/Colloquial” Icelandic, was already refuted in section 2.1.2 where I showed that pattern (II) does not merely produce a “poetic” version of pattern (I), and that pattern (I) is not even felicitous in certain cases, seemingly for semantic reasons. But this last observation could actually be turned into an argument against OAA; consider the following example repeated from (48b)/(49b):

- | | | |
|------|--|------|
| (63) | a. hin svokallaða afstæðiskenning
ART so-called theory-of-relativity | (II) |
| | b. ↯ svokallaða afstæðiskenning - in
so-called theory-of-relativity - DEF | (I) |

Note that (63b) cannot, strictly speaking, be considered *ungrammatical*, because pattern (I) as such exists. Rather it is semantically strongly deviant. In section 2.1.2, I briefly alluded to the observation occasionally made in the literature

²¹Examples like (62a) are stylistically somewhat marked in Modern Icelandic, but note that the opposite order is completely ungrammatical (**hinn þessi mikli maður*). Example (62b) is taken from (Rögvaldsson 1990:66).

that a noun phrase involving ART can only have a non-restrictive reading. Leaving the specifics of (non-) restrictivity aside for the moment (see section 1.2), an adjective like ‘so-called’ most certainly cannot have a restrictive reading. Thus the contrast in (63) can be taken to mean that the a-example is fine because no restrictive reading (which ‘so-called’ does not have) is required, whereas the b-example is bad precisely because it suggests a restrictive reading of ‘so-called’, which is not available. Furthermore, merely focusing on the article elements, this could be taken to indicate a semantic difference between ART and DEF roughly along the following lines: DEF imposes a restrictive reading upon the adjective, ART a non-restrictive one. In other words, *prima facie*, we have a semantic argument in favour of a TAA.

Roehrs (2006, 2009), one of two analyses that examine the issue of (non-) restrictiveness in more detail, argues for a configurational approach. The title of his (2006) dissertation is program: Determiners move into DP. On his account, articles are merged in a low position art^0 (i.e. below adjectival projections) whence they move to D^0 . He considers (non-) restrictivity as a matter of scope: restrictive modifiers are in the scope of the definite determiner, non-restrictive ones are not. So in order to structurally capture the two readings of modifiers, he proposes “that different copies of the moved determiner are interpreted: the restrictive reading is derived by interpreting the determiner in its derived position, the non-restrictive one by interpreting the determiner in its base-position” (Roehrs 2006:118):

(64) a. *restrictive interpretation*

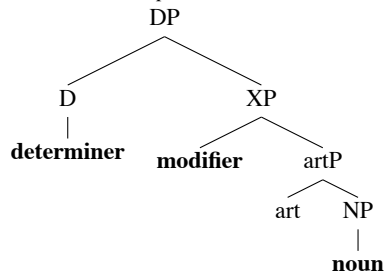

b. *non-restrictive interpretation*

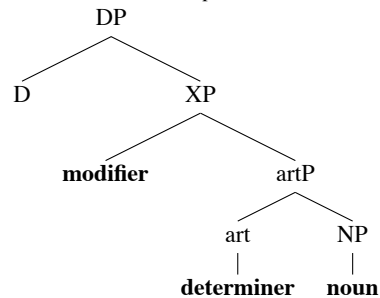

This is a rather intriguing approach to the challenge posed by examples like (63), but some comments are in order. First of all, it seems as though the article is interpreted exactly where it is not spelled out. (64b) represents the (semantically relevant) structure of a pattern (II) noun phrase with the article element (i.e. ART) having raised to D^0 where it is spelled out (op.cit.:60) – but the lower copy in art^0 is interpreted. Conversely, (64a) represents the semantic structure of pattern (I) noun phrase. The syntactic (and semantic) derivation of this constellation is a bit more complex (see op.cit.:107/8; 121-6), so I will simplify. First, the noun

partially raises and undergoes PF Merger with the article element in art^0 yielding N-DEF; next, the constituent containing the adjective and artP (= XP in (64)) moves to Spec-DP “to bring about referentiality” (op.cit.:107). Finally, and crucially, “the feature in D is valued by covert movement of the determiner after reconstructing AgrP [= XP] to its base-position” (ibd.). In other words, the article is interpreted high, whereas the A N constituent is interpreted low (in the scope of the determiner), which results in a restrictive interpretation of the adjective.

There is a sense in which this analysis may be considered an OAA insofar as both articles are merged in the same position. However, Roehrs does not attempt to derive DEF from ART (or vice versa), and moreover, he insists on their being different by belonging to different dialects, “Common” and “Literary” Icelandic, respectively. Also such an approach must assume that certain semantic aspects are confined to a certain dialects. This is indeed what Roehrs (op.cit.:133) seems to suggest: “the adjective in literary Icelandic [...] can only have a non-restrictive reading [...] the adjective in the common pattern is restrictive.” I take this to mean that Roehrs opts for a TAA. Another indication that this analysis is not an OAA in the sense of this thesis is that Roehrs assumes a low base position for the article, below adjectives.

The question we thus arrived at is this: is it possible to maintain an OAA as outlined in section 2.1.1?

2.1.5 The Missing Link (Pfaff 2007, 2009)

The greatest deficiency of basically all analyses that, in one way or another, touch upon the issue of the Icelandic article system is that they, by and large, try to establish a difference between ART vs. DEF, exclusively on the basis of patterns (I) and (II). But note that a contrast between patterns (I) and (II) is not equivalent to a contrast between DEF and ART. This is so due to the existence of pattern (III), which also involves DEF, but which has been ignored in the debate (see section 2.1.3). Recall that, at first glance, examples like (63) above seem to provide a semantic argument against OAA. As soon as pattern (III) is factored in, however, the alleged counterargument turns out to actually be an argument in favour of OAA:

- (65) a. ***svokallaða** afstæðiskenning - **in** (I)
so-called theory-of-relativity - DEF
- b. **hin svokallaða** afstæðiskenning (II)
ART so-called theory-of-relativity
- c. afstæðiskenning - **in svokallaða** (III)
theory-of-relativity - DEF so-called

(Pfaff 2009:44)

Pfaff (2007, 2009) observes the following: Since both patterns (I) and (III) involve DEF, the fact that pattern (III) is fine in (65) shows that pattern (I) cannot merely be bad because of DEF as such, and by extension, that it cannot be DEF alone that governs the adjective's interpretation. Rather, the contrast between (65a) vs. (65c) must be a consequence of the different position of the adjective in patterns (I) and (III). Given that patterns (II) and (III) are both fine in (65b/c), the adjective's position in both those cases reveals a rather interesting correlation: it immediately *follows the article* – disregarding the distinction ART vs. DEF, whereas it precedes the article in the (bad) pattern (I) example. The generalization to be extracted from this observation can be put as follows:²²

(66) *Positional Hypothesis* (Pfaff 2007, 2009)

- (i) It is the **adjective's position relative to the article** (pre-articular vs. post-articular) that is responsible for the interpretation of the adjective, rather than the **article's surface form** (ART vs. DEF).
- (ii) Adjectives immediately following the article element receive a non-restrictive interpretation, adjectives preceding the article element (consequently with a noun intervening) receive a restrictive interpretation.

Thus by paying due attention to the otherwise ignored pattern (III), and by invoking the parameter 'post-articular', not only does (66) make sense of the contrast in (63), it also allows Pfaff (2007, 2009) to develop a novel argument in favour of OAA. Recall from section 2.1.1 that a simple OAA proceeds on the assumption of an underlying [ARTICLE [A N]] configuration; if no movement operation takes place, the article is realized as ART, if the constituent containing the noun moves before the article, it is realized as DEF. Applying this approach to pattern (III), this means that the adjective gets stranded in post-articular position. In other words, what patterns (II) and (III) have in common is that the adjective "stays put" regardless of whether the nominal constituent moves or not. In deriving pattern (I), on the other hand, the adjective moves along. Pfaff proposes that the adjective's staying put vs. its moving along determines its interpretation (non-restrictive vs. restrictive). This is illustrated in the following tree diagrams:²³

²²NB: the generalization is based on patterns (I)-(III), and says nothing about pattern (IV). So strictly speaking, each occurrence of "adjective" in (66) should be replaced by "weakly inflected adjective", and this is how I want (66) to be understood.

²³The label α P for a functional projection hosting adjectives is adopted from Julien (2002). Occasionally, I will use other labels (e.g. β P) without suggesting a theoretical difference. The Greek letters serve as a mere diacritic in cases where I want to emphasize that two adjectives are merged in two different zones.

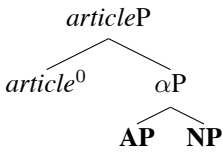
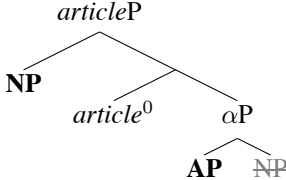
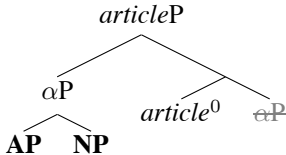
- (67) a.  no movement (II)
adjective stays put
non-restrictive
article → ART
- b.  NP-movement (III)
adjective stays put
non-restrictive
article → DEF
- c.  alphaP-movement (I)
adjective moves along
restrictive
article → DEF

For the purpose of this thesis, I will adopt the general rationale behind (66)/(67) and the basic architectural principles in (67). In particular, I will assume a high base position for the article element, *article*⁰, and phrasal movement to Spec-*articleP*,²⁴ and motivate these assumptions further in the course of the discussion.

I will, however, critically re-evaluate a number of claims and assumptions entailed by (66)/(67). This concerns, amongst other things, the feasibility of the distinction *non-restrictive* vs. *restrictive*, and the nature, size and identity of the moved constituent. The core structure will be outlined in the next subsection, and the properties and interactions of the “weak” patterns (I)-(III) will be discussed in detail in chapter 4.

2.1.6 Core Assumptions

In this subsection, I will briefly establish some formal conventions and technicalities relevant for the discussion to follow; content will be added in the course of the discussion. The naked skeleton structure that I will develop in a stepwise fashion in part I of this thesis can be represented as follows:

²⁴It should be noted, though, that the article element I label DEF behaves more like a proper suffix rather than a phrasal affix (like English genitive *-s*) in that it imposes highly specific restrictions on its host. I will not address these morphological (or possibly morpho-phonological) aspects here.

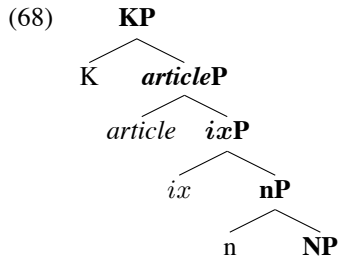

KP is the maximal extended nominal projection in my system and defines a case domain. For simplicity, it will mostly be omitted except for the discussion of pattern (IV); see chapter 3. The specifics of *ixP* (the ‘index phrase’) and *nP* will be established and discussed in chapter 4.

The bulk of the discussion will be dedicated to the article phrase – *articleP* – from various angles; *article* is the merge position of the article and thus the primary locus of the feature [DEFINITE]. For most practical purposes, *articleP* will be synonymous with DP (as used in the literature) although I will consistently use the label *articleP* when merely talking about the article. In cases where I refer to definite determiners more generally, I will use the label DP as a cover term. Although demonstratives will be of secondary importance in this thesis, I will assume a projection *DemP* above *articleP*; so effectively, I assume a DP layer (see (10)/(11) in section 1.1.1):²⁵

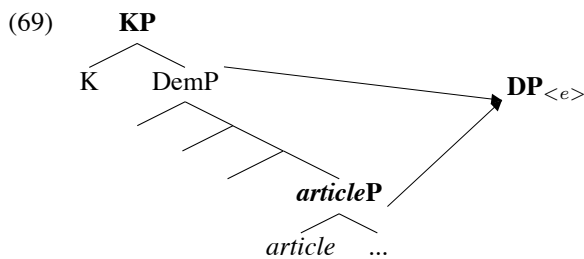

I especially assume that *articleP*/*DP* is the primary locus of reference and the projection that denotes individuals, i.e. objects of type $\langle e \rangle$.

One central goal of the discussion to follow is to show that, in all “slots” between the projections marked in bold-faced in (68), we find various kinds of modifiers with different properties. For expository reasons, I will assume that modifiers are generated as specifiers in designated functional projections, cf. section 1.1.3, as in (70a),²⁶ but I will successively simplify the structures and essentially adopt “telescope” representations as in (70c) (cf. Brody 2000):

²⁵Also recall examples like (62a/b) which involve both a demonstrative and ART; examples of this kind can easily be accommodated in a structure like (140).

²⁶The label αP is adopted from Julien (2002, 2003).

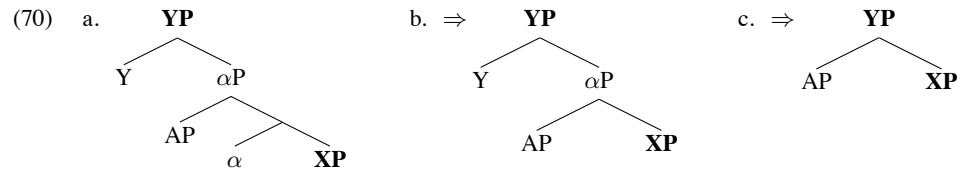

As will be shown, constellations as (70) are not specific to one region in the larger structure. I will, however, assume a fixed position for numeral modifiers and cardinal quantifiers right below *articleP*:²⁷

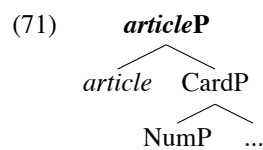

In addition, there are a number of important aspects concerning the status of adjectival inflection; this will be addressed in the next section.

2.2 Adjectival Inflection

As in all Germanic languages (minus modern English), adjectives in Icelandic come with two sets of inflections: the strong and the weak inflection. Both can be viewed as (sets of) portmanteau morphemes expressing (uninterpretable) ϕ /case features with the weak inflection making fewer overt distinctions than the strong one. A schematic overview of the different inflectional endings is given in table 2.3, and for illustration purposes, an example is given in table 2.4:²⁸

²⁷The label CardP is adopted from Julien (2002, 2003).

²⁸'(') indicates that, in this environment, u-umlaut occurs. U-umlaut refers to the phenomenon of an underlying /a/ turning into [œ], spelled <ö>, if it occurs in an initial, stressed syllable, and into [Y], written <u>, if it occurs in a non-initial, unstressed syllable. The label is due to the fact that this process is triggered by an /Y/ (<u>) in the following syllable, cf. the endings *-u* and *-um*. There are, however, environments where u-umlaut takes place even though the original trigger is no longer visible synchronically, and the adjective appears to have a zero ending, cf. STR.FEM.NOM.SG and STR.NEUT.NOM./ACC.PL. Note that the strong MASC.NOM.SG ending does not trigger u-umlaut. It is usually assumed that the [Y] in the ending *-ur* is merely epenthetic and not present underlyingly.

There are some further phonological processes (assimilations, vowel elision etc.) that are not relevant for the present discussion and will therefore not be discussed here.

	STRONG			WEAK		
	MASC	FEM	NEUT	MASC	FEM	NEUT
NOM.SG	-(u)r	-Ø (")	-t	-i	-a	-a
ACC.SG	-an	-a	-t	-a	-u (")	-a
DAT.SG	-um (")	-ri	-u (")	-a	-u (")	-a
GEN.SG	-s	-rar	-s	-a	-u (")	-a
NOM.PL	-ir	-ar	-Ø (")	-u (")	-u (")	-u (")
ACC.PL	-a	-ar	-Ø (")	-u (")	-u (")	-u (")
DAT.PL	-um (")	-um (")	-um (")	-u (")	-u (")	-u (")
GEN.PL	-ra	-ra	-ra	-u (")	-u (")	-u (")

Table 2.3: Strong and weak adjectival inflection

	STRONG			WEAK		
	MASC	FEM	NEUT	MASC	FEM	NEUT
NOM.SG	<i>sval.ur</i>	<i>svöl</i>	<i>sval.t</i>	<i>sval.i</i>	<i>sval.a</i>	<i>sval.a</i>
ACC.SG	<i>sval.an</i>	<i>sval.a</i>	<i>sval.t</i>	<i>sval.a</i>	<i>svöl.u</i>	<i>sval.a</i>
DAT.SG	<i>svöl.um</i>	<i>sval.ri</i>	<i>svöl.u</i>	<i>sval.a</i>	<i>svöl.u</i>	<i>sval.a</i>
GEN.SG	<i>sval.s</i>	<i>sval.rar</i>	<i>sval.s</i>	<i>sval.a</i>	<i>svöl.u</i>	<i>sval.a</i>
NOM.PL	<i>sval.ir</i>	<i>sval.ar</i>	<i>svöl</i>	<i>svöl.u</i>	<i>svöl.u</i>	<i>svöl.u</i>
ACC.PL	<i>sval.a</i>	<i>sval.ar</i>	<i>svöl</i>	<i>svöl.u</i>	<i>svöl.u</i>	<i>svöl.u</i>
DAT.PL	<i>svöl.um</i>	<i>svöl.um</i>	<i>svöl.um</i>	<i>svöl.u</i>	<i>svöl.u</i>	<i>svöl.u</i>
GEN.PL	<i>sval.ra</i>	<i>sval.ra</i>	<i>sval.ra</i>	<i>svöl.u</i>	<i>svöl.u</i>	<i>svöl.u</i>

Table 2.4: *svalur* ‘cool (lit. and fig.)’

The weak inflection employs only three endings to mark 24 gender-case-number values; it does not, for instance, make any distinction in the plural at all. The only unambiguous weak form is masculine nominative singular. The strong inflection, on the other hand, even though it also displays some systematic idiosyncrasies,²⁹ potentially makes 13 distinctions. Although two of the weak endings, *-a* and *-u*, also occur in the strong paradigm, it is never the case that an ending for a given ϕ /case-value is ambiguous between strong and weak. Note further that the weak endings are phonologically simple: they only comprise V-syllables, whereas strong

²⁹Genitive and dative plural make no gender distinction; neuter does not distinguish nominative and accusative; feminine does not distinguish nominative and accusative in the plural. Moreover feminine nominative singular and neuter nominative/accusative plural are always identical, and so are masculine and neuter genitive singular, and masculine accusative plural and feminine accusative singular. Apart from that, six forms are unambiguous.

endings are more varied in that respect: we find V-, C-, VC-, CV-, and CVC-syllables.

2.2.1 Distribution

The strong adjectival inflection may be considered the default insofar as it has the widest distribution. Strongly inflected adjectives occur as syntactic predicates in various contexts, cf. (72a/b) and as adjectival modifiers in indefinite noun phrases, cf. (72c). Adjectival predicates agree in case, number and gender with their subject, cf. (72a/b):

- (72) a. PRIMARY (COPULAR) PREDICATION
- i. minning.ar eru falleg.ar
memories.NOM (f) are beautiful.STR.NOM.PL.FEM
 - ii. strákurinn er ung.ur
boy.the.NOM is young.STR.NOM.SG.MASC
- b. SECONDARY PREDICATION
- i. strákurinn kom blindfull.ur heim
boy.the.NOM came blind-drunk.STR.NOM home
 - ii. ég sá strákinn blindfull.an
I saw boy.the.ACC blind-drunk.STR.ACC
- c. INDEFINITE NOUN PHRASES
- i. gul.ur bíll
yellow.STR car
'(a) yellow car'
 - ii. (fimm) gul.ir bílar
five yellow.STR cars

The weak inflection, on the other hand, has a very restricted distribution: weakly inflected adjectives only occur *adnominally* in *definite noun phrases*, notably when following a definite determiner:

- (73) a. gul.i bíll - **inn**
yellow.WK. car - DEF
- b. **þessir** gul.u bílar
these yellow.WK. cars
- c. **hið** fagr.a
ART beautiful.WK
- d. **minn** gaml.i vinnufélagi
my old.WK workmate

Given these distributional properties, we expect the weak inflection to be banned from predicate positions and indefinite contexts, and the strong inflection from definite contexts. By and large, this is the case:³⁰

³⁰As for (74b), note that A.WK N is not ungrammatical per se, for there are two contexts where

- (74) a. *strákurinn er ung.i
boy.the is young.WK
- b. *gul.i bíll
yellow.WK car
- c. *þessir gul.ir bílar
these yellow.STR cars
- d. *minn gamal.I vinnufélagi
my old.STR workmate

Because of contrasts like (72c) vs. (73), also (74b/c), some authors associate weak and strong inflection directly with definiteness and indefiniteness, respectively, and, accordingly, talk about *definite inflection* and *indefinite inflection*. As a matter of nomenclature, this is a trivial issue, but if the terminology is to be contentful, it is problematic.

2.2.2 Adjectival Inflection – Morphology or Semantics?

As a point of departure, we might assume two features [STRONG] and [WEAK] that can be viewed as semantically contentful or as a purely morphological/morpho-syntactic phenomenon, i.e. as interpretable or uninterpretable.

Julien (2005a), for instance, explicitly argues against the notion of weak inflection “as a ‘dummy’ inflection without any semantic content” (op.cit.:44), and in favour of “the **(in)definiteness** of the adjective, and hence of the DP as a whole” (op.cit.:248), and (Julien 2005b:242) claims that “[i]n the absence of marking on the noun it is the **indefinite form of the adjective** that shows that **these DPs are indeed indefinite**” (emphasis mine).³¹ These statements seem to indicate that Julien indeed associates adjectival inflection with (in-) definiteness, and especially, strong adjectival inflection with indefiniteness of the DP. In a similar vein, Lohrmann (2008, 2010) proposes that (weak) adjectival inflection contributes a semantic feature [IDENTITY].³²

we find this constellation, in a direct address (“vocative”), and in the context of names:

- (1) a. kær.i vinur
dear.WK friend
- b. Gamli.i garður
old.WK garden
(name of a students’ dormitory in Reykjavík)

One way or another, however, such contexts are more properly characterized as definite rather than indefinite in spite of their lacking an overt determiner. I will not discuss examples of this kind here.

³¹The last two quotations from Julien actually make reference to possessed DPs which will be the topic of chapter 5.

³²In addition to the proposals just mentioned, we find rather different approaches to the issue of adjectival inflection such as Leu (2008); Katzir (2011) (also the reply to the latter in Norris et al. 2013). For the purpose of this thesis, I do not attempt to assess whether/how all those analyses can account for the data presented here, or to what extent they are compatible with my proposal.

There are several problems, with these assumptions. If strong inflection is semantically contentful or interpretable, it is not immediately obvious what this would mean for adjectival predicates as in (72a/b). Note further that adjectival predicates are strongly inflected regardless of whether their subject is definite or indefinite. It therefore seems that at least the strong inflection should not itself be specified with respect to definiteness; I more generally conclude that strong inflection itself has no semantic content, and if there is a feature like [STRONG], it cannot be an interpretable one. But another problem arises with [STRONG] as an uninterpretable feature; given that – one way or another – uninterpretable features must be checked, licensed, or valued, it is far from obvious what could be a potential suitable licenser that covers both adnominal and predicative uses of adjectives.

Now, as for weak inflection, things look different. The above examples clearly indicate that weak inflection only occurs under specific conditions: (i) in adnominal position (ii) in the context of definiteness. This suggests that (definite) determiners are ideal licensers. I will assume that there is indeed a feature [WEAK] that needs licensing by some feature [DEFINITE] (contributed by definite determiners like articles or demonstratives). To put it somewhat differently: weak inflection is triggered in the context of definiteness. As for the strong inflection, it seems as though we can only give a negative characterization: an element shows up strongly inflected precisely *when the weak inflection is not triggered*. Thus there is no need for a feature like [STRONG]. Strong inflection can be viewed as the elsewhere case, the natural state of affairs, as it were. In other words, grammar does not recognize “strong” inflection; what we call strong inflection is simply the default spell-out of (ϕ /case) agreement features that shows up in any well-formed (adjectival) environment – except for one specific scenario: when the weak inflection is triggered.

Implicitly I have already answered the final open question – does [WEAK] make a semantic contribution, i.e. is it interpretable? – in the negative. For the purpose of this thesis, I do not assume that [WEAK] expresses definiteness in a semantic sense. It can be seen as *reflecting* definiteness that is marked somewhere else, namely wherever the feature [DEFINITE] is located. (Vangsnes 1999b:118) suggests that “definite adjectival inflection may be considered *agreement* with the feature [deix]” and this is the conception I will adopt for the relationship between [DEFINITE] and [WEAK]. More precisely, I will assume that the two stand in a c-command relation.

Summarizing, then, the relevant generalization can be stated as follows:

- (75) a. If the adjective is c-commanded by [DEFINITE], the weak inflection is triggered (→ [WEAK] must be licensed by a c-commanding feature [DEFINITE])³³

³³Strictly speaking, this process is better understood as a partial valuation mechanism in that [DEFINITE] values some feature on AP as [WEAK] which is spelled out as weak inflection. If that valuation does not take place, it is spelled out as strong inflection.

- b. If weak inflection is not triggered, the adjective occurs strongly inflected
 (→ there is no feature [STRONG])
 (→ strong inflection is not triggered; elsewhere condition)

There are a number of technical details regarding (75a) that I will not address here in detail. I will mostly be interested in the predictions that (75) makes. Trivially, weak inflection is not triggered in predicative contexts and in indefinite noun phrases. Thus examples like (72) receive a natural and simple account that does not require any additional assumption (at least as far as adjectival inflection is concerned). When it comes to pattern (IV), however, (75a/b) make a rather extraordinary prediction.

2.2.3 Inside and Outside *articleP*

Recall from the introduction to this chapter (see examples (40a/d) and table 2.1) that the only visible difference between patterns (I) and (IV) is adjectival inflection:

- (76) a. full.i strákur - inn (I) b. full.ur strákur - inn (IV)
 drunk.WK. boy - DEF drunk.STR. boy - DEF

Recall further that, given my analysis as sketched in 2.1.5, pattern (I) is derived from a constellation in which the article element c-commands the adjective. On the reasonable assumption that the article contributes [DEFINITE], this is precisely the constellation required for the triggering of the weak inflection according to (75a):

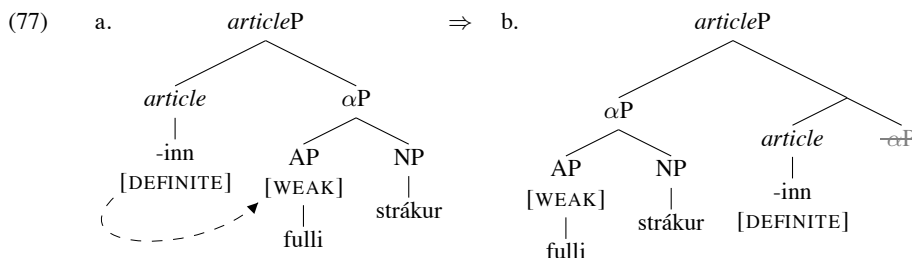

The same reasoning applies to patterns (II) and (III), thus the weak inflection in the “weak” patterns is straightforwardly accounted for. We must, however, rely on the assumption that [WEAK] is licensed before movement takes place as in (77a). Otherwise the derivation of pattern (I) would crash, for, in (77b), the adjective (and thus [WEAK]) is no longer c-commanded by [DEFINITE].

But now the question arises how to account for pattern (IV). Assuming, as I will, that (75) is valid and applies rigidly, examples like (76b) are *prima facie* completely unexpected – at least as long as we assume that the adjective is really merged in a position below the article on a par with (77). The other way of looking

at things is that the pattern (IV) modifier is never c-commanded by [DEFINITE] to begin with because it is merged **outside** *articleP*. Then pattern (IV) can simply be subsumed under the elsewhere case: the weak inflection is *not* triggered on the respective adjective, and therefore it shows up with the default strong inflection. The basic structure I propose for examples like (76b) and pattern (IV) in general is this:³⁴

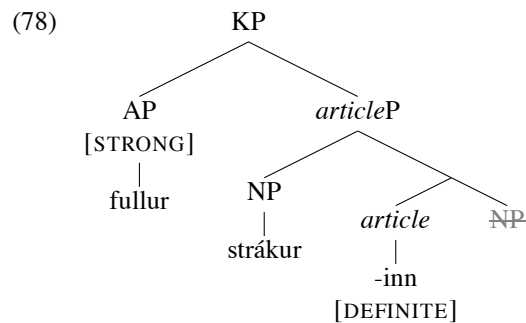

Here patterns (I) and (IV) primarily differ in their structure, whereas the difference in inflection is merely a concomitant of the structural position of the respective adjective: inside vs. outside *articleP* (that is, c-commanded by [DEFINITE] vs. not c-commanded by [DEFINITE]). Conversely, the adjective's inflection can be viewed as an indicator in the sense that it gives a clue as to the adjective's position:

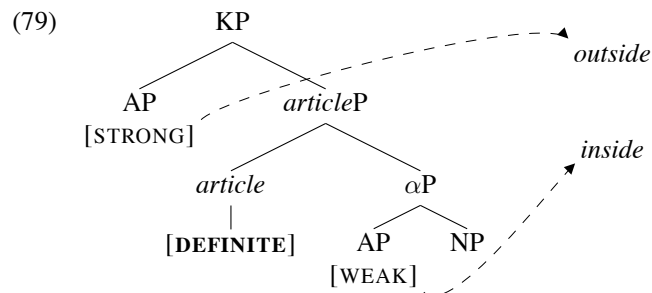

Note that the four patterns by definition involve a definite article; therefore, in most cases, I will naturally talk about *articleP* when talking about the definiteness domain. However, I want the concept to be understood more broadly. In particular, I will show that what was said above also applies to demonstratives (that also carry the feature [DEFINITE]). In cases that concern both the article and demonstratives, I will use the label DP (see section 2.1.6).

³⁴ A note of caution: even though I assume that strong inflection is not featurally marked, I will use the label “[STRONG]” as in (78) for expository convenience.

The structural distinction suggested by the proposal reveals a genuine insight in the architectural nature of the Icelandic noun phrase. It also allows us to approach a range of semantic issues from a new perspective and give a unified account of apparently unrelated phenomena. The idea that adnominal adjectives are inside the DP is the uncontroversial default assumption, and does not need any particular justification. What does need justification is the claim that certain adnominal modifiers are outside the DP in a real sense, and that the distinction *inside* vs. *outside* correlates with the distinction WEAK vs. STRONG (in the context of definite noun phrases). This will be the purpose of chapter 3.

A final observation: In those cases where we find both strongly and weakly inflected elements in the same definite DP, i.e. a joint pattern (I/IV), the expectation according to (75) and (79) is that we only find the ordering is [STRONG] >> [WEAK], without exception. This is indeed what we find:

- (80) a. Bölvæð.úr gaml.i níðingur - inn!
 cursed.STR old.WK scoundrel - DEF
 (~ 'the bloody bastard')
- b. á öndverð.um sjött.a áratug - num
 on beginning.STR sixth.WK decade - DEF
 'in the beginning of the 50s'
- c. mörg. dýrmætust.u handrit - in
 many.STR most-precious.WK manuscripts - DEF
 'many of the most precious manuscripts'

The order [WEAK] >> [STRONG] is categorically bad:

- (81) a. [?]blessað. blessað.a vatn - ið!
 blessed.STR blessed.WK water - DEF
 'the damn blessed water' (uttered perhaps by some diabolic creature)
- b. *blessað.a blessað. vatn - ið!
 blessed.WK blessed.STR water - DEF

This observation may not in and of itself be a solid proof for my claim, but it does corroborate it to a certain extent. More evidence and stronger arguments will be provided in the next chapter.

Chapter 3

Strong Adjectives: Pattern (IV)

The discussion of what I call pattern (IV), i.e. strongly inflected adjectives in the context of definite noun phrases, typically focuses on modifiers that are classified as adjectival appositives (*lýsingarorðsviðurlög*) in the Icelandic grammatical tradition, a fact that is not always appreciated in the non-Icelandic literature. I will adopt the term for the discussion to follow, and refer to the respective strongly inflected adjective as *pattern (IV) appositive*. It is crucial, however, to emphasize that pattern (IV) appositives are not necessarily identical to *appositive adjective* or *adjectival appositive* that have been discussed in the literature in the context of other languages or constructions. The discussion will largely proceed on the assumption that pattern (IV) appositives are first and foremost an Icelandic phenomenon.

This chapter will, for the most part, be dedicated to a detailed examination of pattern (IV) appositives. I will point out a number of properties and peculiarities that have not been noted in the literature, and discuss some analytical options. In addition, I will show that there are other kinds of elements that can formally be described as pattern (IV) modifiers, such as expressives, positional predicates, and certain partitive quantifiers.

The central goal of this chapter is to show that all those various pattern (IV) modifiers provide evidence for the claim set forth in section 2.2 that the strongly inflected element in pattern (IV) noun phrases is merged *outside the definite noun phrase*, i.e. above *articleP* (DP). En passant, I will point out a number of differences between pattern (IV) and the weak patterns.

3.1 Appositive Adjectives

Pattern (IV) appositives necessarily have a predicative reading and a literal meaning, and they may be paraphrased by a non-restrictive relative clause or some other kind of clause such that the adjective occurs as the syntactic predicate (in postcopular position) in that clause:

- (82) a. Ég horfði upp í blá.an himin - inn (Thráinsson 2007:3)
 I looked up in blue.STR. sky - DEF
 ‘I looked up into the sky, which happened to be blue (at that moment)’
- b. Blindfull.ur strákur - inn kom heim (Rögnvaldsson 1984:61)
 blind-drunk.STR. boy - DEF came home
 ‘The boy came home and he was blind-drunk (when he came home)’
- c. Ég sá blindfull.an forstjóra - nn (Rögnvaldsson 1984:68)
 I saw blind-drunk.STR. director - DEF
 ‘I saw the director, who BTW was blind-drunk’
- d. Æst.ur skrill - inn ruddist inn í húsið
 enraged.STR. mob - DEF jostled in into house.the
 ‘The mob, who were in a rage, stormed the house’
- e. Hann kastaði bókinni út um opin.n glugga - nn
 He threw book.the out about open.STR. window - DEF
 ‘He threw the book out through the (currently) open window /
 out through the window, which BTW was open (at that moment)’
- f. Hann rann á hál.u gólfi - nu
 he skidded on slippery.STR. floor - DEF
 ‘He skidded (and fell) on the floor, which happened to be slippery’
- g. Hún rölti um tóm.ar götur - nar
 she strolled about empty.STR streets - DEF
 ‘She strolled around the streets, which were empty’

Inherently non-predicative and non-subjective adjectives including thematic nationality adjectives,¹ on the other hand, cannot be used in pattern (IV) at all:

- (83) a. *svokölluð afstæðiskenning - in
 so-called.STR theory.of.relativity - DEF
- b. *meint.ur þjófur - inn
 alleged.STR thief - DEF

¹Predicative and thematic readings of nationality adjectives will be discussed in section 4.2.1. Actually, nationality adjectives seem to be generally bad in pattern (IV) even in cases where they potentially allow a predicative reading: ✗ *fransk.ur ferðamaður-inn* ‘French.STR tourist-DEF’ (average score: 0.23).

- c. *fransk.ur forseti - nn
 French.STR president - DEF
 (intended meaning: ‘the president of France’)

Before continuing, it is crucial to emphasize that pattern (IV) itself really is a nominal constituent rather than, say, some kind of small clause with two independent constituents being adjacent. Generally, pattern (IV) DPs have the distribution of argumental noun phrases. Moreover, Rögnvaldsson (1984) points out that Icelandic being a V2 language requires that only constituents occupy the preverbal position. While, in English, we may find examples like (84a) where the initial adjective is a secondary predicate that has been topicalized, such that adjective and DP do not form a constituent in spite of their being adjacent, the basically parallel *surface* order in Icelandic cannot be parsed that way, see (84b).² Here adjective + DP necessarily form a constituent, namely the subject. The same goes for topicalized pattern (IV) objects, as illustrated in (84c); due to the V2 constraint, we find subject-verb inversion (example (84c) is taken from Rögnvaldsson 1984:69):

- (84) a. [Dead-drunk] [the boy] came home
 b. [Blindfull.ur strákur - inn] **kom** heim
 [dead-drunk.STR boy - DEF]-NOM came home
 c. [Blindfull.an forstjóra - nn] **sá** ég hér í gær
 [dead-drunk.STR director - DEF]-ACC saw I here yesterday

In a nutshell, pattern (IV) as a whole behaves like a nominal constituent, not like a clausal constituent. Before addressing the internal make-up of this nominal constituent itself, I will point out a number of semantic properties of pattern (IV) appositives.

3.1.1 Absence of Restrictivity

Consider the following well-know minimal pair:

- (85) a. gul.i bíll - inn (I) b. gul.ur bíll - inn (IV)
 yellow.WK. car - DEF yellow.STR. car - DEF

(Árnason 1980:44) uses these examples to illustrate the difference between attribute and appositive: the former narrows down the meaning of the noun denotation, the latter does not. (Delsing 1993:132, fn. 25) mentions this example

²Due to the V2 constraint, in the Icelandic version of (84a), the adjective and the DP are not even adjacent:

- (1) [Blindfullur] **kom** [strákurinn] heim
 dead-drunk came boy.the home

(as reported in Rögnvaldsson 1984:59/60) and points out that only the weakly inflected adjective can have an identifying function and restrictive reading, whereas the strongly inflected adjective can only have a non-restrictive reading: “If a noun phrase of the type [the yellow car] is not meant to identify ‘the yellow car’, but only to identify a car, which happens to be yellow, Icelandic marks this with the strong form of the adjective.” This footnote has been interpreted in a number of rather interesting ways. For instance, (Cinque 2010:140/1, fn. 1) reasons as follows: “If non-restrictive modifiers are only direct modifiers and restrictive ones only indirect modifiers derived from a reduced relative clause source, then Icelandic [...] distinguishe[s] the two sources overtly” (for the notions *direct/indirect modifiers* see sections 1.2.2 and 1.2.3). Thus he implicitly proposes the following correlation:

- (86) strongly inflected adjective/pattern (IV) modifier \Leftrightarrow DM
 weakly inflected adjective/pattern (I) modifier \Leftrightarrow IM/RRC

This equation is problematic in many respects, which I will come back to in 3.1.4 below. Here I would like address a particular issue: the conflation of appositive and non-restrictive readings. Recall the definitions for restrictivity and non-restrictivity from section 1.2.1:

- (87) a. an adjective A **restrictively** modifies N in c iff
 $\llbracket \mathbf{AN} \rrbracket^c \subset \llbracket \mathbf{N} \rrbracket^c$ (i.e. $\exists x: x \in \llbracket \mathbf{N} \rrbracket \ \& \ x \notin \llbracket \mathbf{AN} \rrbracket$)
 b. an adjective A **nonrestrictively** modifies N in c iff
 $\llbracket \mathbf{AN} \rrbracket^c = \llbracket \mathbf{N} \rrbracket^c$ (i.e. $\forall x: x \in \llbracket \mathbf{N} \rrbracket \rightarrow x \in \llbracket \mathbf{AN} \rrbracket$)

Pattern (IV) appositives most certainly are not restrictive under any useful definition. In section 1.2.1, I pointed out that, at least according to definitions like (87), non-subjective adjectives like ‘alleged’ are also most appropriately classified as not restrictive (rather than non-restrictive). However, as suggested by (83), pattern (IV) appositives should not be classified with non-subjective adjectives for independent reasons. As for non-restrictivity, on definitions like (87b), the bare noun denotation and the modified noun denotation are construed as co-extensive sets, that is, sets that have exactly the same members. I argue that pattern (IV) appositives should not be classified as non-restrictive in this sense, either, most notably because the “modifiee” is not a set-denoting expression ($\langle e, t \rangle$), but an individual ($\langle e \rangle$).

As, at least partially, suggested by the paraphrases of examples in (82), the adjective conveys separate information about an independently identifiable referent. For other appositive modifiers like PPs (even though they are often referred to as non-restrictive), it has indeed been noted that “they have the status of separate sentences which serve to make side-remarks of some kind” (Heim and Kratzer 1998:64), and appositive relative clauses, for the same reason, have often been

analysed as adjoined to DP rather than to NP. The intuition behind this kind of analysis is this: if DP is the locus of referential expressions, then anything that is merged outside DP can have no impact on the reference of that expression.

In section 2.2.3, I proposed that strongly inflected elements cannot be c-commanded by a definiteness morpheme, which is why pattern (IV) modifiers should be analysed as being merged outside *articleP*. This analysis independently motivated on morpho-syntactic grounds naturally brings about the required constellation for appositive modifiers:

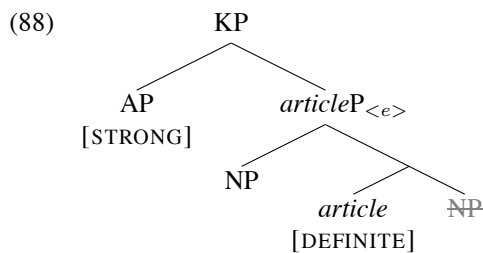

Given that *articleP* is the locus where reference is determined, adjectives that are merged outside cannot have any impact on the reference. Note in particular that the adjective (88) combines with an expression of type $\langle e \rangle$, not with a set-denoting expression (like NP). Therefore, neither definition in (87) applies, which suggests, especially, that pattern (IV) modifiers are not non-restrictive.

Interesting independent evidence for the idea that appositive modifiers are merged outside *articleP*, or outside DP more generally, comes from Chinese. (Sproat and Shih 1991:574/5) show that indirect modifiers, i.e. DE-modifiers (see section 1.2.2), may “occur either inside or outside specifiers”, where “specifier”, in current terminology, means “determiner” (or DP). This *outside* vs. *inside* distinction is overtly marked: in the former case, the DE-modifier precedes the determiner, in the latter case, it follows it. In addition, there is a semantic correlation: those modifiers occurring outside are appositive, but the ones occurring inside are restrictive. For the examples in (89a/b), the authors give the semantic representations in (90a/b) (their examples (26a/a’) and (27a/a’)):

- (89) a. [hóng -de] zhèiběn shū zài zhuōzi shàng
 [red -DE] this book at table on
 b. zhèiběn [hóng -de] shū zài zhuōzi shàng
 this [red -DE] book at table on
- (90) a. [this x | book’(x)] _{j} is on the table & it _{j} is red (appositive)
 b. [this x | (book’(x) & red’(x))] is on the table (restrictive)

We observe two things: First of all, in the a-examples, the modifier precedes the determiner and is appositive. This is exactly identical to my analysis of pattern (IV) appositives, cf. (88). Secondly, in the b-examples, the modifier follows the determiner and is restrictive. This largely coincides with my analysis of pattern (I) as sketched in section 2.2.3 (of course, the constellation as such is the one I propose for the weak patterns in general). At any rate, the same contrast as in (89)/(90) can be reproduced with patterns (I) vs. (IV):

- (91) a. full.ur strákur - inn (IV)
 drunk.STR boy - DEF
 [THE x | boy'(x)]_k & drunk'(he_k) (appositive)
- b. full.i strákur - inn (I)
 drunk.WK boy - DEF
 [THE x | boy'(x) & drunk'(x)] (restrictive)

The determiner *zhèiběn* in (89) can be seen as a boundary of the DP which makes the notions *inside* and *outside* more transparent: modifiers that precede the determiner, and are thus visibly outside the DP, semantically correspond to pattern (IV) appositives, whereas those that follow the determiner and are thus visibly inside the DP correspond to weakly inflected pattern (I) adjectives. For patterns (I) vs. (IV) themselves, however, this boundary is not visible on the surface. Instead, I have proposed that the adjectival inflection indirectly reflects the adjective's underlying position with respect to the DP boundary:

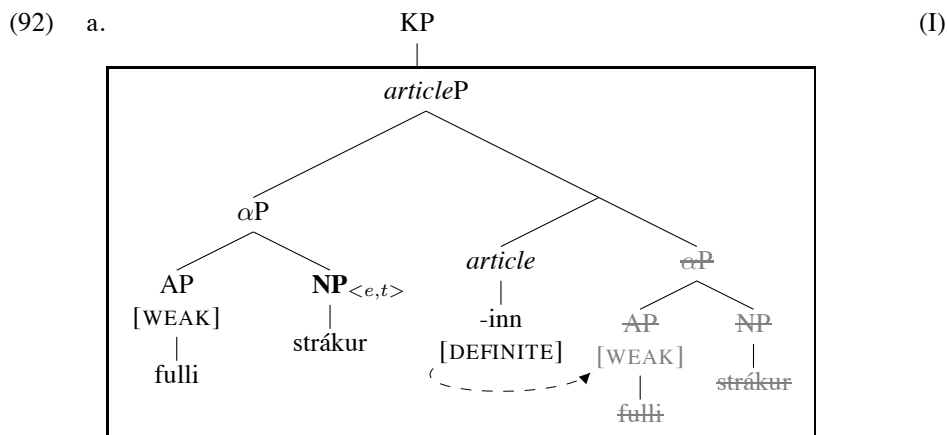

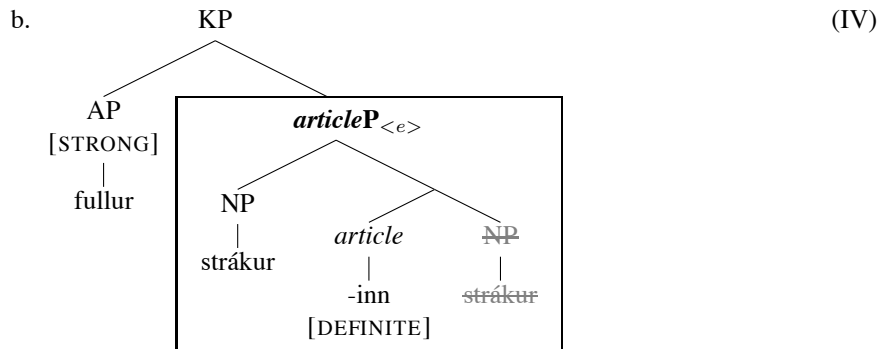

3.1.2 Adverbiality and Freedom from Attitude

It has been suggested that pattern (IV) appositives may be characterized as denoting a temporary property of the respective DP referent, in other words as stage level (SL) predicates.³ When only looking at the examples in (82), this indeed appears to be a valid assessment; after all, adjectives like ‘drunk’ and ‘enraged’ are textbook examples of SL predicates, and a window’s being open or the floor’s being slippery is normally understood as a transitory state that holds at a certain time. This aspect is, however, a mere side-effect, not a defining characteristic of pattern (IV) appositives. Notably, not all adjectives can be construed as SL predicates:

- (93) a. *Pau komu út úr kolsvart.ri nótt - inni*
 they came out of pitch-dark.STR night - DEF
- b. *Hann valt niður snarbratt.a hlíð - ina*
 he rolled down precipitous.STR slope - DEF
- c. *Hann rann á hál.um ís - num*
 he skidded on slippery.STR ice - DEF

Adjectives like ‘precipitous’ are normally understood to denote a permanent or individual level (IL) property; indeed (93b) does not suggest that the slope may have been non-precipitous at some other time. Particularly revealing is the minimal pair (82f) vs. (93c); while it seems, in principle, feasible to construe *being slippery* as a temporary property or transitory state with respect to a floor, this is not possible with respect to ice – ice is slippery as long as it is ice. In this sense, *slipperiness* is actually an IL property of ice. Nonetheless, the intuition that temporariness is somehow involved is not entirely wrong. It is merely that the SL/IL distinction is not the actual issue.

³At least, (Rögnvaldsson 1984:61) hints at that possibility that “... some kind of temporal meaning emerges” in the context of pattern (IV) appositives.

There are two things to consider: On the one hand, instead of talking about *temporary properties* and transitory states of a referent, it is perhaps more suitable to talk about *accidental* or *potential properties* and *circumstantial aspects* of a referent. Pattern (IV) appositives highlight a property of a referent in a certain situation (irrespective of whether it also holds at other moments or not). Evidence for this characterization – highlighting circumstantial aspects – can be drawn from the fact that pattern (IV) appositives can typically be paraphrased by various kinds of adverbial clauses:⁴

- (94) a. Ósýnileg.ar stjörnur - nar vörpuðu svolitlu ljósi aftan á skýin
invisible.STR stars - DEF cast some light from-behind on clouds.the
'The stars – *even though* they were invisible at that moment / *even though* we couldn't see them – cast some light on the clouds from behind'
- b. Setja skal smokkinn á stíf.an lim - inn
put shall condom.the on stiff.STR penis - DEF
'... *while/when* it is hard'
- c. Rauð.ur bíll - inn sást vel á dökk.u slitlagi - nu
red.STR car - DEF was-seen well on dark.STR paving - DEF
'*Because* the car was red, it could be seen well ...'
- d. Hann rann á hál.u gólfi - nu / á hál.um ís - num
he skidded on slippery.STR floor - DEF / on slippery.STR ice - DEF
'He skidded (and fell) on the floor/ice *because* it was slippery

On the other hand, the additional piece of (circumstantial) information supplied by the pattern (IV) appositive really is the speaker's comment about the referent. (94), for instance, could just as well be paraphrased like this:

- (95) Assertion: The stars cast some light on the clouds from behind
Comment: BTW, the stars/they were not visible (at that moment)

The comment function can be illustrated beautifully in cases where the relevant noun phrase is embedded under an attitude operator such as the verb 'believe':

- (96) Pattern (IV) noun phrase under attitude
- a. Jón hélt að hann gæti dansað á hál.u gólfi - nu
Jón believed that he could dance on slippery.STR floor - DEF
- b. Jón hélt að hann gæti skotið fuglinn með óhlaðin.ni byssu - nni
Jón believed that he could shoot bird.the with unloaded.STR gun - DEF

⁴Thanks to Höskuldur Thráinsson (p.c.) for (94a); (94b) is taken from a somewhat redundant instruction leaflet; (94c) is taken from Thráinsson (2001). To my knowledge, this adverbial connotation has not been noticed before, but all my informants confirmed this intuition.

Both examples in (96a/b) are fine in a range of contexts where Jón may have known/believed certain things or not. In particular, even if he did not know (and hence not believe) that the floor was slippery, (96a) is felicitous precisely because the information conveyed by the adjective here is not part of the reported belief; it is a comment by the speaker. In other words, in spite of the adjective being (syntactically) embedded under attitude, it is not bound by attitude. It may convey information about facts unbeknownst to the attitude holder.

If we look at the behaviour of the corresponding pattern (I) noun phrases in the same context, we find a striking difference:

(97) Pattern (I) noun phrase under attitude

- a. Jón hélt að hann gæti dansað á hál.a gólfi - nu
 Jón believed that he could dance on slippery.WK floor - DEF
- b. Jón hélt að hann gæti skotið fuglinn með óhlöðn.u byssu - nni
 Jón believed that he could shoot bird.the with unloaded.WK gun - DEF

Examples (97a/b) are infelicitous if Jón did not even know that the floor was slippery/the gun was not loaded; they are fine only if his explicit beliefs are “I can dance on the *slippery* floor” or “I can shoot the bird with the *unloaded* gun”, respectively. Thus the information conveyed by the embedded weakly inflected adjective must be a part of the reported attitude.

3.1.3 Temporal/Anaphoric (In-) Dependence

Musan (1995, 1999) shows that presuppositional noun phrases may be *temporally independent*,⁵ whereas non-presuppositional noun phrases are temporally dependent,⁶ where definite and partitive noun phrases are presuppositional, indefinite and cardinal noun phrases are non-presuppositional; consider the following example:

(98) [Talking about students' progress]

- a. Weak noun phrases under their partitive reading:
 SOME *college students* were lazy in highschool
- b. Weak noun phrases under their cardinal reading:
 #Some COLLEGE *students* were lazy in highschool

(Musan 1999:634/5)

⁵The observation as such was already made by Enç (1981, 1986).

⁶“A noun phrase occurrence is temporally dependent if and only if its situation time has to intersect with the situation time of the main predicate of its clause. A noun phrase occurrence is temporally independent if and only if its situation time does not have to intersect with the situation time of the main predicate of its clause” (Musan 1999:622).

Given that college students are no longer highschool students, *college student* and *be lazy in highschool* cannot be simultaneously predicated of the same referent. Nonetheless, only (98b) is pragmatically deviant by suggesting that some individuals were simultaneously college students and in highschool. (98a), on the other hand, is fine; the reading we (implicitly) get is that some individuals that are college students at some relevant time t_1 were lazy at some time t_2 (i.e. while in highschool). This is what temporal independence means.

The quintessence of Musan's analysis is that it is the semantic properties of the determiner heading the noun phrase that "decides" whether that noun phrase may be temporally independent or not. Pfaff (2015) and Rapp (2014) show that this distinction also applies to adnominal participle phrases in indefinite vs. definite noun phrases in German (see also Kusumoto 2000 for English):

- (99) a. ein tanzender Mann saß an der Bar
 a dancing man sat at the bar
 b. der tanzende Mann saß an der Bar
 the dancing man sat at the bar

Pfaff (2015)

Example (99a), where the participle is a constituent of an indefinite DP, only has the pragmatically odd reading that some man was simultaneously dancing and sitting at the bar. Both the participial event DANCE and the matrix event SIT-AT-THE-BAR make reference to the same sentence topic time. This simultaneity effect, however, is not due to the participle semantics, but to the indefiniteness of the DP. For if the participle is embedded in a definite DP, it becomes more flexible: (99b), when properly contextualized, can easily mean that a certain man was dancing at some time t_1 , but sitting at the bar at t_2 . Imagine the following narrative background:

- (100) a. [... I entered the house and looked around. One single man was dancing to the crazy beats that came hammering out of the speakers. I went to check out the buffet ... when I came back again ten minutes later, the dance floor was completely empty and...]
 b. ... der tanzende Mann saß an der Bar
 'the dancing man was (now) sitting at the bar'

With this in mind, consider the pattern (I) and (IV) versions of the noun phrase 'the drunk boy' from (91) in three slightly differing scenarios; suppose the speaker is describing the events at a party:

- (101) [CONTEXT A: ... one of the guests, some **boy** I didn't know, was really annoying ... I was talking to a friend when ...]

... full.ur / #full.i strákur - inn réðst á mig
 ... drunk.STR / drunk.WK boy - DEF attacked on me

- (102) [CONTEXT B: ... one of the guests, some **drunk boy** I didn't know, was really annoying ... I was talking to a friend when ...]

... full.i / full.ur strákur - inn réðst á mig
 ... drunk.WK / drunk.STR boy - DEF attacked on me

The pattern (I) version in (101) is infelicitous, or, at least, deviant because it tries to identify a “drunk boy”, but the discourse domain only contains a “boy”. The (IV) version, on the other hand, is basically fine. It does not identify a referent as “drunk boy”, but makes reference to a certain “boy” and comments on a circumstantial aspect: “the boy attacked me; BTW, he was drunk (when he attacked me).” If the discourse domain does contain a referent that has been introduced as “drunk boy”, as in (102), both (I) and (IV) are fine, but they still display the subtle difference *identification of a referent* vs. *description of circumstances*. But now see what happens when the boy's being drunk and his attacking the speaker are presented as occurring at different times:

- (103) [*continuation of* CONTEXT B: ... two days later I went back there. I had hardly entered the house when ...]

... full.i / #full.ur strákur - inn réðst aftur á mig
 ... drunk.WK / drunk.STR boy - DEF attacked again on me
 (þótt hann væri allsgáður núna)
 (although he was sober now)

This last scenario is similar to example (99b), insofar as two different events occur at two different times: the boy being drunk (at the party) and him attacking the speaker (two days later). Pattern (IV) is bad in this context; only the pattern (I) noun phrase is felicitous here, i.e. only the weak adjective may be considered temporally independent in Musan's sense.

Instead of talking about temporal (in-) dependence, we can cast this observation more broadly in terms of (discourse) reference. The weak adjective adds descriptive content to the noun phrase, and in this, it contributes to identifying the unique referent in the discourse domain (or the “common ground”) that fits the description “drunk boy”. On my assumption that *articleP* is the locus of reference and relevant descriptive content is established inside *articleP*, it is expected that weak adjectives – which are merged inside *articleP* – do contribute to the referentially relevant description.

But by the same token, we expect (strongly inflected) pattern (IV) modifiers – which are merged outside *articleP* on my account – not to contribute descriptive content that is referentially relevant. As a matter of fact, this already follows from what was said in section 3.1.1 about the “not restrictive” reading of appositives: pattern (IV) appositives are not restrictive because they do not combine with a set-denoting nominal expression ($\langle e,t \rangle$), but an individual ($\langle e \rangle$), an independently established referent.

3.1.4 Reduced Relative Clauses

The examples discussed in section 3.1 suggest that pattern (IV) appositives can always be paraphrased by some (relative, adverbial, conjunct) clause. It seems therefore reasonable to ask whether they can actually be construed as comprising clausal structure. A possible representation could be the following:

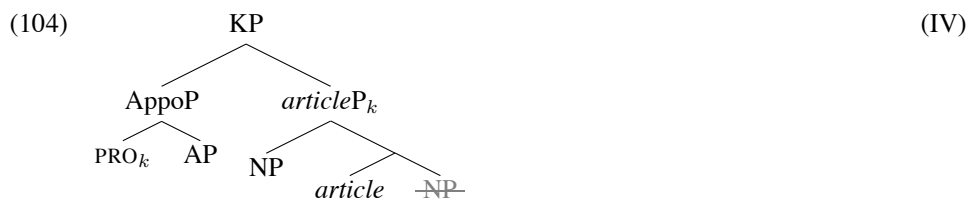

In sections 1.2.2, I discussed the widespread idea that certain adjectives really are reduced relative clauses (RRCs). Among the most recent and influential proponents of this idea is Cinque (2010), see section 1.2.3, who argues that adnominal adjectives have two sources: a direct modification (DM) source, and an indirect modification (IM) source. Adjectives generated in the latter, are RRCs. Moreover, he proposes that each source is associated with a respective set of semantic properties, some of which are given below (see table 1.2 on page 18):

INDIRECT MODIFICATION/RRC	DIRECT MODIFICATION
stage (or individual) level	individual level
intersective	non-intersective
restrictive	non-restrictive
only literal interpretation	possibly idiomatic
only predicative	possibly non-predicative

Table 3.1: *Indirect and direct modification*

Recall from section 3.1.1 that, with reference to Delsing (1993), (Cinque 2010: 140/1, fn. 1) suggests the following correlation:

- (105) strongly inflected adjective \Leftrightarrow DM
 weakly inflected adjective \Leftrightarrow IM/RRC

This proposal is problematic in several respects. One problem is posed by the suggestion that the weak inflection overtly marks the IM/RRC source. For one thing, in all weak patterns (I-III), we find unambiguous instances of non-predicative adjectives, which, according to Cinque's own criteria, should be considered direct modifiers:

- (106) a. fransk.i forseti - nn (I)
 French.WK president - DEF
 (thematic reading: 'the president of France')
- b. hinn meint.i bankaræningi (II)
 ART alleged.WK bank-robber
- c. afstæðiskening - in svokallað.a (III)
 theory-of-relativity - DEF so-called.WK

These examples are in and of themselves counterevidence to the claim that weak adjectives qua weak inflection are indirect modifiers/RRCs. Even more devastating is the following aspect: on a strict interpretation of the RRC analysis (Kayne 1994; Alexiadou and Wilder 1998; Alexiadou 2001; Cinque 2010), indirect modifiers are literally assumed to be generated as syntactic predicates in a relative clause, which is construed as a CP complement to D:

- (107) [_{DP} D [_{CP} [_{IP} NP AP]]]

As was pointed out in section 2.2, however, the defining characteristic of the weak inflection is that it is restricted to adnominal contexts and cannot occur on adjectival predicates. This solid empirical fact confronts any analysis that proposes that weakly inflected adjectives are RRCs with the problem: How can weakly inflected adjectives occur in an alleged predication structure, when they are otherwise ungrammatical in all actual predication structures? On an analysis like (107), we would expect that *gul.i bíll-inn* 'yellow.WK car-DEF' derives from something that has [_{IP} bíll gul.i] as a constituent, although the structure **bíllinn er gul.i* 'the car is yellow.WK' is ungrammatical (cf.: *^{ok}bíllinn er gul.ur* 'the car is yellow.STR'). If the generalization regarding the distribution of weak adjectival inflection (see section 2.2.1) is taken seriously, analyses that rely on the assumption that weakly inflected adjectives are syntactic predicates of some kind are not viable. Hence I conclude that adjectives in patterns (I)-(III) cannot be RRCs; at least not in a (syntactically) literal sense.

Conversely, the idea that strongly inflected adjectives, i.e. pattern (IV) appositives, are direct modifiers is not tenable either. Among the criteria Cinque gives for

DM and IM (see table 3.1), some are not applicable in the first place. In section 3.1.1 above, I argued that pattern (IV) appositives are not non-restrictive, because they do not combine with a set-denoting expression. Precisely for that reason they are not defined for either intersectivity or non-intersectivity.

Other criteria clearly point the other direction, meaning that, in some respects, pattern (IV) appositives behave like indirect modifiers according to Cinque's criteria. Most saliently, both necessarily have a predicative reading and allow only a literal interpretation. Direct modifiers, on the other hand, may be non-predicative and can have an idiomatic reading. Also recall that textbook direct modifiers like 'alleged' and other non-predicative adjectives like 'so-called' are not possible in pattern (IV), cf. example (83) and (106) above.

In short, pattern (IV) appositives most certainly are not direct modifiers. If anything, the evidence suggests that they have a predicative "source" similar to indirect modifiers. One crucial factor that actually supports this last conclusion is the adjectival inflection. Above I rejected a RRC analysis for patterns (I)-(III) on grounds of the adjective involved being inflected weakly. An adjective assumed to be generated as a syntactic predicate cannot be weakly inflected; it must be strongly inflected. But the distinguishing morphological feature of pattern (IV) is precisely that the adjective involved is strongly inflected. Furthermore, recall that pattern (IV) appositives can always be paraphrased by a (relative, adverbial, or conjunct) clause, which indirectly suggests that they themselves are clause-like. Thus their predicativity and their presumed clausehood make pattern (IV) appositives the most likely candidates for which a RRC analysis is viable.

Nonetheless, in spite of some obvious similarities, pattern (IV) appositives cannot be indirect modifiers in Cinque's sense. On Cinque's account, all semantic values "necessarily go together" (op. cit.:17), which means that indirect modifiers are predicative **and** literal **and** intersective ... **and** restrictive etc.. But with respect to the property (*non-*) *restrictivity*, as Cinque himself points out (see above), we find a serious mismatch: pattern (IV) appositives most certainly are not restrictive, whereas Cinque's indirect modifiers are supposed to be "necessarily" restrictive. Below I give a brief comparison of pattern (IV) appositives and indirect modifiers in Cinque's sense:

(IV)-appositives	INDIRECT MODIFICATION/RRC
<i>only predicative</i>	<i>only predicative</i>
<i>only literal</i>	<i>only literal interpretation</i>
appositive	restrictive
(not applicable)	intersective
??? (see section 3.1.2)	stage (or individual) level

Table 3.2: Pattern (IV) appositives vs. indirect modifiers

This suggests that pattern (IV) appositives are neither direct nor indirect modifiers, but seem to instantiate yet another “source”, as if there are two kinds of indirect modifiers. Recall from section 3.1.1 that Sproat and Shih indirectly hint at that possibility by demonstrating that Chinese indirect modifiers may “occur either inside or outside” DP. I argued that the “outside” scenario essentially describes the distinctive structural feature of pattern (IV) modifiers (which are merged above *articleP*). Cinque, on the other hand, gives an account of indirect (and direct) modifiers that are all located between D and NP, which suggests that he generalizes the “inside” scenario to all indirect modifiers.

In spite of the obvious similarity to Sproat and Shih’s “outside” indirect modifiers in Chinese, I will not adopt the label *indirect modifier* in order to avoid confusion with the Cinquean conception. Nonetheless the question still remains: should pattern (IV) appositives be construed as clausal constituents - RRC or other? One possibility already sketched above is the following:

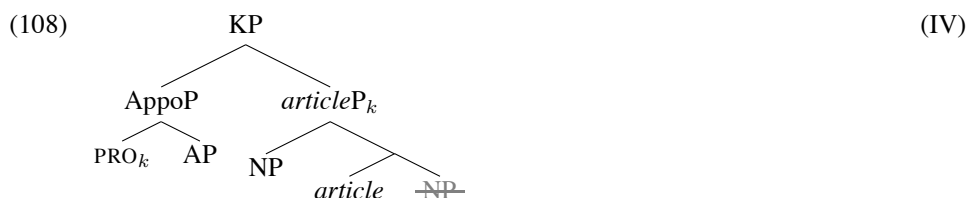

Here the appositive modifier is construed as some kind of small clause that contains an unpronounced pronominal element in subject position which is coindexed with *articleP*; *articleP*, in turn, denotes the noun phrase referent. For an example like (91a) (= *full.ur strákur - inn* ‘drunk.STR boy - DEF’), this structure would potentially give us the expected interpretation:

- (109) $\llbracket \text{fullur strákurinn} \rrbracket = k \ \& \ \text{drunk}(k)$, where $k =$ ‘the boy’
- referent: ‘the boy’
 - comment: the boy is drunk

However, this structure presents a range of problems for compositionality. On the one hand, the referential part of the noun phrase, i.e. the *articleP* (\sim DP), must denote an individual of type $\langle e \rangle$, given our assumptions. But the same goes for the extended nominal projection as a whole, i.e. KP. On the other hand, if AppoP is indeed a clause comprising a predicate and a subject argument (albeit unpronounced), it is expected to be of type $\langle t \rangle$. Neither *articleP* nor AppoP is thus a functor that could take the other as an argument, leave alone yield an entity of type $\langle e \rangle$. To obtain the required result, AppoP, or some extension of it, would have to be of type $\langle e, e \rangle$.

Alternatively, instead of analysing pattern (IV) appositives themselves as clausal elements, we can construe them as simple predicates over individuals (of type $\langle e, t \rangle$). The obvious technical obstacle is that KP is predicted to be of type $\langle t \rangle$. This is an absolutely undesired result since KP is a nominal constituent, not a clausal constituent. What we want is for functional application to simultaneously apply (yielding a “comment” proposition) and not apply (leaving the denotation of the referent unaltered):

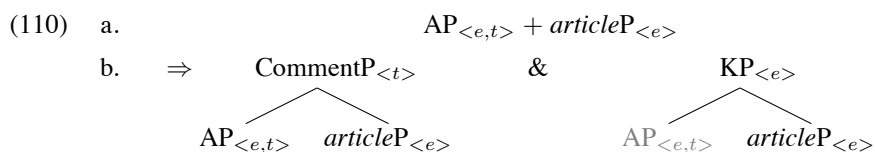

In the next section, I will introduce an analysis that accomplishes exactly that.

3.2 Potts' Logic of Conventional Implicatures

The notion of *Conventional Implicature* (CI) was introduced by Grice (1975), but has ever since mostly existed in *Introduction-to-Pragmatics* textbooks assumed to be relevant for a rather small number of lexical items ('but', 'even'). Potts (2003, 2005, 2007b) takes “a fresh look at an old definition”, and shows that CIs instantiate an ubiquitous aspect of natural language. In particular, he shows that, given a precise formalization, CIs can be used to account for various phenomena that had not hitherto be thought to be amenable to a unified analysis. Appositive modification is one of those, and, obviously, the most relevant one in the present context.

In the following, I will give the gist of Potts' formal system and his analysis of appositives, and show how this analysis can be adapted to pattern (IV) appositives. Finally, I will address a phenomenon that is captured by Potts' analysis and corroborated by Icelandic data: expressive modifiers.

3.2.1 'Not at-issue' meaning

According to Potts, the most central features of CIs are the following:

- (111) a. CIs are part of the conventional (lexical) meaning of words.
 b. CIs are commitments, and thus give rise to entailments.
 c. These commitments are made by *the speaker of the utterance* "by virtue of the meaning of" the words he chooses.
 d. CIs are logically and compositionally independent of what is "said (in the favored sense)", i.e., independent of the at-issue entailments.

(Potts 2005:11)

In particular, CIs are

- (112) a. invariably speaker-oriented
 b. invariant under holes, plugs

(Potts 2005:26)

Potts crucially distinguishes two dimensions of meaning: what is asserted (*at-issue-content*) and what is conventionally implicated (*not-at-issue-content*). The former is the semantic content of an expression in the traditional (truth-conditional) sense. The latter is the semantic contribution of an expression which is processed in parallel to the at-issue content, on a separate plane as it were, but does not interact with it. This distinction is formally implemented in the semantic type of the respective expressions (indicated by the superscripts ^a and ^c) and the rules for functional application:

- (113) a. e^a , t^a and s^a are basic at-issue types
 b. e^c , t^c , and s^c are basic CI types
 c. if σ and τ are at-issue types, then $\langle \sigma, \tau \rangle$ is an at-issue type
 d. if σ is an at-issue type and τ is a CI type, then $\langle \sigma, \tau \rangle$ is a CI type

Note that the argument expression must always be an at-issue type; so we have only two licit instances of functional application:

- (114) a. $\langle \sigma^a, \tau^a \rangle$: FA from at-issue to at-issue
 b. $\langle \sigma^a, \tau^c \rangle$: FA from at-issue to CI
 c. $\langle \sigma^c, \tau^a \rangle$: (not defined)
 d. $\langle \sigma^c, \tau^c \rangle$: (not defined)

Let us have a look at an abstract example: assume that some expression α has the at-issue type $\langle \sigma^a \rangle$, and its sister β has the CI type $\langle \sigma^a, \tau^c \rangle$. The outcome of functional application then will receive a representation as in (115):

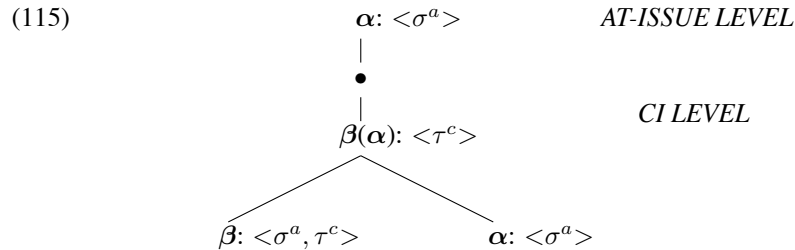

As we can see, the “mother node” is actually a two-layered construct, separated by a bullet • point, comprising the two dimensions of meaning (at-issue and CI), which is a consequence of CI-functional application. On the one hand, expression α is passed up to the top node unaltered as if functional application had not happened. The output $\alpha: \langle \sigma^a \rangle$ (just as the input $\alpha: \langle \sigma^a \rangle$) contributes at-issue content and is visible by the semantic component. That is, it may be input to further computation (like functional application). On the other hand and simultaneously, functional application does happen, such that the output $\beta(\alpha): \langle \tau^c \rangle$ contributes CI content which is “logically and compositionally independent” of the at-issue content, and which is not visible by the semantic component in the sense that it cannot further enter any compositional operations.

3.2.2 Appositives

Potts dedicates a large portion of the discussion to (parenthetical) nominal appositives as in (116) (*italics mine*) as prototypical instances of CIs:

- (116) a. Lance, *a cyclist*, is from Texas (Potts 2007b:489)

Focusing on the complex noun phrase and the sentence as a whole, (116) makes the following distinct semantic contributions:

- (117) a. **at-issue content** (referent): *Lance*
 b. **CI content** (comment): *Lance is a cyclist*
 c. **at-issue content** (assertion): *Lance is from Texas*

Given the technical assumption from the previous subsection, the noun phrase ‘Lance, a cyclist’ is straightforwardly analysed as follows:

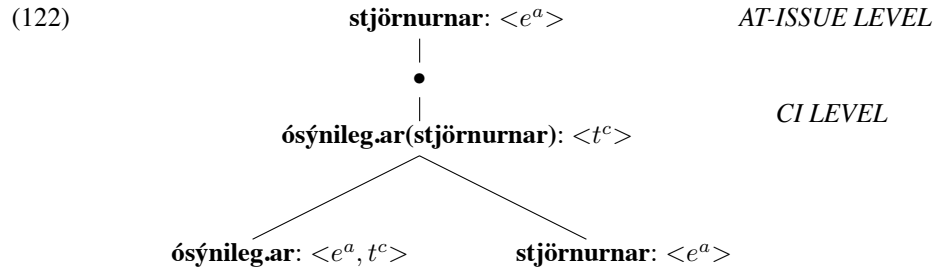

But beyond the mere technical aspects of compositionality, an analysis along these lines also captures the semantic properties of pattern (IV) appositives straightforwardly. In fact, it captures aspects that a simple clausal analysis (RRC or other) would fail to satisfactorily explain. Appositivity itself (i.e. the absence of restrictivity) results from the appositive’s not being compositionally integrated into the referential expression, rather taking the referential expression (denoting a fully established referent) as an argument. This is basically just another way of stating that the appositive is merged outside the definite noun phrase, that is, outside *articleP*, which I have established on independent grounds for pattern (IV) elements. A clausal analysis of pattern (IV) appositives could presumably capture this property as well merely on structural grounds. However, a clausal analysis would not be able to account for pattern (IV) appositives’ not being bound by attitude operators, see the discussion in section 3.1.2. On the other hand, this is exactly what the CI analysis predicts insofar as CIs are “commitments made by the speaker of the utterance” and “invariably speaker-oriented”; moreover, they are “logically and compositionally independent” of the at-issue content of an expression.

In addition, there is another kind of modifiers that, on Pott’s analysis, contribute CI content: expressives. Those are certainly not susceptible to a clausal analysis – but they are pattern (IV) modifiers.

3.2.3 Expressives

Expressives comprise, amongst others, modifiers like “bloody”, “damn”, “fucking” etc.. They do not denote properties at all, but rather express the speaker’s attitude towards a referent:

(123) The bloody car is broken again!!

Thus they constitute another prototypical group of elements that convey CI content, and they play a significant role in Potts’ argumentation.

In other words, appositives and expressives have in common that both contribute CI content. What is most interesting (and relevant) in the present context is

that, in Icelandic, both occur as pattern (IV) constellations:⁷

(124) *Pattern (IV) expressives*

- a. **Bölváð.ur bíll - inn** situr fastur!
 cursed.STR car - DEF sits tight
 'The bloody car got stuck!'
- b. Ég fann ekki **blessað.an lykil - inn**!
 I found not blessed.STR key - DEF
 'I didn't find the damn key!'

The noun phrase *bölváður bíllinn* in (124a) can be seen as conveying two pieces of semantic information:

- (125) a. **at-issue content** (referent): *the car*
 b. **CI content** (comment): *"I hate the car"*
 (~ speaker disapproves of the car)

Glossing over a number of technical details in Potts' analysis of expressives for the sake of simplicity, we can analyse this example as follows:⁸

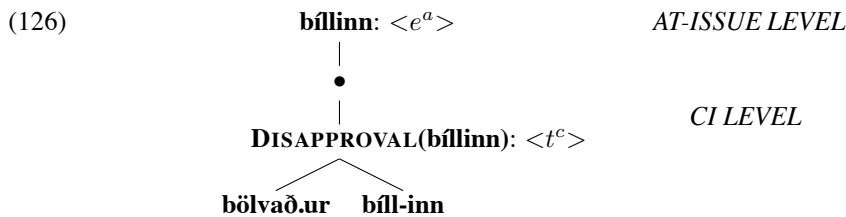

Given the fact that expressives occur as pattern (IV) modifiers, my analysis of strong adjectival inflection in section 2.2 would independently require that they occur outside *articleP*. In this connection, it is worth mentioning that (Potts 2007a:267) states: "But my theory still predicts that **damn the dog* should surface instead of *the damn dog*" because, on my account, this is precisely the (underlying) order of its Icelandic counterpart: [**bölváður** [*articleP* hundur **-inn hundur**]].⁹

He further states: "I also have no account of [the] observation that expressives tend to sit at the outer edge of the modifier domain, and that they in turn take on

⁷Note that nouns are also often used in the expressive function, typically in the genitive case: *andskotans*, *djöfulsins* 'the devil's', *helvítis* 'hell's' etc..

⁸Potts uses "a function called **bad**" (Potts 2003:225) as a metapredicate for expressives, and adds: "[i]t might [...] be better to regard **bad** as the name of the function that says, roughly, 'the speaker is in a heightened emotional state regarding X'" (op.cit.:226). Moreover, he assumes a more complicated semantics for expressives owing to the fact they can take arguments of different types that I will not consider here.

⁹On the other hand, of course, I do not have an explanation for the English order as things stand.

literal meanings if they are placed closer to the noun than unambiguously descriptive modifiers” (ibid.). Here I would like to add the observation that expressive meaning is *only* available in pattern (IV), not in the weak patterns (I)-(III), where the adjective can only have a literal meaning:

- (127) ‘the blessed ring’
- | | |
|---|--------------|
| a. blessað.i hringur - inn | (I) |
| b. hinn blessað.i hringur | (II) |
| c. hringur - inn blessað.i | (III) |
| blessed by a priest or by god (for instance a wedding ring) | → literal |
| d. blessað.ur hringur - inn | (IV) |
| ‘the damn ring! (I can’t get it off my finger)’ | → expressive |

The difference between patterns (I)-(III), on the one hand, and pattern (IV), on the other hand, on my account, is that the adjective in the former is merged *articleP*-internally, whereas pattern (IV) modifiers are merged *articleP*-externally. To the extent that this analysis is on the right track, we can conclude that *articleP* marks a boundary only outside of which expressive modification is possible (at least regarding the cases at hand).

3.3 More Evidence

In section 2.2, I proposed that the strongly inflected element in pattern (IV) noun phrases is merged outside the definite noun phrase, which has so far meant outside *articleP*. The strong inflection itself has been regarded a morphological reflex of this underlying constellation. On the other hand, being merged outside *articleP*, the semantic expectation is for pattern (IV) to combine with a referential expression of type <e>. The discussion of appositive and expressive modifiers has shown that this expectation is indeed borne out.

But the preceding discussion has not exhausted the use of pattern (IV); there are two more uses that I will briefly mention here.

3.3.1 Positional Predicates

For one thing, there is a small group of adjectives that we might call *Positional Predicates*; these denote temporal and spatial relations, and in a sense, they behave more like prepositional phrases. Like ordinary adjectives, however, they agree with the noun in case, number and gender, and what is more, they are exclusively used

in the strong inflection. Also, they typically combine with a noun + suffixed article (N-DEF). Thus they formally fit the profile of pattern (IV):¹⁰

- (128) a. á norðanverð.u nesi - nu
on northern.STR peninsula - DEF
'on the northern part of the peninsula'
- b. í mið.ri borg - inni
in middle.STR city - DEF
'in the middle part of the city / in the city center; downtown'
- c. um þver.an heim - inn
about transverse.STR world - DEF
'around the world'
- d. öndverð.ur vetur - inn
beginning.STR winter - DEF
'the winter in its early part (the beginning of the winter)'

As has been the case with all pattern (IV) elements so far, positional predicates do not modify the reference of the noun phrase, but rather operate on an already established and identifiable referent. So far, that referent has been the denotation of an *articleP* consisting of (common) noun + suffixed article (N-DEF). What is interesting about positional predicates is that they can furthermore combine with inherently referential expressions like proper names and even pronouns:

- (129) a. á sunnanverð.ri Ítalíu
on southern.STR Italy
'in the southern part of Italy'
- b. í mið.ri Reykjavík
in middle.STR Reykjavík
'in downtown Reykjavík'
- c. ... á og brú í mið.ri henni
... river and bridge in middle.STR her (NB: á 'river' is feminine)
'... a river and a bridge in the middle of it'

Moreover, note that, if the DP is headed by definite determiners that surface in prenominal position, like demonstratives and ART, the positional predicate precedes the determiner:

- (130) a. á ofanverð.um þessum vetri
on ending.STR this winter
'in the latter part of this winter'

¹⁰Many of them involve the the component *-verður*, for instance: *austan-/vestan-/norðan-/sunnanverður* '(in) the eastern/western/northern/southern part (of)'; *utanverður* 'external, (on) the outside (of)'; *framanverður* '(in) the anterior/front part (of)'; *öndverður* 'early/(in) the beginning (of)'; *innanverður* 'internal, (on) the inside/the interior part (of)'; *aftanverður* '(on) the posterior/back part (of)'.

- b. frá *miðj.um* þessum mánuði
 from middle.STR this month
 ‘from the middle of this month (on)’
- c. í *mið.ri* hinni alþjóðleg.u fjármálakreppu
 in middle.STR ART international.WK financial.crisis
 ‘halfway through the international financial crisis’
- d. í *mið.ri* þeirri umræðu sem fram fór 15. mars
 in middle.STR that debate which went on 15. March
 ‘in the middle of the debate that took place on March 15’
- e. Bókin gerist mestöll á ofanverð.um sjött.a áratug - num og
 book.the happens most on ending.STR sixth.WK decade - DEF and
 öndverð.um þeim sjöund.a
 beginning.STR that seventh.WK
 ‘Most of (the events described in) the book take place in the latter part of the
 fifties and the beginning of the sixties’

Thus, positional predicates provide visible evidence for the claim that strongly inflected elements occurring ‘in’ definite noun phrases really are outside the DP in a proper sense.

3.3.2 Little Partitives

A further construction that illustrates the point to be made here extraordinarily well is instantiated by what I will call “*little*” *partitives*. Those will be contrasted with “*big*” *partitives*. The distinctive formal feature between the two is agreement/concord (or the lack thereof), as will be illustrated in more detail below.

First of all, note that the little partitive can be instantiated by pattern (IV) noun phrases which are formally identical to all other instances of pattern (IV) discussed so far, except for the fact the place of the adjective is taken by certain quantificational elements, and the noun phrase receives something that can be – and has been – described as a partitive reading:¹¹

- (131) a. marg.ar bækur - nar
 many.STR books - DEF
 ‘many of the books’
- b. sum.ar bækur - nar
 some.STR books - DEF
 ‘some of the books’

An observation going back to Jackendoff (1977) and Selkirk (1977) is that (proper) partitive quantifiers must combine with a definite noun phrase.¹² To the

¹¹See also Sigurðsson (1993, 2006) and (Delsing 1993:187-91).

¹²Beyond merely “formally definite”, partitive noun phrases have been described as *strong* (Mil-sark 1974), *necessarily specific* (Enç 1991) or *presuppositional* (Musan 1999). The guiding intuition behind this is that “a partitive refers to a discourse-given set” (von Heusinger 2002:262).

extent that examples like (131) really are partitives, this (formal) definiteness criterion is obviously fulfilled by the presence of DEF in pattern (IV) noun phrases. In addition, with little partitives, definiteness can also be marked by another definite determiner, and, as we have already seen with positional predicates, the strongly inflected element, in this case the quantifier, precedes the determiner:¹³

- (132) a. *ýms.ar þessar bækur*
various.STR these books
'several of these books'
- b. *sum.ar þær bækur sem ...*
some.STR those books that ...
'some of those books that ...'
- c. *flest.ar mínar hugmyndir*
most.STR my ideas
'most of my ideas'
- d. *marg.ir hinir vitrustu menn*
many.STR ART wisest men
'many of the wisest men'

Both the examples in (132) and the pattern (IV) constructions in (131) illustrate the characteristic formal property of what I call little partitives: agreement/concord. The quantifier fully agrees with determiner and noun in ϕ -features, but also – and especially – in case:¹⁴

- (133) “little” partitives:
- a. i. *marg.ar bækur - nar*
[many.STR books - DEF]-FEM.PL.NOM/ACC
- ii. *mörg.um bóku - num*
[many.STR books - DEF]-FEM.PL.DAT
- iii. *marg.ra bóka - nna*
[many.STR books - DEF]-FEM.PL.GEN
- b. i. *marg.ar þessar bækur*
[many.STR these books]-FEM.PL.NOM/ACC
- ii. *mörg.um þessum bókum*
[many.STR these books]-FEM.PL.DAT
- iii. *marg.ra þessara bóka*
[many.STR these books]-FEM.PL.GEN
'many of the(se) books'

At any rate, (131) and (132) provide further corroboration for the claim that strongly inflected elements ‘in’ definite noun phrases are actually outside the DP (i.e. that strongly inflected modifiers are really merged above definiteness morphemes). But little partitives have more to offer. A small number of the quantifiers that can occur in little partitive constructions can also occur DP-internally (viz.

¹³See also (Sigurðsson 1993:182/3) and (Sigurðsson 2006:207) for examples of this kind.

¹⁴For that reason, constructions like these have been called “agreement constructions” (Sigurðsson 1993), or “Full Concord Constructions” (Sigurðsson 2006).

weak or cardinal quantifiers), and, when merged inside the DP, they receive a cardinal reading:

- (134) a. marg.ar **þessar** bækur
 many.STR these books
 ‘many of these books’ PARTITIVE
- b. **þessar** mörg.u bækur
 these many.WK books
 ‘these many books’ CARDINAL

This contrast illustrates the syntactic, morphological and semantic components of the present proposal very effectively. In (134a), the quantifier

- (i) **precedes the definite determiner**, which I take to be visible evidence for its being outside DP,
- (ii) is **strongly inflected**, which is expected on the account proposed here because of the quantifier being outside the c-command domain of the [DEFINITE] feature, and
- (iii) we obtain a **partitive reading**, which is compatible with the quantifier combining with a definite noun phrase, which is, in turn, a given on the present proposal.

In (134b), on the other hand, the quantifier

- (i) **follows the definite determiner**, which I take to be visible evidence for its being inside DP,
- (ii) is **weakly inflected**, which is expected on the account proposed here because the quantifier is in the c-command domain of the [DEFINITE] feature, and
- (iii) we obtain a **cardinal reading**, which is compatible with the quantifier combining with a set-denoting expression of type $\langle e,t \rangle$ (\sim NP).¹⁵

As already mentioned, little partitives contrast with big partitives of which there are two instances: the quantifier combines with either with a genitival DP or with a PP (headed by the dative-assigning preposition *af* ‘of’). In both cases, the quantifier itself may be assigned any case (by a verb, preposition or T⁰),¹⁶ while the rest of the noun phrase invariably has a dependent case (genitive or dative):

¹⁵NB: cardinality is a property of sets.

¹⁶In other words, the case on the quantifier reflects the position/function of the noun phrase as a whole within the sentence.

(135) “big” partitives A: (Q + genitival DP)

- a. i. marg.ar bóka - nna
many.FEM.PL.NOM/ACC [books - DEF]-FEM.PL.GEN
- ii. mörg.um bóka - nna
many.FEM.PL.DAT [books - DEF]-FEM.PL.GEN
- iii. marg.ra bóka - nna
many.FEM.PL.GEN [books - DEF]-FEM.PL.GEN
- b. i. marg.ar þessara bóka
many.FEM.PL.NOM/ACC [these books]-FEM.PL.GEN
- ii. mörg.um þessara bóka
many.FEM.PL.DAT [these books]-FEM.PL.GEN
- iii. marg.ra þessara bóka
many.FEM.PL.GEN [these books]-FEM.PL.GEN

‘many of the(se) books’

(136) “big” partitives B: (Q + PP)

- a. i. marg.ar af bóku - num
many.FEM.PL.NOM/ACC of [books - DEF]-FEM.PL.DAT
- ii. mörg.um af bóku - num
many.FEM.PL.DAT of [books - DEF]-FEM.PL.DAT
- iii. marg.ra af bóku - num
many.FEM.PL.GEN of [books - DEF]-FEM.PL.DAT
- b. i. marg.ar af þessum bókum
many.FEM.PL.NOM/ACC of [these books]-FEM.PL.DAT
- ii. mörg.um af þessum bókum
many.FEM.PL.DAT of [these books]-FEM.PL.DAT
- iii. marg.ra af þessum bókum
many.FEM.PL.GEN of [these books]-FEM.PL.DAT

‘many of the(se) books’

It has been pointed out in the literature (for instance Delsing 1993:187, fn.2; Sigurðsson 1993:184, 2006:207) that partitivity is normally expressed by big partitives, whereas little partitives, i.e. agreement/concord constructions, are a (stylistically) marked option. In addition, there are semantic differences and felicity conditions that are not easily described, but it seems to be possible to single out one subtle aspect. Consider the following example (inspired by Núria 2003:46):

- (137) a. margir krakkar - nir, sem voru að leika sér, fóru að rífast
many children - DEF who were playing started fighting
many_j of [the children]_k who_{k/*j} were playing ...

- b. margir krakka - nna, sem voru að leika sér, fóru að rífast
 many [children - DEF]-GEN who were playing started fighting
 many_j of [the children]_k who_{k/j} were playing ...
- c. margir af krökku - num, sem voru að leika sér, fóru að rífast
 many of [children - DEF]-DAT who were playing started fighting
 many_j of [the children]_k who_{k/j} were playing ...

Judgments are a bit delicate, but what we can say is this: big partitives as in (137b/c) can, at least in principle, establish two possible antecedents for anaphoric elements, whereas little partitives as in (137a) can only establish one antecedent. So the relative pronoun in (137b/c) can, in principle, make reference to the totality of salient children in the given context or to the subset of children, delimited by the partitive quantifier ‘many’. In (137a), it can only refer to the subset of children.¹⁷

In other words, little partitives denote exactly one referent. This semantic aspect has a syntactic correlate: the quantifier and the rest of the noun phrase are in the same *case domain* in that they agree in case, cf. (133). This is easily accounted for on the assumption that I have tacitly applied to pattern (IV) constructions all along, viz. that both are constituents of the same KP:

(138) little partitive: [_{KP} QP DP]

Conversely, the only coherent conclusion for big partitives then is that they comprise two case domains;

(139) big partitive: [_{KP₂} [_{QP} Q [_{KP₁} DP]]]

I will have nothing further to say about big partitives here. For little partitives, we can assume an abstract structure like (140); I include the position for DP-internal weak quantifiers with the cardinal reading, cf. (134), in order to indicate their position relative to the definiteness morpheme:

¹⁷The same seems to go for pronominal reference in cases like: *many_j of [the children]_k ... they...*

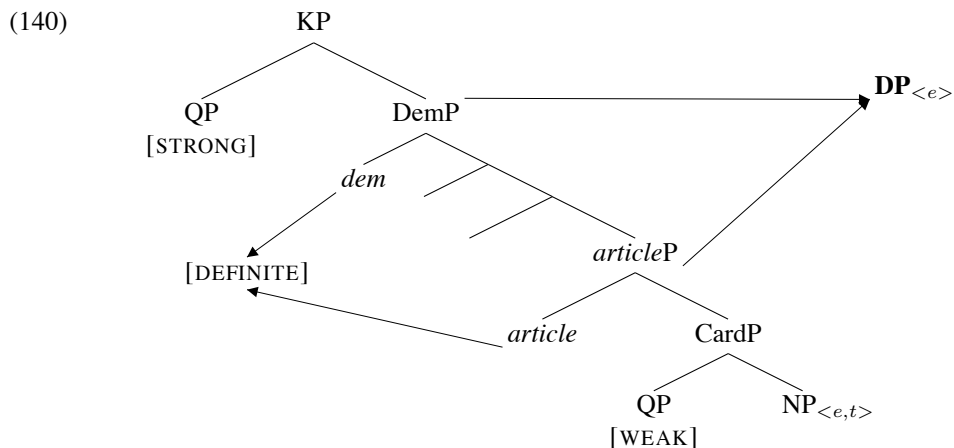

Before concluding this subsection, I will briefly comment on the status of numerals as little partitives. For distributional and semantic reasons, numerals are usually classified along with elements such as ‘many’, ‘few’ etc. as cardinal or weak quantifiers. In Icelandic, these elements differ morphologically in that, amongst the inflecting numerals (1-4), only the number ‘one’ displays the strong-weak distinction, cf. fn. 20, whereas ‘two’ to ‘four’ have only one inflection.¹⁸

In section 2.1.2, it was mentioned that numerals are fine in patterns (II) and (III), where the latter is the unmarked case, but they cannot occur in pattern (I):

- (141) a. *sjö höfuðsýndir - nar (I) c. höfuðsýndir - nar sjö (III)
 seven cardinal-sins - DEF cardinal-sins - DEF seven
 b. hinar sjö höfuðsýndir (II)
 ART seven cardinal-sins

The problem with this latter characterization is that, since numerals do not distinguish between strong and weak inflection, it is impossible to morphologically distinguish between a pattern (I) and a pattern (IV) configuration. However, the constellation NUM - N-DEF is, in principle, possible, albeit somewhat marginal, but it can only have a partitive, not a cardinal reading:¹⁹

¹⁸Numbers above four are not inflected at all, except for compound numbers containing an inflecting numeral (24, 33, 42, 51 etc.).

¹⁹The partitive reading of numerals in examples like (142) has been noted by Sigurðsson (2006); Pfaff (2007, 2009); both note that the felicity of numerals in little partitives seems to be largely contingent on the presence of a superlative modifiers:

- (1) a. Fjórar frægustu kenningar - nar eru rangar
 four famous.SUPERL theories - DEF are wrong
 ‘four of the most famous theories are wrong’ (Sigurðsson 2006:207)

- (142) ?fjórar kenningar - nar
 four theories - DEF
 ‘four of the theories’
 #‘the four theories’

Given the previous discussion of this section, I take this to mean that numerals can, in fact, participate in a little partitive construction, and more generally, that they can, in principle, occur as pattern (IV) modifiers. The non-availability of the cardinal reading, I take to support the claim that numerals really cannot occur in pattern (I).

3.4 Summary

In section 2.2, I set forth the claim that a modifier occurs strongly inflected if the weak inflection is not triggered. Weak inflection itself is triggered if the modifier occurs in the c-command domain of the feature [DEFINITE]. The consequence for pattern (IV) is that the (strongly inflected) modifier involved must be assumed to be merged higher than the definiteness morpheme, that means outside *articleP* (DP). The claim was primarily made from a purely morpho-syntactic perspective.

This chapter has looked at pattern (IV) modifiers from various angles and shown that there is indeed overwhelming support for that claim. From a semantic point of view, the most important corollary of the proposal is that the pattern (IV) modifier is predicted to combine with a referential expression of type <e>. This has been shown to be the case for all manifestations of pattern (IV). As was shown, for instance, many semantic properties of pattern (IV) appositives cannot be properly understood unless we assume that they are not a constituent of (a certain part of) the definite noun phrase – which goes hand in hand with the independently established assumption that pattern (IV) modifiers are merged outside *articleP* (DP).

Positional predicates and little partitive were shown to provide visible evidence for their occurring outside DP. On the other hand, I also showed that being merged outside *articleP* (DP) does not mean that pattern (IV) modifiers are not part of the same extended nominal projection. I argued, on the contrary, that they belong to the same case domain as the rest of the noun phrase, i.e. pattern (IV) modifiers and *articleP* (DP) are constituents of the same KP.

b. Hann svaraði þremur síðustu spurningu - num
 he answered three last questions - DEF
 ‘he answered three of the last questions’

(Pfaff 2007:59)

I will not attempt to address these subtle details here.

It was also shown that pattern (IV) appositives come closest to Cinque's conception of indirect modifiers in that they appear to be genuine predicatives. However, they completely fail a number of Cinque's semantic criteria (not restrictive!), which suggests that they are not indirect modifiers in Cinque's sense after all. Likewise if any class of adjectives is to be analysed as RRCs, it is pattern (IV) appositives, rather than weakly inflected adjectives. Nonetheless this is no necessary conclusion since there is an alternative construal as CIs. For this purpose, I have argued that Pott's semantics of non-at-issue types can be applied to pattern (IV) appositives (and for that matter, to pattern (IV) expressives).

It may turn out that some specifics need to be revised or modified; for instance, nominal appositives as discussed by Potts and other constructions usually considered appositive are prosodically not integrated, whereas pattern (IV) modifiers are prosodically integrated. I leave a closer comparison of pattern (IV) appositives and other appositive constructions to further research. What I have shown here, however, is that pattern (IV) modifiers have the unifying feature that they modify entities denoted by *article*P (DP), rather than entities denoted by smaller nominal projections.

Chapter 4

The Weak Patterns

In this chapter, I will have a closer look at the weak patterns (I), (II) and (III). I will provide further evidence for OAA, but also try to characterize a number of structural and semantic properties of the individual patterns. The discussion will be far from exhaustive, and I will focus exclusively on a number of selected aspects.

Recall from section 2.1.2 that pattern (I) is by far the most common means of adjectival modification for definite noun phrases and covers a wide range of uses. Instead of looking at every possible use, I will establish some central properties of pattern (I), and in particular, show which functions can only be executed by pattern (I), and in which cases pattern (I) is systematically unavailable – as opposed to patterns (II) and/or (III). As for pattern (II), recall that it is often associated with a certain “literary flavour”. This aspect will be completely ignored; for the most part, I will be interested in which interpretations the adjective involved can, at least in principle, have, and which readings are categorically not available. The same goes for pattern (III).

A joint perspective on syntactic and semantic factors will point towards the conclusion that we have to distinguish at least three zones in which (weak) adjectives can be merged, which has an impact on their possible semantic interpretations. Adjectives merged in the lowest zone only surface in pattern (I); adjectives merged in the middle zone can surface in pattern (I) or (II); and adjectives merged in the highest zone surface either in pattern (II) or (III). Only adjectives in that zone can be stranded.

NB: Since this chapter is dedicated to the “weak” patterns, weak inflection will not be marked in the glosses.

4.1 Properties of the Weak Patterns

4.1.1 "Mixed" Patterns (I)+(III)

First of all, I would like to draw attention to an observation not mentioned so far. The examples used to illustrate the validity of OAA according to Pfaff (2007, 2009) in section 2.1.5 involved one adjective, which either remains in situ, or moves along with the nominal constituent (here simply labeled ‘NP’):

- (143) a. [ARTICLE [AP NP]] → [[AP NP]-ARTICLE [~~AP NP~~]] (I)
 b. [ARTICLE [AP NP]] → [ARTICLE [AP NP]] (II)
 c. [ARTICLE [AP NP]] → [NP-ARTICLE [AP ~~NP~~]] (III)

With two adjectives, on the other hand, we find an interesting twist. Both adjectives can occur prenominally, which can then be simply seen as an extended version of patterns (I) and (II), respectively, with nothing interesting to say about (yet). The adjectives normally show up in the ordering expected on independent grounds (AORs, see section 1.1.3). In addition, we find pattern (I)+(III) “hybrids” where one adjective occurs prenominally, and the other one postnominally (i.e. post-articularly). Such a constellation will be referred to as “mixed pattern”. Under the OAA as developed so far, pattern (I) is derived by moving a constituent containing the sequence [AP NP] from the post-articular to a pre-articular position, and pattern (III) is derived by moving a constituent containing the NP to a pre-articular position while stranding the adjective in postnominal position. For mixed patterns of the kind just mentioned, the prediction is that it is the lower adjective that moves along, yielding the pattern (I) component, while the higher one gets stranded postnominally, yielding the pattern (III) component:

- (144) a. [ARTICLE [AP₁ AP₂ NP]] → [[AP₁ AP₂ NP]-ARTICLE t] (I)
 b. [ARTICLE [AP₁ AP₂ NP]] → [ARTICLE [AP₁ AP₂ NP]] (II)
 c. [ARTICLE [AP₁ AP₂ NP]] → [[AP₂ NP]-ARTICLE [AP₁ t]] (I)+(III)

In other words, the postnominal adjective is expected to be merged higher than and thus have scope over the prenominal one, cf. (144c). As the following examples illustrate, this prediction is borne out:¹

¹Except for (145e/g/n), all examples are taken from MIM. The ordering given below each example indicates the unmarked ordering, or the respective scope relations.

- (145)
- | | |
|--|--|
| <p>a. kalda stríð - ið svokallaða
cold war - DEF so-called
SO-CALLED >> COLD</p> <p>b. rauði dregill - inn margnefndi
red carped - DEF often-mentioned
OFTEN-MENTIONED >> RED</p> <p>c. litli maður - inn nýskírði
little man - DEF new-baptized
NEW-BAPTIZED >> LITTLE</p> <p>d. frjálslynda guðfræði - n svonefnda
liberal theology - DEF so-called
SO-CALLED >> LIBERAL</p> <p>e. guli bíll - inn frægi
yellow car - DEF famous
FAMOUS >> YELLOW</p> <p>f. franskur heimspekingur - inn snjalli
French philosopher - DEF brilliant
BRILLIANT >> FRENCH</p> <p>g. gamla kona - n blinda
old woman - DEF blind
BLIND > OLD</p> | <p>h. rauða hús - ið góða
red house - DEF good
GOOD >> RED</p> <p>i. malasíska leikkona - n fagra
Malaysian actress - DEF beautiful
BEAUTIFUL >> MALAYSIAN</p> <p>j. bandaríska söngkona - n rauðbirkna
American singer - DEF red-hued
RED-HUED >> AMERICAN</p> <p>k. kínverska máltæk - ið góða
Chinese proverb - DEF good
GOOD >> CHINESE</p> <p>l. rússneski línumaður - inn öflugur
Russian line-player - DEF strong
STRONG >> RUSSIAN</p> <p>m. þýska mannæta - n ógæðfellda
German cannibal - DEF unpleasant
UNPLEASANT >> GERMAN</p> <p>n. blinda kona - n gamla
blind woman - DEF old
OLD > BLIND</p> |
|--|--|

In all these examples, the post-articular (postnominal) adjective scopes over the pre-articular (prenominal) one. This is a natural consequence of OAA, insofar as the former is assumed to be merged higher than the latter. In fact, this observation strongly supports the validity of OAA. Moreover, it supports the idea that it is really phrasal (AP + NP) movement that is involved in deriving the pattern (I) component, rather than head movement.

Informally, we can characterize the prenominal adjectives in (145) as contributing a defining (or objective) property that is essential in order to identify the referent, → pattern (I), and the postnominal one as contributing a property that is of secondary importance and not necessary in order to identify the referent, → pattern (III). As was already mentioned in section 2.1.3, pattern (III) prototypically involves adjectives that may be characterized as evaluative. This can also be seen in the case at hand where we find adjectives like ‘famous’, ‘brilliant’, ‘unpleasant’ etc. in postnominal position.

More generally, there is a sense in which the information provided by the postnominal pattern (III) modifier is backgrounded. Minimal pairs such as (145g) vs. (145n) support this characterization in an interesting way: while the noun phrase referent in the former example is a certain *old* woman (who is blind), in the latter, it is a *blind* woman (who is old).

Obviously, this characterization of patterns (I) and (III) is not a far cry from a distinction in terms of restrictive vs. non-restrictive modification. This terminological dichotomy was also used by Pfaff (2007, 2009). I will return to this issue in section 4.1.2, but before concluding this subsection, let us briefly re-consider Roehrs' (2006, 2009) analysis of (non-) restrictivity discussed in section 2.1.4.² Recall that his analysis rests on the assumption that restrictive modification is the result of a modifier's being interpreted in the scope of a determiner, whereas non-restrictive modification results from the modifier's not being in the scope of the determiner:

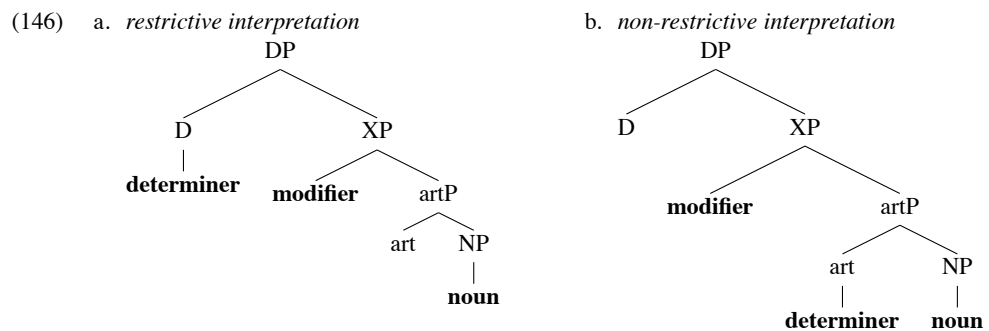

This assumption allows him to derive the restrictive reading of pattern (I) and the non-restrictive reading of pattern (II). On the other hand, the decisive detail that allowed Pfaff (2007, 2009) to argue for an OAA that pays attention to semantic facts lies in the reality of pattern (III) and the fact that adjectives can be stranded, which is not taken into account by Roehrs (2006, 2009).³

Now, since the adjective in the post-articular patterns (II) and (III) have essentially the same semantic (i.e. non-restrictive) reading, then according to (146b), the article must be interpreted in the low position in pattern (III). On the other hand, since DEF precedes the adjective in pattern (III), the article must be assumed to be spelled out in the high position. In other words, Roehr's account seems to be able to account for patterns (II) and (III) in a similar fashion – article is interpreted low and spelled out high – with the difference that the noun must also be assumed to be spelled out in a high position in pattern (III).

However, when it comes to “mixed patterns” (I) + (III), this analysis leads to a contradiction:

²Assume, for the moment, that the difference between patterns (I) and (II)/(II) really is categorically restrictive vs. non-restrictive.

³He actually addresses postnominal adjectives and adjective stranding in the context of Old Norse (see also fn. 13), and merely fails to notice that pattern (III) still exists: “As far as I am aware, it is not possible to strand adjectives in Modern Icelandic” (Roehrs 2006:17).

- (147) franskir heimspekingur - inn snjalli
 French philosopher - DEF brilliant

Given current assumptions, the adjective in the pattern (I) component (*franski heimspekingurinn*) is restrictive, and the adjective in the pattern (III) component (*heimspekingurinn snjalli*) non-restrictive. Recall that, on Roehr's account, the restrictive reading in pattern (I) is derived by interpreting the article element in the high position D^0 . On the other hand, we just saw that the non-restrictive reading in pattern (III) must be assumed to stem from the article's being interpreted in its low position art^0 . Both cannot simultaneously be the case; if the article is interpreted high, it should have scope over both adjectives, if it is interpreted low, it should not have scope over either. This is rather detrimental for Roehrs' analysis as it stands; the only modification I can conceive of to rescue it would be to assume that the adjective 'French' in (147) is actually merged below art^0 . Then, if the article is interpreted in its low position art^0 , it would have scope over 'French' (\rightarrow restrictive), but not over 'brilliant' (\rightarrow non-restrictive). But this would mean that basically all pattern (I) adjectives be re-analysed that way. On the other hand, this idea is quite similar to the proposal that I will develop in the course of this chapter.

NB: Given the general base ordering $DET \gg NUM \gg ADJ \gg N$ (cf. Cinque 2005), what has been said about mixed adjective patterns, can also be applied to numeral + adjective patterns – with an interesting twist. Recall that numerals do not surface in a pattern (I) configuration, but that they may co-occur with a following postnominal adjective. In other words, we find the following constellations:

- (148) a. [ARTICLE [NUM AP NP]] \rightarrow [[AP NP]-ARTICLE [NUM t]] (I)+(III)
 b. [ARTICLE [NUM AP NP]] \rightarrow [ARTICLE [NUM AP NP]] (II)
 c. [ARTICLE [NUM AP NP]] \rightarrow [NP-ARTICLE [NUM AP t]] (III)
- (149) a. frægu myndir - nar fjórar
 famous pictures - DEF four
 b. hinar fjórar frægu myndir
 ART four famous pictures
 c. myndir - nar fjórar frægu
 pictures - DEF four famous

Also this is a consequence of OAA, and follows naturally on the assumption that *the* article is merged in a high position, viz. above numerals.

4.1.2 (Non-) Restrictivity?

In the literature (see the reference in section 2.1.2), adjectives in pattern (I) are typically characterized as restrictive, and pattern (II) modifiers as non-restrictive. Moreover, Pfaff (2007, 2009) characterizes pattern (III) modifiers as non-restrictive as well. Mixed patterns as discussed in the previous subsection do support that characterization for patterns (I) and (III).

However, in the introductory chapter, I pointed out that the notion (*non-*) *restrictivity* is not easy to pinpoint. Recall the definitions given there:

- (150) a. an adjective A **restrictively** modifies N in c iff

$$\llbracket \mathbf{A N} \rrbracket^c \subset \llbracket \mathbf{N} \rrbracket^c \quad (\text{i.e. } \exists x: x \in \llbracket \mathbf{N} \rrbracket \ \& \ x \notin \llbracket \mathbf{A N} \rrbracket)$$
- b. an adjective A **nonrestrictively** modifies N in c iff

$$\llbracket \mathbf{A N} \rrbracket^c = \llbracket \mathbf{N} \rrbracket^c \quad (\text{i.e. } \forall x: x \in \llbracket \mathbf{N} \rrbracket \rightarrow x \in \llbracket \mathbf{A N} \rrbracket)$$

Restrictive modification targets a proper subset in the noun denotation, whereas, in non-restrictive modification, the bare noun denotation and the modified noun denotation are co-extensive. In this subsection, I will have a look at some consequences of this definition for the weak patterns.

Definition (150b) does indeed describe a central aspect of pattern (III) modifiers whose contribution may, one way or another, be described as backgrounded/evaluative:

- (151) málfræðingur - inn frægi ~ málfræðingur - inn
 linguist - DEF famous linguist - DEF

Whoever the modified noun phrase ‘the famous linguist’ refers to can be referred to by the unmodified noun phrase ‘the linguist’; so the adjective does not contribute any referentially relevant information. Something similar can be said about pattern (II) noun phrases involving evaluative adjectives:

- (152) a. hinn frægi málfræðingur b. hin ýndislega leikkona
 ART famous linguist ART charming actress

By and large, patterns (II) and (III) behave alike in this respect; the adjectives in (151) and (152) are *not* restrictive. It is less clear, however, that these cases can be analysed as involving non-restrictive modification proper, i.e. in the sense of the above definition.⁴ To see this more clearly, let us have a look at the following examples:

⁴It has been argued (for instance Umbach 2012; Martin 2014) that evaluative predicates behave differently from regular non-restrictive modification and should not be analysed in terms of simple set modification.

- (153) hinar útdauðu risaeðlur
ART extinct dinosaurs

Since all dinosaurs are extinct, the predicate ‘extinct’ is entailed, as it were, by the meaning of ‘dinosaurs’, cf. (153) (there are no non-extinct dinosaurs). In other words, extinctness is an inherent property of the referent, and the uniqueness presupposition is necessarily satisfied by the descriptive content of the noun (‘dinosaurs’) alone. We can consider cases like this non-restrictive in a strict sense. The difference to (151) and (152) is that, in those cases, the property denoted by the adjective is not a necessary property of the referent: linguists are not inherently famous.

So what we can say, so far, is that pattern (II) and (III) modifiers as in (151) and (152) are not restrictive, and that at least some pattern (II) modifiers as in (153) are non-restrictive in the strong sense of (150b).

However, there are further complications regarding pattern (II). Consider the following example:

- (154) a. hinn frægi franskur málfraeðingur
ART famous French linguist
b. hið alræmda íslenska vegakerfi
ART infamous Icelandic road-network

Even though the leftmost (evaluative) adjective is not restrictive according to what was said above, it is less clear that the same can be said about the adjective closer to the noun, which seems to make some substantial contribution to the nominal denotation.

Also recall that, in section 1.2.1, I pointed out that non-subjective adjectives are neither restrictive nor non-restrictive according to (150), and yet, those typically occur in pattern (II):

- (155) a. hinn meinti þjófur
ART alleged thief
b. hin verðandi móðir
ART becoming mother
‘the mother-to-be’

On the other hand, on a definition as the one given by Leffel (2012) (an adjective is restrictive iff it is not non-restrictive), those modifiers should be considered restrictive.

Finally, we have to consider examples like the following:

- (156) a. hinn fullkomni glæpur
ART perfect crime
b. hin hefðbundna fjölskylda
ART traditional family

Pattern (II) noun phrases often denote abstract or generic concepts. Obviously, the adjective in examples like these does make a substantial contribution to the descriptive content of the concept, and it is clearly not non-restrictive in the sense of (150b): $\llbracket \text{perfect crime} \rrbracket^c \neq \llbracket \text{crime} \rrbracket^c$ presumably for any value of c . Conversely, to the extent that we accept that $\llbracket \text{perfect crime} \rrbracket^c \subset \llbracket \text{crime} \rrbracket^c$, we have to consider it restrictive according to (150a) (which is not unproblematic, either).

As for pattern (I), the standard pattern, the adjective involved may have a restrictive reading in the sense of (150a):

- (157) þýski heimspekingur - inn (en ekki sá franskí)
 German philosopher - DEF but not the French one

This is especially evident from the fact that the adjective involved can be used contrastively; in (157), the adjective ‘German’ targets a proper subset in the denotation of ‘philosopher’ that is distinct from the proper subset targeted by ‘French’. But there does not have to be explicit comparison. We can say more generally that pattern (I) adjectives add information relevant to identifying a referent via descriptive content.⁵ In cases like (157), the thusly updated description can indeed be construed as a (proper) subset of the noun denotation.

However, we cannot categorically classify pattern (I) modifiers as restrictive, at least not under a strict interpretation of (150a). Consider the following example:

- (158) franskí forseti - nn ... en ekki rússneskí forseti - nn
 French president - DEF ... but not Russian president - DEF
 ‘the president of France’ ... ‘the president of Russia’

In examples like these, the adjective can be used contrastively without problems, and if contrastive reading is a diagnostic for restrictivity, it should be considered restrictive. Yet there is a subtle technical problem. For one thing, (158) cannot be parsed as involving intersective modification: if x is the French president (i.e. the president of France), it does not follow that x is French; the holder of that office could, at least in principle, be of a different nationality. What may seem more surprising, however, is the fact that examples of this kind cannot be subsumed under subsective modification either. The crucial thing to notice is that ‘president’ as used here is not a common noun denoting a set of individuals/a one-place predicate ($\langle e, t \rangle$), but a relational noun denoting a set of ordered pairs/a two-place predicate ($\langle e, \langle e, t \rangle \rangle$). The adjective, in turn, has a thematic reading and acts

⁵Recall also the various aspects discussed in section 3.1 where pattern (I) was contrasted with pattern (IV).

like an argument of the noun.⁶ Therefore, the entailment for subsectivity – $AN(x) \rightarrow N(x)$ – does not hold in a hairsplittingly technical sense. The ‘French_{thematic} president’ is not simply a president per se, but a president of something; existential closure is required:

- (159) a. $\Rightarrow [\text{French president}](x) \rightarrow \exists y [\text{president}(y)(x)]$
 b. **NOT:** $[\text{French president}](x) \rightarrow \text{president}(x)$

More broadly speaking, the set denoted by $\llbracket \text{French}_{\text{thematic}} \text{ president} \rrbracket$ is not simply a **subset** of the *set of presidents*, but an **element** of the *set of presidents of something*. This becomes evident if we represent the denotations as sets:

- (160) a. $\llbracket \text{French president / president of France} \rrbracket$: (PF)
 i. $= \{x \mid \text{president}(\text{France})(x)\}$
 b. $\llbracket \text{president (of something)} \rrbracket$: (P)
 i. $= \{\langle x, y \rangle \mid \text{president}(y)(x)\}$
 ii. $= \{y \mid \{x \mid \text{president}(y)(x)\}\}$
 iii. $= \{ \dots \{x \mid \text{president}(\text{Iceland})(x)\} \dots \{x \mid \text{president}(\text{Germany})(x)\} \dots \{x \mid \text{president}(\text{Russia})(x)\}, \dots \{x \mid \text{president}(\text{France})(x)\} \}$
 c. $\Rightarrow \text{PF} \in \text{P}$ (**BUT:** $\text{PF} \not\subseteq \text{P}$)
 $\Rightarrow \{\text{PF}\} \subseteq \text{P}$ (**BUT:** $\text{PF} \neq \{\text{PF}\}$)

Since the standard definition of restrictivity as given in (150a) crucially relies on subsective modification, it follows that thematic adjectives as in (158) cannot be considered restrictive.

Obviously, the brief superficial discussion in this subsection has not exhausted all the possible approaches to the notion (*non-*) *restrictivity* that have been proposed in the literature, but it has illustrated two things:

(i) (*non-*) *restrictivity* is a rather elusive notion and it is not immediately clear which empirical phenomena it should capture in the first place; also we have seen that modifiers may be *not* restrictive for quite different reasons.

(ii) it does not seem to be possible to characterize patterns as a whole, at least not as (not/non-) restrictive. What we have found is this:

- (161) a. Pattern (III): modifier is not restrictive
 b. Pattern (II): modifier may be not restrictive; may be non-restrictive; may be restrictive(?)
 c. Pattern (I): modifier may be restrictive; may be not restrictive; ?

⁶I will discuss examples of this kind more thoroughly in section 4.2.1, and abandon this line of reasoning. The problem for restrictivity remains, though.

In the next subsection, I will try to approach some of the aspects mentioned above from a slightly different angle.

4.1.3 Non-Referentiality and Uniqueness

It has been noted in the literature that pattern (II) noun phrases are referentially deficient. (Julien 2005a:57), for instance, observes that “a nominal phrase with a prenominal determiner [= ART] is not necessarily referential”, (Sigurðsson 2006:195) points out that “[t]he preposed free article [= ART] is mostly confined to abstract nouns in formal written style”, and (Delsing 1993:121) states that “the form with the prenominal article [= ART] is not possible when the noun phrase has deictic reference [...] In such constructions the prenominal article is impossible even in literary style.”

Broadly speaking we can distinguish two cases of non-referentiality, and those basically correlate with (the) two prototypical uses of pattern (II): *concept formation* and *anaphora*.

As for the former, what I call a *concept* here is a cover term for complex A N descriptions that make reference to abstract notions (“platonic forms” or ideas if you will) or generic phenomena/(Carlsonian) kinds:

- | | | |
|-------|--|--|
| (162) | a. hinn fullkomni glæpur
ART perfect crime | e. hin íslenska tunga
ART Icelandic tongue |
| | b. hin eilífa æska
ART eternal youth | f. hin hefðbundna fjölskylda
ART traditional family |
| | c. hinn þögli meirihluti
ART silent majority | g. hinn almenni borgari
ART common citizen |
| | d. hin vísindalega aðferð
ART scientific method | h. hinn út dauði dúdú-fugl
ART extinct dodo-bird |

What is specifically non-referential about these cases is that they do not make reference to an individual, but rather to a superordinate abstract concept/kind.

Pattern (III) cannot be used to denote kinds or abstract phenomena; it can only make reference to individuals.⁷ Therefore the pattern (III) versions of (164) are categorically deviant. With pattern (I), things are a bit more complicated; it can certainly make reference to individuals like pattern (III). But as the standard pattern, it does have a wide range of uses. For one thing, pattern (I) noun phrases as such may – differently from pattern (III) – be used to denote kinds :

⁷This will be shown in more detail in section 4.2.3.

description ‘known actor’. Note that pattern (III) is perfectly fine in the attributive epithetic use as well:

- (166) a. leikari - nn þekkti Clint Eastwood
 actor - DEF known C. E.
 b. hljómsveit - in vinsæla 4 x 100
 band - DEF popular 4 x 100

One crucial condition for what I call anaphoric epithets is that a referent has been introduced into the discourse, typically by name, and/or is uniquely salient. We find the same distribution as above, pattern (I) is bad, but patterns (II) and (III) are fine:

- (167) Noam Chomsky var fenginn í viðtal við MBL.
 N. C. was gotten in interview with MBL (an Icelandic newspaper)
- a. #Frægi málfræðingur - nn ...
 famous linguist - DEF
- b. Hinn frægi málfræðingur ...
 ART famous linguist
- c. Málfræðingur - nn frægi ...
 linguist - DEF famous
- (... sagðist vera mjög ánægður með nýjustu bókina sína)
 ‘The famous linguist’ (... said that he was very pleased with his latest book)

Anaphoric epithets can be characterized as placeholders denoting a (purportedly) known property of a known referent. In other words, they do not establish a new discourse referent via their descriptive content, but are merely anaphorically linked to a referent that is already known. Their distribution is thus similar to that of simple (unstressed) pronouns (see for instance Postal 1972). So we can paraphrase (167) as follows:

- (168) [Noam Chomsky]₄ ...
 a. he₄ said that he₄ was very pleased
 b. he₄ is a famous linguist

Now it is interesting to note that unmodified definite noun phrases can also be used as epithets:

- (169) a. leikari - nn Clint Eastwood cf. (165a)/(166a)
 actor - DEF C. E.
 b. [Noam Chomsky]₄ ... cf. (167)
 málfræðingur - inn sagði að ...
 [linguist - DEF]₄ said that ...

- (ii) pattern (II) noun phrases by themselves can make reference to kinds and abstract concepts; they can make reference to individuals if they are anaphorically linked to a unique salient referent. They are not, however, capable of deictic reference in that they cannot identify a referent via descriptive content. The adjective may add substantial information to the descriptive content that must satisfy the uniqueness presupposition ('traditional family') or it may merely add an evaluation ('famous linguist').
- (iii) pattern (III) modifiers can only make reference to individuals. The adjective does not provide referentially relevant information that may contribute to identifying a referent or defining the description that must satisfy the uniqueness presupposition, but merely adds backgrounded (evaluative) information.
- (iv) unmodified definite noun phrase may be used anaphorically in that they merely co-refer with a given uniquely salient referent, or they may be used deictically in that the descriptive content of the noun may serve to identify a referent.

4.2 The Three Zones for Weak Adjectives

In this section, I will take a closer look at the internal architecture of the weak patterns, and show how primary semantic readings and structure correlate.

4.2.1 Thematic and Predicative Readings of Nationality Adjectives

In this subsection, I will examine two readings of nationality adjectives, which I will refer to as *provenance* reading, and *thematic* reading. In order to avoid confusion, I will give a brief clarification the latter notion. The term *thematic adjective* as used in the literature (for instance Cinque 1994, 2010; Bosque and Picallo 1996; Alexiadou and Stavrou 2005, 2011) typically refers to an adjective that modifies a deverbal noun and receives that thematic role the underlying verb would normally assign to a DP argument:

- (171) l' invasione *italiana* dell' Albania
 the invasion Italian of Albania
 'the Italian invasion of Albania' (Cinque 1994:86)
 (~ 'the invasion of Albania by Italy/the Italians')

In Icelandic, this use of adjectives is bad (or at least strongly degraded), cf. (172); the agent in such cases is normally expressed by a genitive DP, cf. (173):

- (172) a. #[?]ítalska árás - in á Albaníu (I)
 Italian attack - DEF on Albania

- b. #[?]hin ítalska árás á Albaníu (II)
 ART Italian attack on Albania
- c. #árás - in ítalska á Albaníu (III)
 attack - DEF Italian on Albania
- (173) árás Ítala / Ítalíu á Albaníu
 attack Italians-GEN / Italy-GEN on Albania
 ‘the attack on Albania by the Italians / Italy’

I will not be concerned with this kind of example; instead I will look at cases involving non-deverbal relational nouns expressing an office like ‘president’:

- (174) the French president
- a. ‘the president of France’ THEMATIC (non-predicative)
- b. ‘the president who is French’ PROVENANCE (predicative)

When talking about a thematic adjective, I will be referring to a nationality adjective as used in (174a) – rather than in (171).

For starters, let us have a look at the following example:

- (175) a. franskur heimspekingur - inn c. heimspekingur - inn franskur
 French philosopher - DEF philosopher - DEF French
- b. hinn franskur heimspekingur
 ART French philosopher

All three examples in (175) are synonymous in one relevant sense:¹¹ the adjective has a predicative provenance reading. That is, one way or another, all three examples denote a certain *x* such that *x* is (was) a philosopher and *x* is (was) French – for all weak patterns. Note that the head noun ‘philosopher’ falls under the broad category *common nouns*, which are usually construed as one-place predicates ($\langle e,t \rangle$): λx . philosopher(*x*). Now consider this example:

- (176) a. franskur forseti - nn c. forseti - nn franskur
 French president - DEF president - DEF French
- b. hinn franskur forseti
 ART French president

As in (175), we still find, in principle, the predicative reading with all three patterns: *x* is a president and *x* is French. The crucial difference is that this

¹¹In this subsection, I will ignore the subtleties and potential differences that were discussed in the previous section such as the referential status of the noun phrase (deictic vs. anaphoric) and information structure (as well as stylistic differences).

reading is not the most salient or natural one for pattern (I). Without a specific context, the most salient reading for (176a) is the thematic reading of the nationality adjective: x is the *president of France*. On the contrary, this reading is not available for patterns (II) and (III) at all; in (176b/c) the adjective involved can only express provenance.

The most obvious difference to (175) is the status of the head noun in (176). Nouns like ‘president’ are known as *relational nouns*, which are normally construed as two-place predicates ($\langle e, \langle e, t \rangle \rangle$): $\lambda y. \lambda x. \text{president}(y)(x)$ (= x is president of y). Only after the addicity is reduced, i.e. when the first argument slot is saturated, an originally relational noun will receive the status of a common noun: $\lambda x. \text{president-of-something}(x)$. In the present case, it seems as though the thematic adjective ‘French’ saturates the first argument slot of the relational noun ‘president’. In other words, the level of semantic correspondence in the above examples is not simply $[\textit{philosopher}] \leftrightarrow [\textit{president}]$, but rather $[\textit{philosopher}] \leftrightarrow [\textit{French president}]$. Obviously, this semantic insight has repercussions for the structure.

In the following, I will sketch an analysis that takes the semantic type of relational nouns seriously – for the sake of illustration. Several aspects will be revised and modified in the following subsections. Assume that locus of common noun denotation ($\langle e, t \rangle$) is nP ; assume further that a potential argument of the head noun has to be licensed/merged inside nP . For the moment, I will assume that thematic adjectives have the semantic type $\langle e \rangle$. With this in place, the common noun component of the above examples can be represented as follows:

- (177) a. $[_{nP} \textit{philosopher}]_{\langle e, t \rangle}$
 b. $[_{nP} \textit{French}_{\langle e \rangle} [\textit{president}]_{\langle e, \langle e, t \rangle \rangle}]_{\langle e, t \rangle}$

Now, given (177) and the fact that only the predicative provenance reading is available with common nouns like ‘philosopher’, it follows that that reading is related to the adjective’s combining with a common noun denotation, i.e. with $nP_{\langle e, t \rangle}$, which will give us (178a) for (175), and (178b) for the predicative reading of (176):

- (178) a. $[_{AP} \textit{French}_{\textit{provenance}}] + [_{nP} \textit{philosopher}]_{\langle e, t \rangle}$
 b. $[_{AP} \textit{French}_{\textit{provenance}}] + [_{nP} [\textit{president}]]_{\langle e, t \rangle}$

In other words, we have to assume that the two readings are the result of the adjective merging in different positions, inside and outside nP , respectively:

- (179) $[_{\alpha P} AP_{\textit{provenance}} [_{nP} AP_{\textit{thematic}} N_{\langle e, \langle e, t \rangle \rangle}]_{\langle e, t \rangle}]$

Recall that pattern (I), in principle, allows both the thematic and the provenance reading of nationality adjectives:

- (180) franski forseti - nn
 French president - DEF
 ⇒ the president of France THEMATIC
 ⇒ the president who is French (a Frenchman) PROVENANCE

This means that what surfaces as a pattern (I) DP in (176a) derives from two underlying structural sources, one in which the adjective is merged inside nP and saturates an argument position, and one in which the adjective is merged outside nP. Given my assumptions about the derivation of pattern (I), the corresponding surface structures can be represented as follows:

- (181) a. franski forseti - nn

- b. THEMATIC

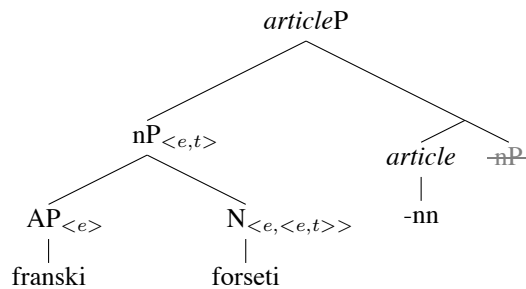

- c. PROVENANCE

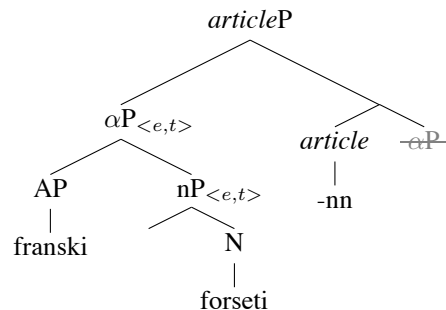

In case the adjective is merged inside nP, and thus has a thematic reading, only the nP moves to the pre-articular position. On the other hand, if the adjective is merged outside nP and has a provenance reading, the bigger constituent alphaP containing both AP and nP moves.

Pattern (II), on the other hand, only allows a provenance reading of nationality adjectives, but not the thematic reading:

- (182) hinn franski forseti
 ART French president
 ⇒ #the president of France THEMATIC
 ⇒ ^{ok}the president who is French (a Frenchman) PROVENANCE

Below the two assumed structures are given:

(183) a. hinn franskir forseti

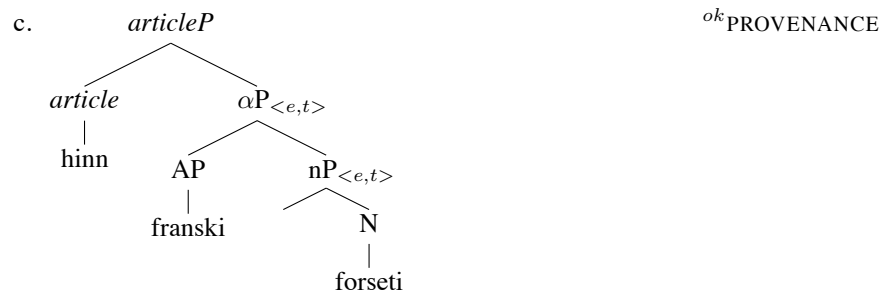
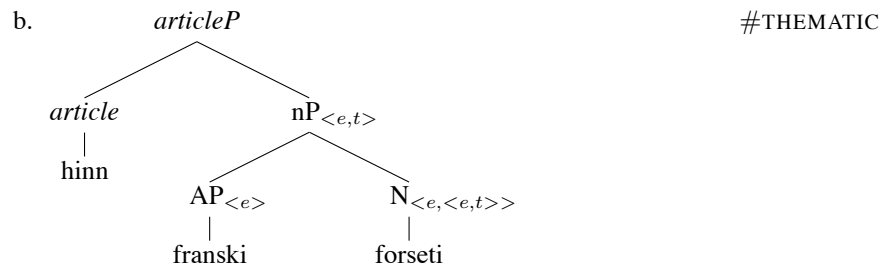

Pattern (III) behaves like pattern (II) insofar as only the provenance reading is available:

(184) forseti - nn franskir
 president - DEF French
 ⇒ #the president of France THEMATIC
 ⇒ ^{ok}the president who is French (a Frenchman) PROVENANCE

The respective surface structures for both readings are given in (185) below:

(185) a. forseti - nn franskir

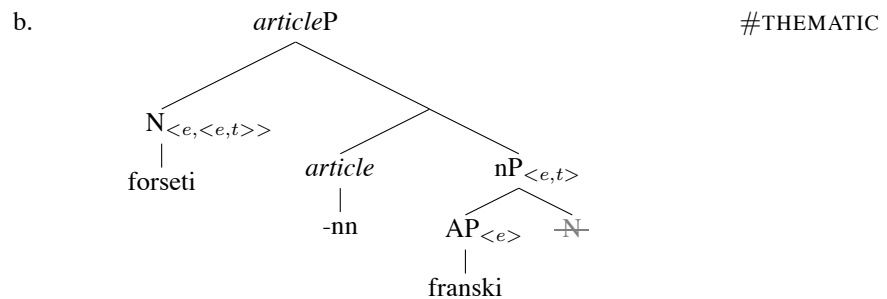

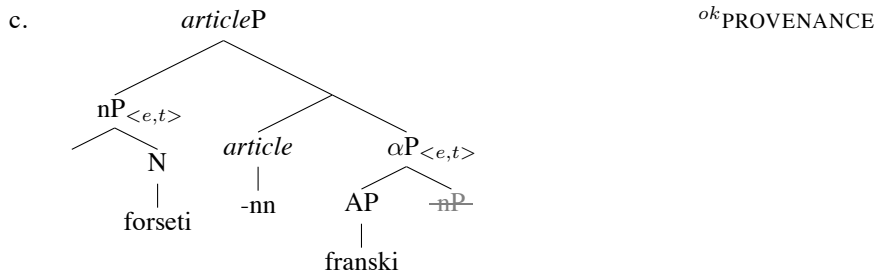

Given OAA, the structures in (183b/c) must also be assumed to be the input structures for the surface constellations in (181b/c) and (185b/c), respectively. Given that this analysis is on the right track, the unavailability of the thematic reading in patterns (II) and (III) can provide some interesting insights into the nature of ART and the moved nominal constituent. First of all, recall from section 2.1.1 that ART cannot be combined with a bare noun, but requires the presence of a prenominal modifier:

- (186) a. *hinn málfræðingur b. hinn frægi málfræðingur
 ART linguist ART famous linguist

The fact that the thematic reading is not available in pattern (II), however, suggests the (syntactically) proper use of ART does not merely depend on the presence of an adjective. I propose that those two phenomena are intimately related: the generalization then is not simply that ART requires the presence of a prenominal adjective, but that that adjective be merged sufficiently high, viz. outside nP. On this account, the thematic reading for (182) is not available exactly for the same reason (186a) is ungrammatical.¹² To my knowledge, this correlation has not been established in the literature before.

There is a different perspective: Since the thematic reading is available in pattern (I), and more to the point, since (I assume that) (181b) is derived from (183b), the latter cannot be considered ungrammatical as such. But as the contrast between the two suggests, movement of nP to Spec-*articleP* must be obligatory in this case. Furthermore, since movement is not obligatory if the nominal complement to *article* is “bigger” than nP, namely αP, cf. (183c), it seems as though we can state the generalization in terms of size of the nominal constituent: if the the nominal complement to *article* is below a certain size, it necessarily moves to Spec-*articleP*.

¹²Figuratively speaking, ART needs to “see” the prenominal modifier, but it cannot “see” inside nP, and given that thematic adjectives are merged inside nP, they are invisible to ART – just as if there were no adjective there to begin with.

The fact that (182) is not ungrammatical as such is due to the surface string allowing a construal that involves a sufficiently high modifier, which, in turn, yields the predicative reading, cf. (183c).

For pattern (III), we make the converse observation: Given the unavailability of the thematic reading, and given the assumed structure for that reading in (185b), one conclusion suggests itself: extraction out of nP is not well-formed. This conclusion has two aspects. On the one hand, nP-internal adjectives cannot be stranded, and on the other hand, the nominal constituent that moves to *Spec-articleP* cannot be smaller than nP. This would explain why the thematic reading is only available in pattern (I), not in pattern (III). On the other hand, on the licit provenance reading, nP moves to *Spec-articleP*, and the nP-external adjective is stranded in postnominal position, cf. (185c).

On this perspective, we find two size requirements: (i) if the nominal constituent is not bigger than x, it necessarily moves, and (ii) the nominal constituent must at least be of size y in order to move. In other words, adjectives must be merged above x in order for pattern (II)/ART to be syntactically well-formed, and adjectives must be merged above y in order to be able to be stranded. It is tempting to put x and y into the same equation, and identify nP as the constituent of the criterial size. After all, according to (183b/c), nP-external (but not nP-internal) adjectives can be considered a precondition for the well-formedness of ART/pattern (II), and according to (185b/c), only nP-external (but not nP-internal) adjectives can be stranded in postnominal position, which gives us pattern (III). Put the other way round, adjectives occurring in patterns (II) and (III), must not be merged below one certain position in the nominal spine, namely nP.

While I will retain the general idea of sizes being relevant for (non-) movement, unfortunately, we will have to abandon the specific idea that the size requirements are the same for patterns (II) and (III) as will be illustrated in section 4.2.3.

Before concluding this subsection, I would like to draw attention to a peculiar prediction the above sketched analysis makes. Given that nationality adjectives are merged (at least) in two different positions resulting in a thematic and a provenance reading, respectively, we expect it to be possible for both to occur simultaneously:¹³

- (187) a. norskí íslenski seðlabankastjóri - nn (I)
Norwegian Icelandic central-bank-chief - DEF
- b. hinn norskí íslenski seðlabankastjóri (II)
ART Norwegian Icelandic central-bank-chief
- c. íslenski seðlabankastjóri - nn norskí (I)+(III)
Icelandic central-bank-chief - DEF Norwegian

¹³Wrt. (187): The Norwegian Svein Harald Øygard held this office from February to August 2009. Wrt. (188): This is a somewhat unfortunate example, but it is straightforwardly applicable. Adolf Hitler was (an) Austrian by birth who occupied the office *chancellor of Germany*.

⇒ ‘the chief of the Central Bank of Iceland who is (a) Norwegian’

- (188) a. austurríski þýski kanslari - nn (I)
 Austrian German chancellor - DEF
- b. hinn austurríski þýski kanslari (II)
 ART Austrian German chancellor
- c. þýski kanslari - nn austurríski (I)+(III)
 German chancellor - DEF Austrian
- ⇒ ‘the chancellor of Germany who was (an) Austrian’

Given (179), the expected ordering is PROVENANCE >> THEMATIC, which is transparently displayed by patterns (I) and (II), cf. (187a/b) and (188a/b). Moreover, in accordance with what was said in section 4.1.1, this expectation is also borne out for mixed (I)+(III) patterns, cf. (187c) and (188c): the adjective stranded in postnominal position is merged higher than the prenominal one in mixed patterns. Given the specifics of the case at hand, in (188c), the pattern (I) component ‘German chancellor’ does not entail that the referent is a German, and the pattern (III) component ‘Austrian chancellor’ does not entail that the referent is chancellor of Austria. The structure for this example is given below:

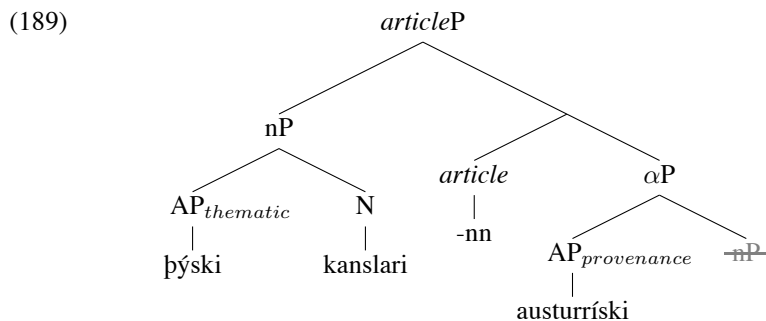

As an aside, note that we find an adjective with a thematic reading in a pattern (II) noun phrase in (187b) and (188b), so it cannot be categorically unavailable as was suggested in (182). Differently from that example, here we have an additional adjective with a provenance reading, which must, given our assumptions so far, be merged nP-externally. This observation suggests that the unavailability of that reading in (182) is not a consequence of ART or pattern (II) as such. Rather it confirms the idea that nP movement is not necessary if the nominal complement to *article* is bigger than nP:

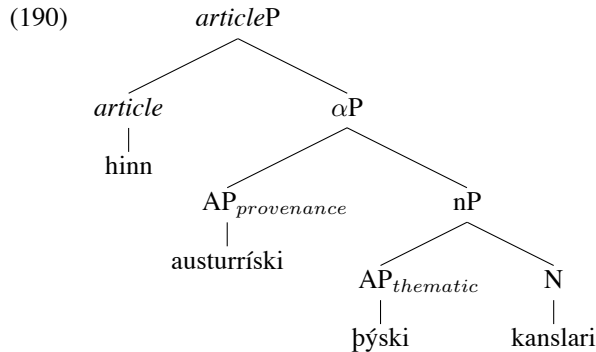

4.2.2 The Minimal Nominal Domain: nP

Note that swapping the adjectives in examples (187) and (188) leads to their opposite interpretation (‘the chief of the Central Bank of Norway who is Icelandic’ and ‘the chancellor of Austria who is German’). This is not surprising if the general ordering is indeed PROVENANCE >> THEMATIC. In many other cases, however, the unmarked ordering may, at least in principle, be reversed for scope or information structural reasons:

(191) unmarked ordering: SIZE >> NATIONALITY

- a. litli franskur heimspekingur - inn
little French philosopher - DEF
- b. hinn litli franskur heimspekingur
ART little French philosopher
- c. franskur heimspekingur - inn litli
French philosopher - DEF little

(192) marked ordering: NATIONALITY >> SIZE

- a. franskur litli heimspekingur - inn
French little philosopher - DEF
- b. hinn franskur litli heimspekingur
ART French little philosopher
- c. litli heimspekingur - inn franskur
little philosopher - DEF French

Even though not all of these examples sound equally natural, the adjectives have the same primary reading in both orderings. Notably, the nationality adjective has a provenance reading in both cases. On the other hand, in cases where the nationality adjective can potentially have a thematic reading, we find that this reading is only available if the adjective is adjacent to the noun. As soon as this adjacency

is interrupted by another adjective, that is if the nationality adjective precedes another adjective, it can no longer have the thematic reading, but only the provenance reading:

- (193) nationality adjective adjacent to noun:
 THEMATIC reading likely (PROVENANCE reading possible)
- a. litli franski forseti - nn
 little French president - DEF
 - b. hinn litli franski forseti
 ART little French president
 - c. franski forseti - nn litli
 French president - DEF little
 ('the little president of France' / 'the little president who is French')
- (194) nationality adjective not adjacent to noun:
 only PROVENANCE reading
- a. franski litli forseti - nn
 French little president - DEF
 - b. hinn franski litli forseti
 ART French little president
 - c. litli forseti - nn franski
 little president - DEF French
 ('the little president who is French' / #'the little president of France')

That is, the ordering PROVENANCE >> THEMATIC is rigid. The possibility of reversing the ordering in (191)/(192) may be attributed to both adjectives being merged outside nP. The impossibility of reversing the ordering while retaining the THEMATIC reading of the nationality adjective in (193)/(194), on the other hand, can be seen as a consequence of one adjective being merged inside nP, and the other one outside nP; nP defines a zone inside which the adjective is trapped as it were.

As for the status of “thematic” adjectives as they were labeled in the preceding subsection, I would like to propose a modification. The way they have been parsed, i.e. as expressions of type <e> suggests that they denote individuals just like DPs. As a matter of fact, this construal would be in line with the idea often proposed in the literature that “these adjectives have a nominal source, which is visible at the level of interpretation and this explains some of their properties” (Alexiadou and Stavrou 2005:2; see also Alexiadou and Stavrou 2011; Fabregas 2007).

For the purpose of this thesis, I will not follow this line of reasoning. In fact, I will not propose a specific analysis for thematic adjectives.¹⁴ Rather I will subsume

¹⁴Moreover, I will propose a different approach to relational nouns in chapter 7.

those under the broader heading *adjectives with an idiomatic reading*. In this, I basically follow Svenonius (2008) who proposes that “the n level is the level of lexical idiosyncrasy, so that idiomatically combined adjectives must attach below it” (op.cit.:36). The reason for this analytical decision lies in the data. We find many other examples that behave like the ones discussed in the previous subsection in one crucial respect:

- | | |
|---|---|
| <p>(195) a. ⇒ Hvíta hús - ið
white house - DEF</p> <p>b. hið hvíta hús
ART white house</p> <p>c. hús - ið hvíta
house - DEF white</p> | <p>(197) a. ⇒ kalda stríð - ið
cold war - DEF</p> <p>b. hið kalda stríð
ART cold war</p> <p>c. stríð - ið kalda
war - DEF cold</p> |
| <p>(196) a. ⇒ svarta belti - ð
black belt - DEF</p> <p>b. hið svarta belti
ART black belt</p> <p>c. belti - ð svarta
belt - DEF black</p> | <p>(198) a. ⇒ franska bylting - in
French revolution - DEF</p> <p>b. hin franska bylting
ART French revolution</p> <p>c. bylting - in franska
revolution - DEF French</p> |

Just like a thematic reading is only possible in pattern (I) in examples like (176), an idiomatic, non-compositional reading is only possible in pattern (I) in examples like (195) through (198). The pattern (II) and (III) noun phrases in these examples, on the other hand, necessarily have a compositional interpretation, and the respective adjectives have a predicative reading. To the extent that the pattern (II) and (III) versions are even acceptable or comprehensible,¹⁵ they are at least deviant in that they do not convey the idiomatic meaning.

Moreover, even in pattern (I), an adjective loses its idiomatic meaning if another adjective intervenes. For instance, *svarta skítuga belti-ð* ‘black dirty belt-DEF’ makes reference to a certain belt, but not to a degree of competence in the martial arts. As is the case with the thematic reading of nationality adjectives, cf. (193/194), adjacency with the noun is a requirement for the idiomatic reading of adjectives (see also Svenonius 2008:36/7).

In other words, I propose that we account for (195) through (198) the same way we accounted for the examples from the previous subsection: adjectives with a (non-predicative) thematic and a (non-compositional) idiomatic reading are both merged inside nP:

¹⁵It is not exactly obvious how to process a literal interpretation of expressions like ‘cold war’ or ‘French revolution’.

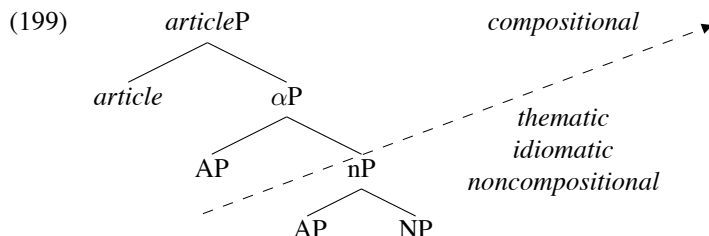

The nP projection can be seen as a criterial cut-off point in the extended nominal projection when it comes to modificational properties, and in this sense, nP constitutes a zone, a minimal conceptual domain.¹⁶

On a related subject, the fact that the adjectives in the examples considered in this section so far can have a predicative reading only if they are merged outside nP fits in with Svenonius' (2008) suggestion that "[m]odification of nP is essentially intersective" (op.cit.:38). However, we will see that what I call a predicative reading is more widely available; in particular, I will show that the adjectives with a predicative reading found in patterns (I) and (III) must be assumed to occupy two different structural positions.

4.2.3 Update: Another Zone above nP

At this juncture, let us briefly summarize the findings of this section so far. Only adjectives that are merged at a certain height in the nominal projection can be stranded, which gives us pattern (III), and only adjectives that are merged at a certain height in the nominal projection are "visible" to ART, i.e. license the syntactic well-formedness of pattern (II). Moreover, as the analysis stands currently, the examples considered so far suggest that those adjectives merged at "certain" heights *can* move along with the noun to the pre-articular position ending up in a pattern (I) configuration. On the other hand, adjectives that are merged below a certain height, viz. nP-internally, necessarily move along with the noun. Interestingly, the converse is also true: certain elements are merged so high in the structure that they never move along, that is, they never show up in pattern (I). The paradigm case is numerals:

- (200) a. *sjö höfuðsyndir - nar
 seven cardinal-sins - DEF
- b. hinar sjö höfuðsyndir
 ART seven cardinal-sins

¹⁶Henceforth, in cases where the internal make-up of nP is not relevant, I will simply use the label nP and ignore N(P).

- c. höfuðsyndir - nar sjö
cardinal-sins - DEF seven

Viewed from a different angle, if the nominal complement to *article* is not above a certain size, it necessarily moves, but at the same time, the moved nominal constituent cannot be below a certain size. So far, it seems as though the “certain” size is nP, and the “certain” height means nP-external, for all cases alike.

However, this assumption is too simplistic; certain adjectives can occur in patterns (I) and (II), but not in pattern (III). Consider the following examples:

- | | |
|--|---|
| <p>(201) a. íslenska tunga - n
Icelandic tongue - DEF
b. hin íslenska tunga
ART Icelandic tongue
c. #tungu - n íslenska
tongue - DEF Icelandic</p> | <p>(202) a. hefðbundna fjölskylda - n
traditional family - DEF
b. hin hefðbundna fjölskylda
ART traditional family
c. #fjölskylda - n hefðbundna
family - DEF traditional</p> |
| <p>(203) a. kaþólska kirkja - n
catholic church - DEF
b. hin kaþólska kirkja
ART catholic church
c. #kirkja - n kaþólska
church - DEF catholic</p> | <p>(204) a. efnahagslega hrún - ið
economic collapse - DEF
b. hið efnahagslega hrún
ART economic collapse
c. #hrún - ið efnahagslega
collapse - DEF economic</p> |

In section 4.1.3, we looked at examples of this kind and I pointed out that pattern (II) noun phrases (proto-) typically refer to kinds/concepts, pattern (I) noun phrases may refer to kinds/concepts, but pattern (III) noun phrases cannot refer to kinds/concepts. Let us have a look at this same phenomenon from the point of view of the adjective.

Adjectives in examples like these are typically referred to as relational or classificatory; McNally and Boleda (2004) argue that relational adjectives are properties of (Carlsonian) kinds and “fall into the same sortal class as adjectives like *widespread* or *extinct* in English” (op.cit.:188). The fact that patterns (I) and (II) are well-formed then suggests that the adjectives in these patterns can act as kind modifiers and modify kinds. Conversely, the fact that pattern (III) is bad suggests that adjectives in this pattern cannot modify kinds. In other words, pattern (III) adjectives can only act as predicates over individuals, but not as predicates over kinds.¹⁷ This can be illustrated nicely with the following example; adjectives like ‘extinct’ can only be used as a predicate over kinds, but not over individuals.

¹⁷So (203c) could, in principle, be used when talking about a specific church (building), rather than the institution.

The pattern (III) example in (205a) produces the same anomaly as example (205b) where *extinctness* is predicated of a specific individual:

- (205) a. #dúdúfugl - inn útdauði
 dodo-bird - DEF extinct
 b. #Didi the dodo / this dodo (over there) is extinct

It has been proposed that there is a specific layer for (Carlsonian) kinds in the noun phrase (most prominently Zamparelli 2000), call it *kindP* for the time being (I will revise that label in section 4.3 below). Kind-modifying adjectives have to be merged inside *kindP*. With this assumption in place, we can represent (201a/b) as follows:

- (206) a. (I)
- ```

graph TD
 articleP[articleP] --- kindP[kindP]
 articleP --- article[article]
 kindP --- AP[AP]
 kindP --- nP[nP]
 AP --- islenska[íslenska]
 nP --- tunga[tunga]
 article --- n[-n]
 article --- kindP_crossed[kindP]

```
- b. (II)
- ```

graph TD
  articleP[articleP] --- article[article]
  articleP --- kindP[kindP]
  article --- hin[hin]
  kindP --- AP[AP]
  kindP --- nP[nP]
  AP --- islenska[íslenska]
  nP --- tunga[tunga]
  
```

This construal, in turn, has serious implications for pattern (III). If *kindP* really marks the close-off point of the kind-denoting domain such that kind modifying adjectives have to be merged inside *kindP*, then given the badness of pattern (III) in (201) through (204), we have to conclude that visibly *kindP*-internal modifiers cannot be stranded. More specifically, given that height of merger is the decisive criterion for strandability, we have to conclude that an adjective must not merely be nP-external, but, in fact, *kindP*-external in order to be able to be stranded in post-nominal position. So the actual representation for an example like (175c) would be (207b), not (207a):

(207) a.

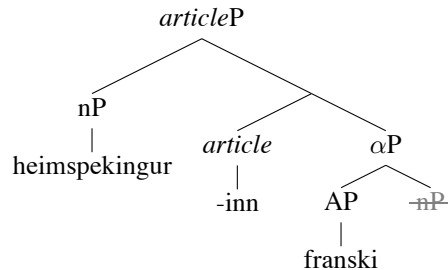

b.

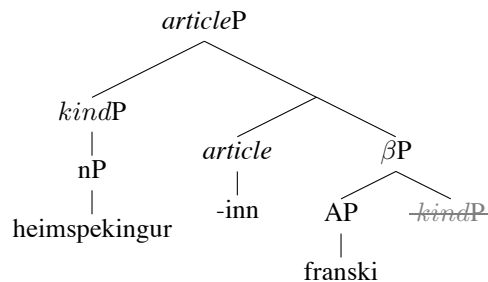

This means that the minimal height at which an adjective has to be merged in order for pattern (II) to be well-formed (above nP) is not the same as the height requirement for strandability (above *kindP*). Conversely, the minimal nominal constituent that moves to Spec-*articleP* must be assumed to be *kindP* and not nP; otherwise it should be possible to strand *kindP*-internal adjectives.

4.2.4 A Fresh Look at Patterns

With these modifications in place, it is obvious that the notion *pattern* is not a primitive; especially, patterns (I) and (III) involve adjectives that are merged in two different zones. This has ramifications for the semantic characterization of the patterns as given in section 4.1.3 above. Instead of talking about pattern (II) and pattern (III) modifiers separately, we can for instance subsume those modifiers that are fine in both patterns (II) and (III), but bad in pattern (I), as *kindP*-external modifiers. This goes, in particular, for those adjectives that I have characterized as evaluative:¹⁸

- (208) a. *frægi leikari - nn Clint Eastwood
 famous actor - DEF C. E.
 b. hinn frægi leikari Clint Eastwood
 ART famous actor C. E.

¹⁸Such as 'great', 'famous', 'brilliant', 'controversial' etc., see the examples in (54) in chapter 2. Example (208) is repeated from section 4.1.3.

- c. leikari - nn frægi Clint Eastwood
actor - DEF famous C. E.

This means that it is a property of *kindP*-external adjectives to express some evaluation/provide backgrounded information, rather than a property of a pattern. On my assumption, which will be further fleshed out in the next section, that *kindP*-external material does *not* move along, we have thus an account of why (208a) is bad: the adjective is merged too high. In other words, pattern (I) is bad with adjectives that have a genuine evaluative function because those are merged *kindP*-externally.

On the other hand, we cannot categorically say that pattern (I) is bad in the epithetic use, notably, if the adjective can reasonably be assumed to be merged *kindP*-internally:

- (209) a. ^{ok}bandaríski leikari - nn Clint Eastwood
American actor - DEF C. E.
b. ^{ok}þýski heimspekingur - inn Hegel
German philosopher - DEF H.

Incidentally, this example illustrates that pattern (I) noun phrases do not necessarily have deictic reference (which is incompatible with the epithetic use). Rather like unmodified definite noun phrases, they may have anaphoric uses as well.

More broadly speaking, the segmentation of *articleP* into three zones allows us to analyse the various properties of the surface constellations that I refer to as patterns on a more fine-grained level, and it is those zones that are responsible for the properties of the respective adjective, not the patterns themselves.

4.3 The Index Phrase

Baker (2003) argues that the distinctive property that sets nouns apart from other lexical classes like verbs and adjectives is that only the former have a criterion of identity and can set a standard of “sameness”. More specifically, he proposes that only nouns bear a referential index. That index is conceived of as an ordered pair of integers (notationally represented as subscript) where the first integer is a unique contribution of the noun, whereas the second integer “must be shared with something else in the syntactic structure” (op.cit.:104). An expression like $N_{\{j,k\}}$ reads “j is the same N as k”. In other words, the first integer is associated with the standard of sameness established by the noun, and the second integer allows referent tracking across the wider syntactic context/the discourse (thus the second integer is the index relevant for binding and co-indexing).

In this section, I will develop an analysis an analysis of *articleP* that incorporates the notion of a referential index. I will, however, modify certain aspects of Baker’s proposal.

4.3.1 The Referential Index

Baker argues that the index is a genuine property of the lexical category *noun*, i.e. N^0 . However, with reference to Marantz’s idea of category neutral lexical categories and the conception of ‘little n’ (Marantz 1997, 2000), he opens the possibility for a slightly different perspective: “My work can [...] be harmonized with this version of Marantz’s by saying that I have given the theory of the grammar of n, a and v, rather than N, A and V” (Baker 2003:269, fn. 2).

(Truswell 2004:23-26) takes up this thought and develops it further. He proposes that the index is actually introduced by a head he terms ‘Same’ (which roughly corresponds to Marantz’s n^0). He further argues that “the referential index is not atomic” (op.cit.:24), and that the two indices (i.e. integers) should not be introduced by the same head. The main motivation for this idea stems from the observation that adjectives dynamically update the standard of sameness. That is, the criterion of identity of a (bare) noun and that of a modified noun are not (necessarily) identical, most strikingly in the case of opaque adjectives: *thief* vs. *alleged thief*. He therefore proposes a second head (labeled ‘Ref’) that introduces the second index which allows referent tracking. Between those two heads, adjectives can be merged which dynamically update the standard of sameness established by Same^0 . After the merger of Ref^0 , no more updating is possible.

I will adopt this general idea. For one thing, I will assume that the first integer j , i.e. the “sameness component” of the index, is introduced by n^0 , which means that nP is the minimal structural object that does have a standard of sameness. Actually, this assumption was already made implicitly in section 4.2.2, cf. (199), where I characterized nP as a minimal conceptual domain inside which the core denotation of the nominal expression is determined. In addition, I propose that there is a higher projection where the second integer k , i.e. the referential component of the index, is introduced. I will call this projection simply *ixP* (mnemonic for *indexP*). An expression like $N_{\{j,k\}}$ on Baker’s conception will thus translate to the following structure:

$$(210) \quad \begin{array}{c} ixP_{j,k} \\ \swarrow \quad \searrow \\ \quad nP_j \\ \quad \swarrow \quad \searrow \\ \quad \quad NP \end{array}$$

In a manner similar to Truswell, I will assume that adjectives that are merged

between nP and *ixP* dynamically update the standard of sameness established by nP_{*j*}, whereas anything merged above *ixP*_{*j,k*} does not. I will, however, leave open the possibility that the second index may be updated by *ixP*-external adjectives.

Back to Icelandic; I propose specifically that *ixP* is the nominal constituent that moves to Spec-*articleP*, and that only modifiers that are merged above *ixP* can be stranded. Given the discussion in section 4.2.3, I thus explicitly identify *ixP* with *kindP*.¹⁹ This means that pattern (III) modifiers are categorically merged *ixP*-externally, and so are some pattern (II) modifiers, whereas pattern (I) modifiers are categorically merged inside *ixP* (possibly inside nP). Abstractly, we have the following distribution of (weak) patterns inside *articleP*:

(211) Distribution of weak patterns:

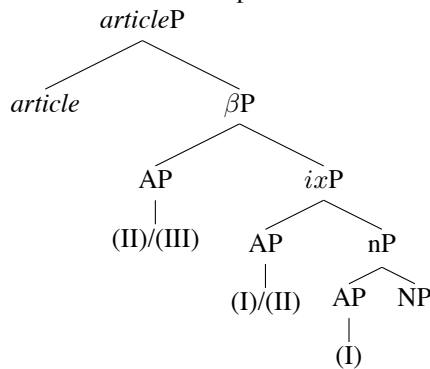

In the following, I will elaborate on some technicalities in more detail and show how these assumptions allow us to account for the data discussed above.

4.3.2 Interpretation of the Index

Assume that *j*, *j'*, *j''* ... are variables for objects of a certain sort, possibly something like Carlsonian kinds; the denotation of nP_{*j*} can then be given as in (212a). In (212b/c), I illustrate the mechanism of index updating:

- (212) a. $\llbracket \mathbf{nP}_j \rrbracket = \lambda j. \mathbf{nP}(j)$
 b. $\llbracket [_{\alpha P} \mathbf{AP} \mathbf{nP}]_{j'} \rrbracket = \lambda j'. \exists j. \mathbf{nP}(j) \ \& \ \mathbf{AP}(j, j')$
 c. $\llbracket [_{\alpha P} \mathbf{AP} [\mathbf{AP} \mathbf{nP}_j]_{j'}]_{j''} \rrbracket = \lambda j''. \exists j'. \exists j. \mathbf{nP}(j) \ \& \ \mathbf{AP}(j, j') \ \& \ \mathbf{AP}(j', j'')$

Every merger of an adjective dynamically updates the standard of sameness notationally indicated by successively adding a prime ($j \rightarrow j'$). In the c-example, *j''* is the “current” standard of sameness.

¹⁹Also (Truswell 2004:25) explicitly acknowledges a strong affinity between his ‘Ref⁰’ and Zamparelli’s (2000) KI⁰.

ix terminates the updating of sameness by existentially quantifying over the *j* variable and introducing a variable *k* of a new sort, possibly individuals, that is linked to the the standard of sameness via some relation *R*:

$$(213) \quad \llbracket ixP_{j,k} \rrbracket = \lambda k. \exists j. nP(j) \ \& \ R(k,j)$$

R can be interpreted in a way similar to Carlson’s realization function (Carlson 1977), roughly: *k* realizes the kind denoted by *j*.

As for the denotation of *articleP*, there are two general constellations we want to capture. Firstly, the component involving the suffixed article, i.e. *ixP*-DEF (with or without modifiers), is the general case of definite noun phrases; it can be deictic or anaphoric (in a sense, it behaves like a free pronoun). Secondly, pattern (II), i.e. ART *ixP*, basically has the properties of a bound pronoun: it is either anaphorically bound or generically bound. In (214), I give simplified representations to illustrate the general idea:

$$(214) \quad \begin{array}{l} \text{a. } \llbracket [articleP \ ixP_{j,k} \text{-DEF}] \rrbracket = \lambda k. \exists j. nP(j) \ \& \ R(k,j) \\ \text{b. } \llbracket [articleP \ \text{ART} \ ixP_{j,k}] \rrbracket \\ \quad \text{i. } = \exists j. nP(j) \ \& \ \llbracket R(k,j) \rrbracket \text{ } [k \rightarrow \text{Noam Chomsky}] \\ \quad \text{ii. } = \Gamma \ k. \exists j. nP(j) \ \& \ R(k,j) \end{array}$$

(214a) largely corresponds to a classical Fregean construal of definite description (see for instance Heim and Kratzer 1998): there is exactly one individual that satisfies the description established by *ixP*. In (214b-i), *k* is anaphorically bound, and the *articleP* does not get its reference by satisfying the descriptive content, but via assignment function (‘the famous linguist’). In (214b-ii), *k* is bound by the generic operator Γ , and denotes a kind/abstract concept (‘the perfect crime’).

4.3.3 *ixP* Movement and the Decomposition of the Article

The discussion so far can be summarized as follows: if *ixP* remains low, it is bound by some anaphoric/generic operator (it behaves like a dependent element and cannot have deictic force), if *ixP* is high, i.e. in Spec-*articleP*, it may have deictic reference (i.e. the descriptive content of *ixP* contributes to identifying a referent). Therefore, the nature of *ixP*-movement is of central importance for the analysis.

Above I suggested that it is *ixP* and only *ixP* moves to Spec-*articleP*, and I submit that this movement happens for a reason: it is triggered. Assume that the article carries a feature [**ix**]²⁰ that needs to be checked in a Spec-Head configuration:

²⁰The notation [**X**] for selectional (and more generally, uninterpretable) features is adopted from Sternefeld (2006).

k. In a sense, then, “h” is some small pronominal of category *ixP*.²² Assume further that it forms a chain with the lower *ixP*. The difference between *ixP*-movement to Spec-*articleP* and merger of “h” can thus be represented as follows:

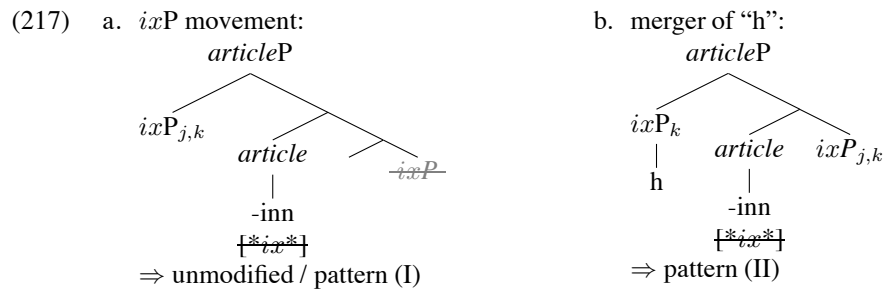

In (217a), the *ixP* in Spec-*articleP* carries a pair of indices, whereas the *ixP* (217b) only carries the index *k* which is linked to the index on the lower *ixP*. These two different syntactic configurations are brought about solely through satisfying the feature $[*ix*]$. On this approach, it is the configuration that is relevant for interpretation, that is, the semantic component interprets these two configurations differently, (217a) as in (214a), and (217b) as in (214b):

- (218) a. $\llbracket (217a) \rrbracket = \iota k. \exists j. nP(j) \ \& \ R(k,j)$
 b. $\llbracket (217b) \rrbracket$
 i. $= \exists j. nP(j) \ \& \ \llbracket R(k,j) \rrbracket^{[k \rightarrow N.N.]}$
 ii. $= \Gamma k. \exists j. nP(j) \ \& \ R(k,j)$

I will leave it open whether “h” itself makes a substantial contribution to interpretation, for instance whether it is “h” that is interpreted as operator, or whether it simply provides an index and thus creates a chain that needs to be bound by an external operator.

What has been said in this and the previous section was explicitly aimed at pattern (I) and pattern (II) noun phrases, and unmodified definite noun phrases. Implicitly, however, we have already all the ingredients for pattern (III) as well. Since it is *ixP* that is potentially attracted, *ixP*-external modifiers get stranded, in case *ixP* actually moves resulting in pattern (III) (or a mixed pattern). Trivially, if “h” is merged in Spec-*articleP*, nothing moves, and an *ixP*-external modifier remains in post-articular position as well.

The representation in (214a)/(218a) suggests that it is the descriptive content of of the proposed *ixP* that satisfies the uniqueness requirement imposed by the

²²This idea is in line with (Baker 2003:127) who proposes that pronouns have an index that consists only of one integer.

article. Being merged *ixP*-externally, pattern (III) adjectives thus do not fall under the radar of that requirement. This, in turn, coincides with *ixP*-external adjectives' inability to update the standard of sameness.

(219) a. *ixP* movement:

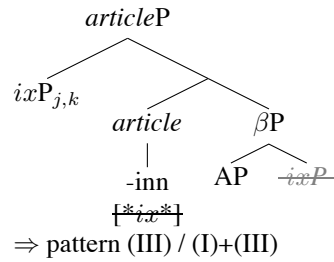

b. merger of “h”:

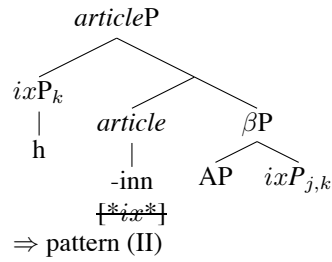

So in other words, *ixP*-movement in conjunction with the function of *ix* allows us to account for the primary properties of pattern (III) adjectives (“backgrounded”, not restrictive, not being able to modify kinds, not contributing descriptive content that must satisfy the uniqueness requirement).

4.3.4 The Shape of Trees to Grow

Let us have a look at some examples; for the ease of exposition, I will include a projection αP in order to illustrate where updating takes place:

(220) a.

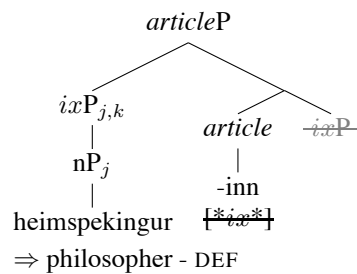

unmodified

b.

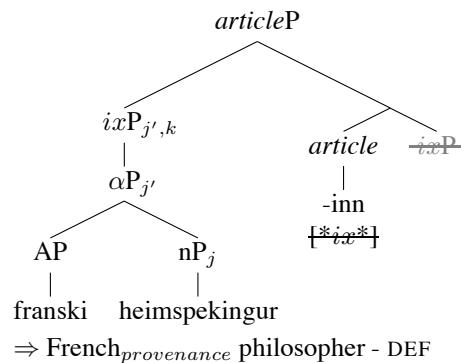

(I)

c. (II)

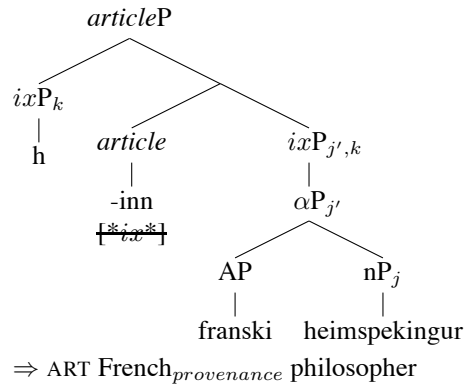

d. (II)

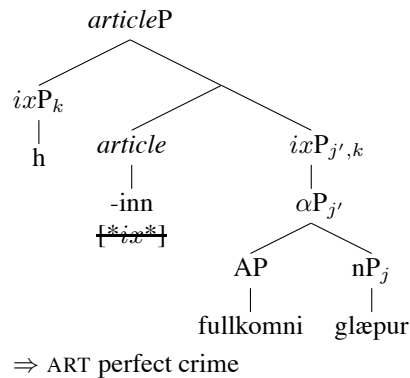

In (220a/b), ixP moves to Spec- $articleP$, in the former case, it contains an unmodified noun, in the latter, a noun plus ixP -internal modifier. In (220c/d), on the other hand, ‘h’ is merged, thus blocking ixP -movement. In the first two examples, ixP is interpreted in the high position and $articleP$ receives an interpretation as in (214a)/(218a). In the latter two, ixP is interpreted in its low base position and receives a bound interpretation; $articleP$ in (220c) receives an anaphoric interpretation as in (214b-i)/(218b-i), in (220d), it receives a generic interpretation as in (214b-ii)/(218b-ii).

Since no modifier is present in (220a), the standard of sameness (i.e. the index j) introduced by n is not updated. Examples b-d, on the other hand, involve an adjective that does update the standard of sameness as can be seen from the index on αP (j'). Below I give some examples involving ixP -external adjectives:

(221) a. (III)

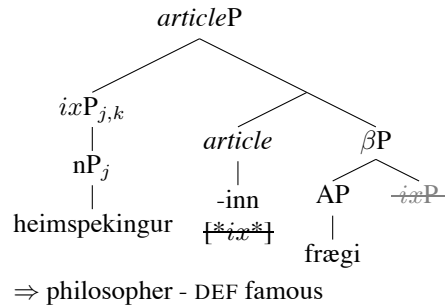

b. (I)+(III)

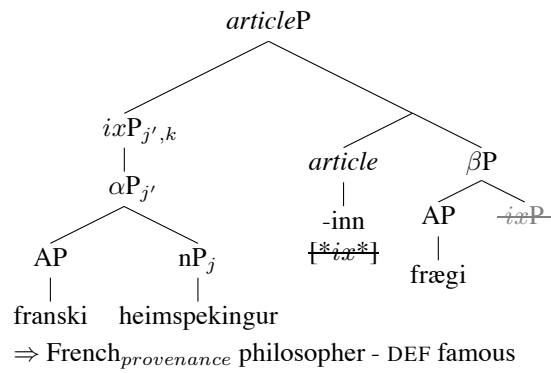

c. (II)

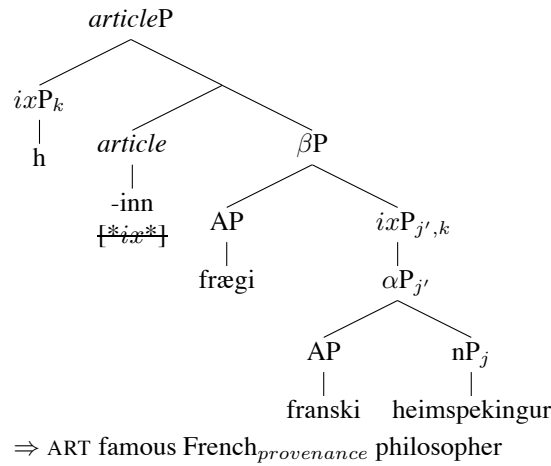

Even when *ixP*-movement does take place as in (221a/b), the *ixP*-external stranded adjective is not interpreted in the scope of the iota operator. That is, it is not part of the description that is subject to the uniqueness requirement. It merely adds a property conjunctively. Thus with the semantics of *ixP* and *articleP* in mind (see section 4.3.2), it seems as though our analysis can essentially generate

and interpret all examples discussed in this chapter – with one exception. There remains a particular problem that I will look at in the next subsection.

4.3.5 An Extra Restriction on the Free Article

The analysis as it stands can derive unmodified definite noun phrases, but also pattern (I) noun phrases involving a thematic adjective like *franski forsetinn* ‘the French president (= the president of France)’ (see the discussion in 4.2.1):

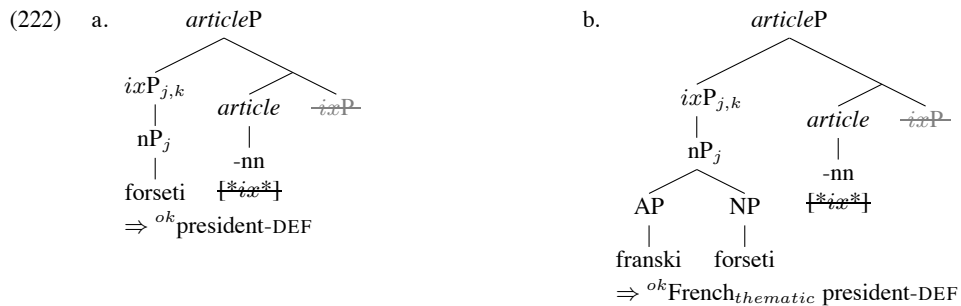

We can also account for the fact that the stranded adjective in a corresponding pattern (III) noun phrase cannot have a thematic reading: it is merged *ixP*-externally, whereas the thematic reading is only available *nP*-internally.

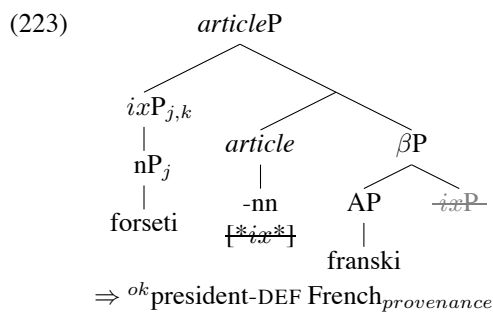

As was shown in section 4.2.3, the minimal height requirement for patterns (II) and (III) are not identical; that is, whereas pattern (III) modifiers are necessarily merged outside *ixP*, pattern (II) modifiers may be merged inside *ixP*, as long as they are merged outside *nP*. This fact is also captured by the analysis as it stands:

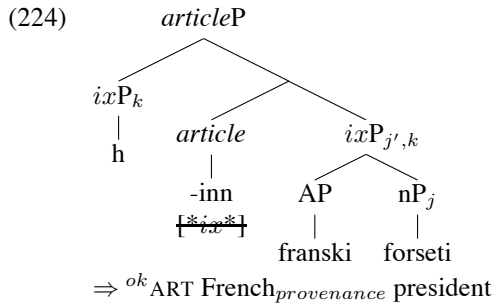

However, as long as the feature $[*ix^*]$ is the only driving force in the derivation, this requirement should simply be satisfied by merger of “h”, but as the discussion in 4.2.1 showed, ART is incompatible with a bare noun or with an nP-internal thematic adjective. Thus the following constellations are bad:

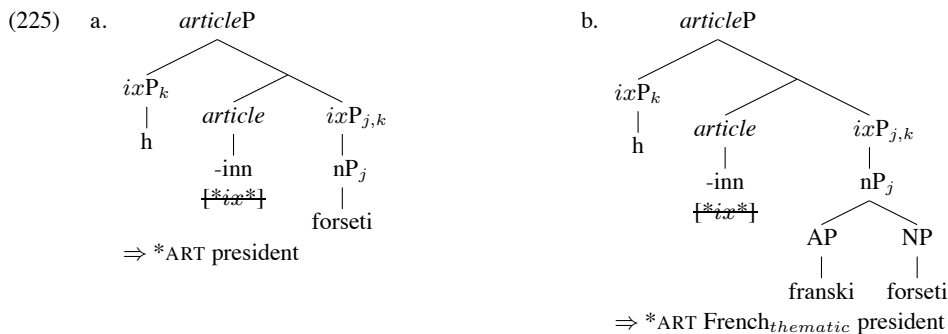

Note that this is independent of the interpretation of the noun phrase as a whole (or stylistic considerations). It is a matter of syntactic well-formedness of pattern (II) (or ART or “h”). In section 4.2.1, the problem was essentially put this way: the structural size of the *lexicalized* constituent that is the complement to *article* determines whether ART may be merged in the first place. If only nP is lexicalized – either by a bare noun or a low adjective plus noun – ART, i.e. merger of “h”, is not an option, but the nominal constituent must move: (225) vs. (222) Recall that *ixP* is motivated both on semantic and structural grounds. On the one hand, it introduces the referential index (that is, the second integer) which closes off the domain in which the standard of sameness can be updated and which is essential in establishing (deictic, anaphoric or generic) reference. On the other hand, it defines a zone where adjectives can be merged that surface either in pattern (I) or pattern (II), but not in pattern (III); that is, adjectives merged in this zone cannot be stranded. Therefore, I consider *ixP* a criterial position that is necessarily present in the extended nominal projection. The latter point is the reason why I abandoned the original idea proposed in section 4.2.1 that the moved constituent is merely nP.

We have also seen that pattern (II) is not only fine with nP-external/*ix*P-internal adjectives, cf. (224), but also with *ix*P-external adjectives and modifiers merged in CardP:

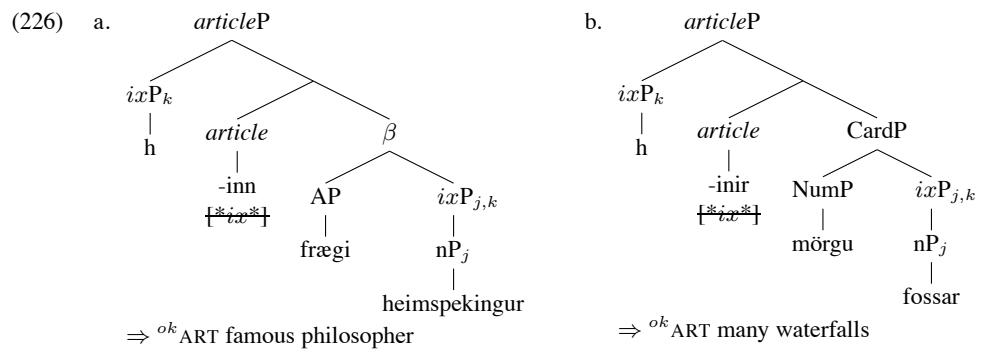

Descriptively, the generalization can then be formulated as follows:

(227) *Free Article Generalization:*

ART is licit, i.e. syntactically well-formed – in other words, “h” can be merged in Spec-*article*P – iff there is lexical material merged somewhere between nP and *article*⁰.

Potential positions for the relevant lexical items are indicated by ‘X’ in the following tree:²³

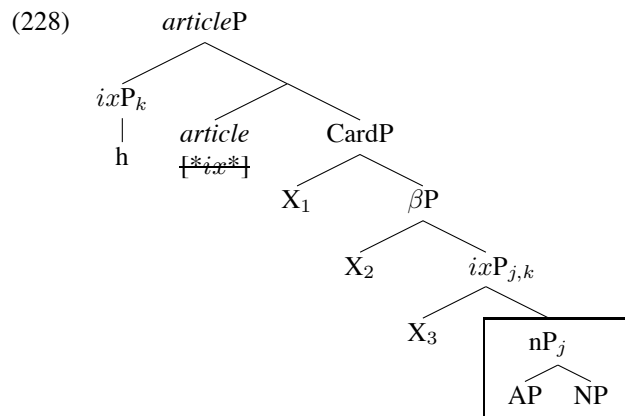

Note that this problem does not disappear on the alternative view that ART and DEF are distinct elements that may be merged in *article*⁰; we would still have

²³Recall from section 2.1.1 that this only applies to modifiers that surface in prenominal position like adjectives and numerals/weak quantifiers; postnominal modifiers such as relative clauses, PPs, and genitivals do not license the occurrence of ART.

to state that ART is sensitive to the structural size of (the lexicalized part of) its complement. In short, the presence/absence of the elements I labeled X_1 , X_2 and X_3 does have an impact on the syntactic well-formedness of ART/“h” on either view.

So the facts suggest that there is some intertwined interplay of the factors structural size of nP, *ixP*-movement to Spec-*articleP*, and the presence of X_1 , X_2 or X_3 . Let us formulate this a bit more nuancedly. Assume that n(P) is itself in need of licensing, and carries an unvalued feature [F:] which can be thought of as a property of the index j introduced by n. [F:] can be valued either in situ or in Spec-*articleP* (call the respective values *lo* for ‘low’ and *hi* for ‘high’ for simplicity). Let us further assume that the article element is the relevant valuer. So if nP surfaces in Spec-*articleP*, which is the case if *ixP*-movement has taken place, the feature is assigned the value [F:hi]. On the other hand, in those cases where the noun phrase surfaces as pattern (II), i.e. ‘h’ is merged and *ixP* stays put, that feature is valued in situ as [F:lo]. But in this latter case, there are certain locality conditions that must be satisfied for a successful valuation of [F:lo]. Let us have a look at the two scenarios in slow motion. (229a) represents the first-merge constellation; the requirement of [**ix**] – material of category *ixP* in the specifier position – is not satisfied, and the feature [F:] has no value. In (229b), *ixP* has moved to Spec-*articleP* thus checking off [**ix**]; the article surfaces as DEF. In this configuration, [F:] is valued as *hi*, thus the *articleP* is well-formed, cf. (229c):

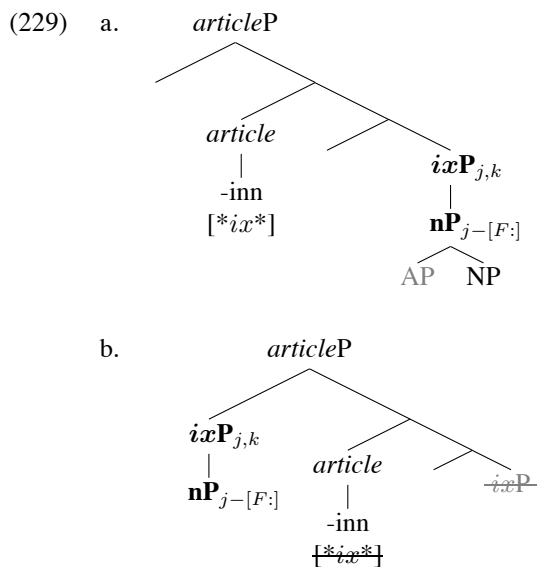

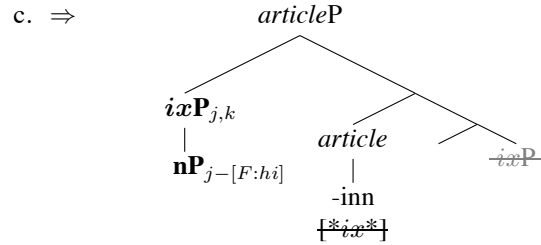

(230a) represents once more the first-merge constellation. In (230b), ‘h’ is merged in Spec-*articleP* thus checking off $[\ast ix\ast]$. Without lexical material between *nP* and *articleP* (X_1 , X_2 or X_3), however, the structure is not well-formed. I take this to mean that, in this configuration, $[F:]$ cannot be valued due to violation of some locality condition. Thus $[F:]$ does not receive a value and the derivation crashes, cf. (230c):

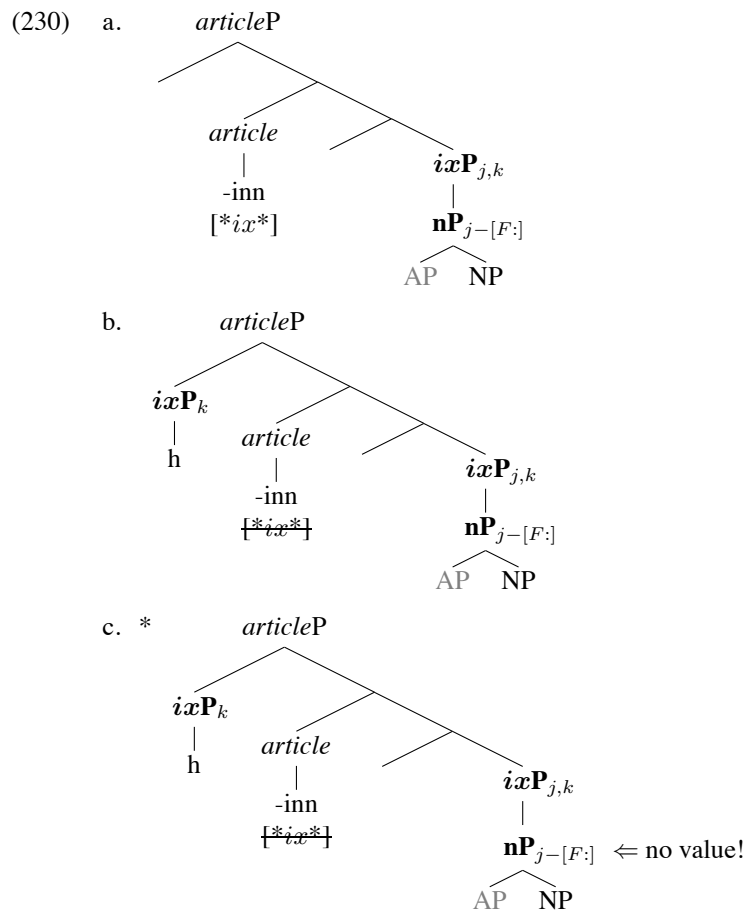

Conversely, since the presence of an element in X_1 , X_2 or X_3 does bring about a syntactically well-formed structure, they must be assumed to be involved in valuing [F:] as *lo*. They have a mediating function, as it were:

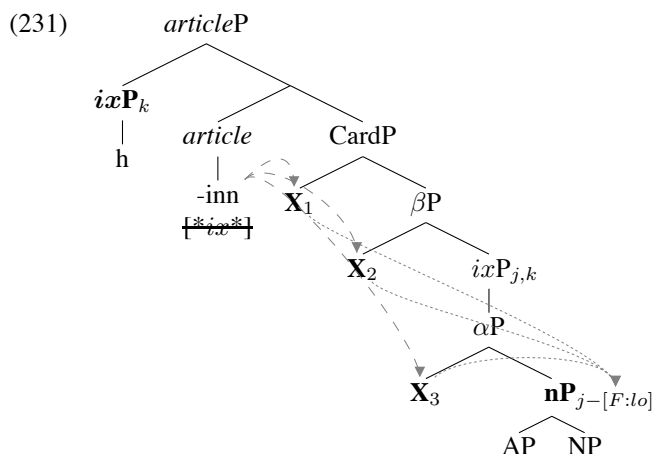

I will not attempt to elaborate on a technical implementation of this mediated valuation nor explore its deeper significance, but leave it at that. For the time being, [F:] should be considered a placeholder rather than the final analysis. The quintessence of this discussion is that one feature is not enough to account for the syntactically licit manifestations of the article while ruling out the illicit ones, and that there is something that seems to be sensitive to the presence of lexical material in X_1 , X_2 or X_3 in pattern (II) configurations. A feature like [F:] fills a gap, as it were, and suggests that not only DEF has requirements (as embodied by $[*ix*]$), but also the $n(P)$ is in need of licensing/valuing. On the one hand, [F:] can be parasitic on $[*ix*]$ in that ixP -movement brings about a constellation in which it can be valued, on the other hand, in a constellation where it cannot be directly valued, it relies on the presence of lexical material as mediator in being assigned a value.

4.4 Loose Ends

4.4.1 Indirect Modification?

In the previous chapter, I argued against the idea that weakly inflected adjectives should be analysed as syntactic predicates in a literal sense, and hence, a fortiori against their construal as RRCs in Cinque's (2010) sense. One may nonetheless ask whether we find evidence in Icelandic for the weaker idea that DP/*articleP*-internal adjectives divide into indirect and direct modifiers where indirect modifiers are

Uttered out of the blue, the most natural and salient reading of this example is the “Robin-Hood reading”; i.e. it is synonymous with (233a).²⁴ The fact that the adjective gets an absolute reading seems to favour an intersective interpretation, which would support a construal of *ix*P-external/pattern (III) modifiers as indirect modifiers. In other cases, however, this preference is less clear:

- (235) þjófur - inn hæfileikaríki
thief - DEF talented

In (235), it is not immediately obvious whether the referent is a thief who is talented in general or whether she is specifically talented as a thief,²⁵ in other words, whether the adjective receives an intersective or a subsective reading.

Recall from the introduction that I do not distinguish strictly between intersective and subsective interpretation to the extent that both can be subsumed as predicative reading. Descriptively, we can distinguish between absolute and relative predicative readings, as long as we conceive of those as indicating a gradual difference rather than a categorical one. Then we can characterize pattern (III) modifiers simply as having a predicative reading. This is presumably not what Cinque has in mind, but it could, in principle, still be reconciled with his conception of indirect modifiers, which are “possible in predicate position” (op.cit.:33). However, we also find adjectives in pattern (III) that are not possible in predicate position, for instance ‘so-called’:

- (236) a. afstæðiskenning - in svokallaða
theory-of-relativity - DEF so-called
b. *kenningin er svokölluð
theory.the is so-called
*‘the theory is so-called’²⁶

In addition, indirect modifiers on Cinque’s conception are restrictive, whereas *ix*P-external/pattern (III) adjectives are precisely *not* restrictive as has been pointed out several times in the course of this chapter.

So once again, we have to conclude that a certain group of Icelandic modifiers that seems to have in common some aspects with Cinque’s indirect modifiers cannot be construed as indirect modifiers in Cinque’s sense after all (recall the discussion of pattern (IV) appositives in section 3.1.4).

²⁴In fact, for many of my informants, this is the only reading.

²⁵According to my informants, both readings are, in principle, possible.

²⁶This should be kept apart from cases where ‘so’ has a strong deictic function and bears stress:

(1) ?the theory is **so** called (because ...)

As for *ixP*-internal modifiers (subsuming *nP*-internal modifiers), if anything, they are clearly direct modifiers. They are closer to the noun, they do not necessarily have predicative reading, and they do modify the reference²⁷ by their ability to update the standard of sameness.

4.4.2 Non-At-Issue Content?

Pattern (III) adjectives have been described as not restrictive, not contributing to reference, backgrounded, evaluative etc.. Especially the latter two aspects suggest that pattern (III) adjectives express some kind of (speaker's) comment about the referent, which, in turn, is one of the central properties of pattern (IV) appositives that were discussed in the previous chapter. We can indeed discern a strong similarity between patterns (III) and (IV). For one thing, both are merged *outside* a certain referential domain, outside *ixP* and outside *articleP*, respectively. Likewise, both lack a certain referential capacity and convey only backgrounded information and non-at-issue/CI content, respectively. In this sense, pattern (III) adjectives could indeed be conceived of as appositive-like, as a weaker version of pattern (IV) appositives.

The differences between the two – apart from their different structural location and adjectival inflection (weak vs. strong) – can essentially be described with respect to the properties they denote or the way they present them. Recall from section 3.1.2 that pattern (IV) appositives denote accidental properties or highlight circumstantial aspects of the referent. Pattern (III) adjectives, on the other hand, typically denote more “non-accidental”, i.e. substantial, characteristic or known properties (‘famous’, ‘brilliant’, ‘beautiful’, ‘controversial’ ...).²⁸

Nonetheless, one may ask whether the contribution of pattern (III) adjectives can be construed as CI content in Potts' sense. I will not pursue this question here, but submit that it is an issue that should be looked at more carefully.

A somewhat different question is the one on the status of epithets. As mentioned, in the literature, the term ‘epithet’ is often used for pejorative (or at least emotionally laden) expressions like “the bastard”, “the stupid thing”, “the idiot John” etc.. Potts (2003, 2005) classifies epithets with expressive modifiers, and hence analyzes them as conveying CI content.

²⁷Recall that Cinque identifies Bolinger's (1967) notion *reference modification* with direct modification.

²⁸This comes certainly close to characterizing the difference between pattern (III) adjectives and pattern (IV) appositives as a difference between IL predicates and SL predicates. But as already suggested in section 3.1.2, it is somewhat imprecise to characterize pattern (IV) appositives as SL predicates.

I have used term for more neutral, descriptive terms, but in terms of their semantic contribution, it seems as though they are amenable to a CI construal as well:

- (237) [... Noam Chomsky ...] *Hinn frægi málfræðingur* sagði að ...
 ... N. C₂ ... [ART famous linguist]₂ said that ...
 ⇒ **at-issue content** (referent): Noam Chomsky₂
at-issue content (proposition): he₂ said that ...
CI content (comment): he₂ is a famous linguist

Thus in terms of reference, expressions like “the famous linguist” are not really different from expressions like “the stupid idiot” in the cases under consideration. This suggests that it is indeed worthwhile pursuing a CI analysis of what I have been referring to as epithets. What is interesting – and challenging at the same time – in the present context is that this is a pattern-independent consideration. As we have seen, epithets are often instantiated by patterns (II) and (III), but also unmodified definite noun phrases and certain pattern (I) noun phrases are possible in this use.

4.5 Summary

This chapter has addressed a number of different issues concerning the weak patterns. We have, for instance, seen that mixed patterns and the fact that the (post-nominal/post-articular) pattern (III) component scopes over the (prenominal/pre-articular) pattern (I) component are not only compatible with OAA as outlined in sections 2.1.5/2.1.6, but furthermore support the idea of one high article position above numerals. With this assumption, we can derive all observable surface patterns accounting for both their linear ordering and their semantic properties in a simple and straightforward fashion. I have specifically argued for one movement operation, viz. *ixP* movement to Spec-*articleP*, where *ixP* itself can be seen as the demarcation line for the distribution of strandable modifiers. The broad generalization that emerges, then, is that *ixP*-external strandable modifiers scope over *ixP*-internal modifiers that move along (if *ixP*-movement occurs):

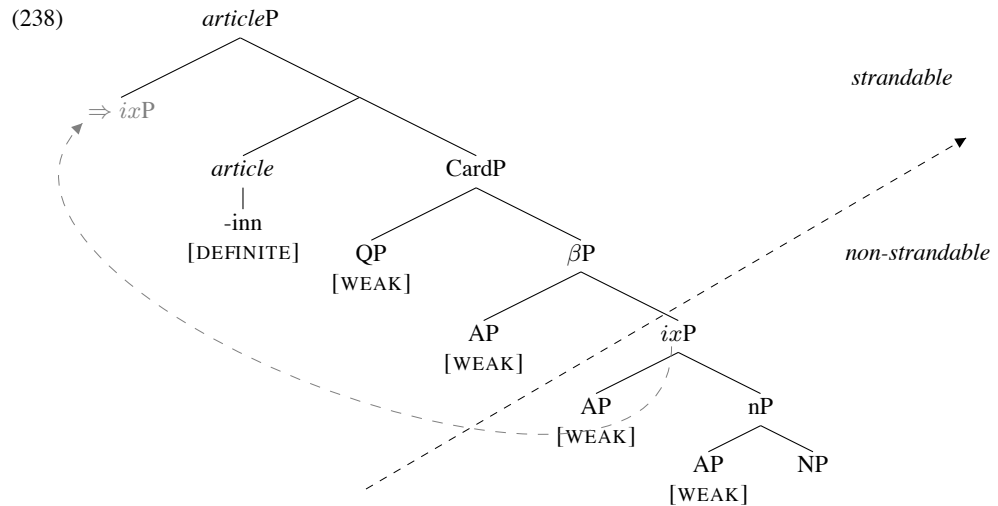

I have also argued that the constellation free article plus noun is ungrammatical for the same reason that certain readings associated with low nP-internal adjectives are not available. Therefore the proper generalization is not simply: ART requires the presence of an adjective, but more specifically: it requires the presence of a modifier that is merged above nP. Concerning the distribution of the free article, I have moreover argued that it is not, strictly speaking, DEF and ART that are in complementary distribution. Rather, ART can be decomposed into DEF and a morpheme 'h' that has the categorial status *ixP*, and it is basically 'h' and the nominal projection *ixP* that are in complementary distribution.

Examining various readings of adjectives, we have seen that the merge position of adjectives determines their semantic properties. More specifically, I have argued that we can distinguish three different zones. Here the notion of a referential index plays a decisive role. The lowest zone nP establishes a minimal standard of sameness; adjectives merged inside can have a thematic or a non-compositional idiomatic interpretation. Adjectives merged in the middle zone between nP and *ixP* contribute substantial, i.e. referentially relevant information and dynamically update the standard of sameness introduced by nP. Adjectives merged outside *ixP* cannot update the standard of sameness; the information they convey is not referentially relevant, but backgrounded. These aspects are summarized in the following tree diagram:

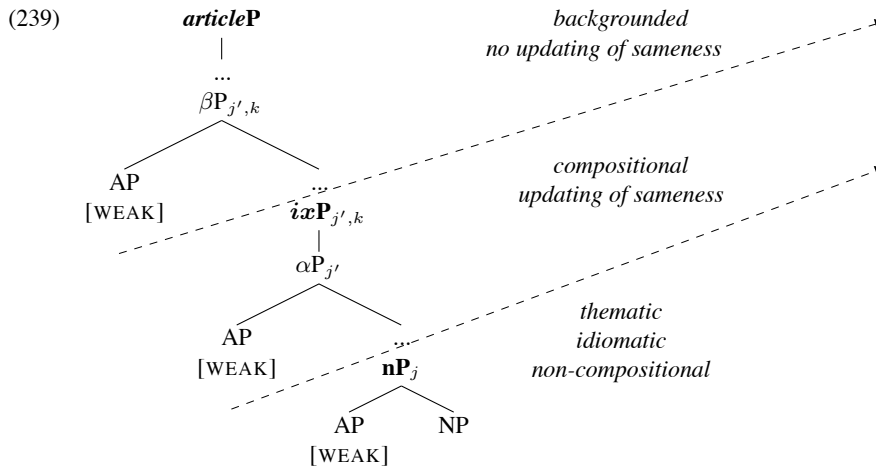

I have furthermore argued that a definite noun phrase with *ixP* in Spec-*articleP* can have deictic reference in that it can identify a referent via descriptive content, whereas a definite noun phrase with *ixP* in its low base position is bound either by an anaphoric or a generic operator:

- (240) a. $\llbracket [\text{articleP } ixP_{j,k} \text{-DEF}] \rrbracket = \iota k. \exists j. nP(j) \ \& \ R(k,j)$
 b. $\llbracket [\text{articleP ART } ixP_{j,k}] \rrbracket$
 i. $= \exists j. nP(j) \ \& \ \llbracket R(k,j) \rrbracket^{[k \rightarrow N.N.]}$
 ii. $= \Gamma k. \exists j. nP(j) \ \& \ R(k,j)$

The notion (*non-*) *restrictivity*, on the other hand, has proven to be less helpful than what has been suggested in the literature. We have seen that the very notion is problematic (notably, because modifiers can fail to be restrictive for different reasons), and that it does not provide an unambiguous criterion that correlates with pattern. In terms of zones, we could characterize *ixP*-external modifiers and *nP*-internal modifiers as *not* restrictive (albeit for different reasons), but it is not clear what this would achieve. As for *ixP*-internal/*nP*-external adjectives, they come close to the definition of restrictivity, if we equate their ability to update the standard of sameness with the concept of creating a proper subset in the noun denotation. We have, however, seen that the additional factor of *ixP*-movement vs. the absence thereof does have an impact on whether the thusly created subset is referentially relevant or not. Therefore, what is usually analysed in terms of (*non-*) restrictivity should rather be considered a complex phenomenon involving several factors such as the ones just mentioned (and possibly others).

Summary Part I

Part I of this thesis has been dedicated to the issue of adjectival modification in definite noun phrases. In chapter 2, I introduced four different surface patterns found in Icelandic. These patterns were scrutinized from various perspectives in chapters 3 and 4. One overarching goal has been to illustrate that the (definite) Icelandic noun phrase can be divided into four different zones:

(241)

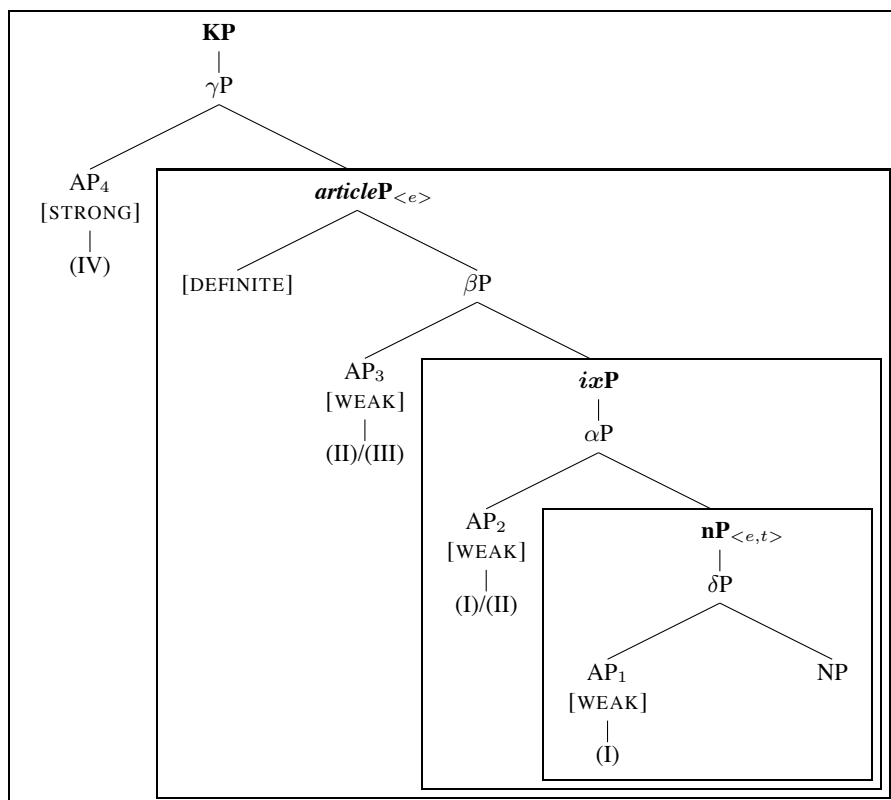

Those zones can be made visible in various ways by the four patterns. We have seen that adjectival inflection indicates a broad bipartition: strongly inflected modifiers are merged *outside articleP*, but *inside KP*, whereas weakly inflected modifiers are merged *inside articleP*. Among the *articleP*-internal adjectives, some can be stranded, which I take as an indication that those are merged *outside* a specific projection, viz. *ixP*. Many weakly inflected adjectives cannot be stranded, which suggests that they are merged *inside ixP*. Some non-strandable and thus *ixP*-internal adjectives are always merged closest to the noun, and no material can intervene between them. Those are merged in the lowest zone, namely *inside nP*. As illustrated in (241), there is no one-to-one correspondence between *pattern* and *zone*.

We have also seen that this morphosyntactic division correlates with semantic aspects: *nP* is the minimal conceptual domain that provides a standard of sameness; adjectives with a thematic or an idiomatic reading are merged inside *nP*. Adjectives merged between *nP* and *ixP* make a substantial contribution to the denotation of the noun phrase in that they dynamically update the standard of sameness set by *nP*. *ixP* is the domain of kinds; after merger of *ix*, the standard of sameness can no longer be updated. Adjectives merged outside *ixP* cannot modify kinds, but only individuals, and they cannot update the standard of sameness. The contribution they make can be characterized as providing backgrounded (evaluative) information. Modifiers merged outside *articleP* combine with or operate on a referential expression.

When looked at it this way, the intuition behind the subtitle of this thesis may become somewhat clearer. The dichotomy *inside* vs. *outside* runs like a leitmotiv throughout the discussion. A modifier that is merged inside *X* has an intimate relationship with the entity denoted by *X* which a modifier that is merged outside *X* lacks. The principle is the same regardless of whether *X* stands for *nP*, *ixP*, *articleP* and *KP*.

In section 1.1.2, I mentioned the proposal by Ramchand and Svenonius (2014) that certain zones in an extended projection be conceived of as sortal domains. I have not explicitly adopted this view, but proceeded on relatively traditional assumptions,²⁹ Implicitly, however, I have been drawing on the idea that each zone defines a different entity, that is, different sizes of nominal structure denote different entities. There are, in addition, some obvious parallels to that analysis, most

²⁹For instance: *NP/nP* is a set-denoting expression ($\langle\langle e,t \rangle\rangle$), and *articleP* is an object/individual-denoting expression ($\langle\langle e \rangle\rangle$).

strikingly, in the case of ixP , which can easily be understood as a *transition* in Ramchand and Svenonius' sense, namely, as the transition from the domain of kinds to the domain of individuals. If we try to spell out the implications more generally, we could re-construe the four zones illustrated in (241) as sortal domains, perhaps along the following lines: domain of concepts: nP ; domain of kinds: ixP ; domain of individuals: *article* P ; domain of referents: KP . Such a re-construal would have a number of ramifications for the system as developed so far and require some non-trivial modifications. For instance, *article* would have to be re-analysed as a transition function which not only existentially binds the individual variable, but also introduces a variable of a different sort (something like "referent"). I will leave an implementation of the technical details to further research, but suggest that my zones can indeed be construed as sortal domains.

Part II

**Genitivals, Possession and
Relations**

The previous chapters have sketched a detailed picture of several regions of the (Icelandic) noun phrase. Some findings may have come as a surprise, (for instance, the idea that some modifiers may be merged outside *articleP*/DP), others may be less surprising (*articleP*-internal modifiers are in full agreement with Greenberg's Universal 20: DET > NUM > ADJ > N, cf. Greenberg 1963; Cinque 2005).

When it comes to other core DP internal elements, however, things are more intricate. Often there is not much consensus in the literature to begin with. Case in point are possessive and genitival modifiers. One central question that has been given quite different answers is their precise location within the DP. As was already discussed in the introductory chapter, a considerable number of positions have been proposed in the literature – partly based on morpho-syntactic grounds, partly based on an assumed parallel between nominal and verbal projections (possessors as subjects). Another open question is whether empirically motivated (morpho-) syntactic distinctions correlate with semantic distinctions made on conceptual grounds (“possessor” vs. argument of N; common vs. relational head noun). In particular, we may ask whether there is a relationship between the syntactic position of the modifier and the semantic interpretation of the possessor.

An understanding of how genitival and possessive modifiers fit into the structure, how they interact with other DP internal material, and to what extent their interpretation is determined structurally is essential for any theory of noun phrase architecture. In addition, we find specific Icelandic issues that are of particular interest in the context of this thesis. These concern, notably, definiteness marking on the head noun (DEF) and/or adjectives (weak inflection) in possessive contexts (or the absence thereof), and the linearization of genitivals with respect to the article, numerals, adjectives and the head noun. To put it generally, the question is how genitivals behave as constituents of *articleP*, and alone for this reason, an investigation into the syntax and semantics of genitival and possessive modifiers is called for. In addition, the phenomenon of “genitive stranding”, which will be addressed in chapter 7 even seems to challenge a core tenet of the analysis developed so far, namely *ixP* movement. Therefore addressing these issues and showing how the challenge can be mastered is in the interest of the thesis itself

Chapter 5

Possession: Some Basic Facts

In this chapter, I provide some general background information and set the stage for the discussion to come. In section 5.1, I will outline some relevant technical aspects, in section 5.2, the basic data is introduced, and in section 5.3, I will briefly review some previous analyses of Icelandic (Scandinavian) GENITIVALS.

First of all, a clarification of the terminology used here is in order. The label GENITIVALS (in small caps) is used as a collective term comprising both full DP-genitives and pronominal possessives in cases where I do not distinguish between the two. Where the distinction is relevant, I will give those terms in italics: *DP-genitives* and *pronominal possessives*. When talking about their reference, I will follow common practice and refer to the referent of GENITIVALS as *possessor*, and the referent of the respective head noun as *possessum*. Moreover, I will refer to any N + GENITIVAL / GENITIVAL + N constellation as *possessive construction*. Finally, when talking about the semantic function of GENITIVALS, i.e. in terms of thematic role labels, I will use small caps (CONTROLLER/POSSESSOR, THEME, AGENT ...).

5.1 Background

In the context of this thesis, the most relevant aspects of GENITIVALS are their structural positions, their semantic relationship to their head noun (genuine possessor vs. argument), and their (non-) contribution to the definiteness of the noun phrase. In this section, I will briefly comment on the former two, whereas the latter aspect will be discussed separately in chapter 6.

5.1.1 Structural Positions of GENITIVALS

In section 1.3, I briefly discussed a number of potential merge positions and landing sites for GENITIVALS that have been proposed in the literature. The quintessence is that we find every structural option offered by X-bar theory: both X^0 and XP, both specifier and complement. The tree below, repeated from (39), summarizes those positions:

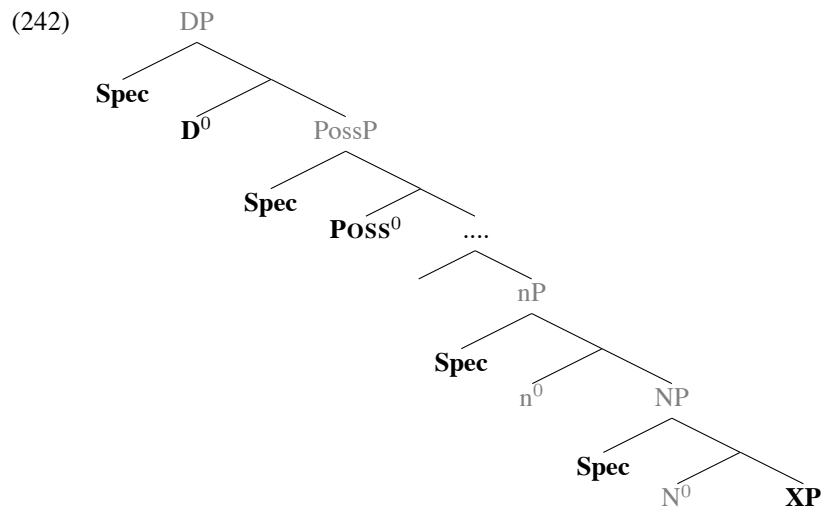

Broadly speaking, two perspectives can be distinguished. One focuses on the status of GENITIVALS as subjects. On this view, GENITIVALS are merged in Spec-NP/Spec-nP where they are assigned a theta role and then move to Spec-PossP where they receive (genitive) case (analogously to movement from Spec-VP/Spec-vP to Spec-TP).

The other perspective pays more attention to morpho-syntactic details such as the distinction pronominal vs. lexical *possessor*. On this view, (at least a subset of) *pronominal possessives* are assumed to be clitics or determiner-like elements that are merged in a head position and/or to carry some definiteness feature (see for instance Cardinaletti 1998; Schoorlemmer 1998; Ihsane 2000, 2003). Delsing (1993, 1998) makes a more general categorial distinction: *pronominal possessives* are merged in $POSS^0$ whence they may move to D^0 , and *DP-genitives* are merged as complements to N^0 , i.e. in the position labeled XP in (242).

I will adopt aspects of the latter view, whereas the otherwise prominent assumption that GENITIVALS have subject-like properties will play no significant role in the discussion to come. Delsing's proposal will be discussed in more detail in section 5.3.

latter group is supposed to team up with a member of the former group. In this context, (244a) can easily mean something like ‘John’s partner (who is *a* brother)’ without entailing that the two are siblings: $\iota x. \text{brother}(x) \ \& \ \mathbf{R}(\text{John})(x)$.

Note that there appears to be a problem for compositionality: in (244a), the *possessor* is construed as an argument of the noun (or rather as a participant in a relation denoted by the noun), and the GENITIVAL can be assumed to denote an individual ($\langle e \rangle$). This is not possible in (244b) because the head noun does not denote a relation. In other words, if the head noun has different types in (244) ($\langle e, \langle e, t \rangle \rangle$ vs. $\langle e, t \rangle$), the GENITIVAL “John’s” cannot have the same type in the a- and b-examples, respectively, either.

Partee (1997) approaches this issue by postulating two distinct *possessive constructions* with common nouns and relational nouns. In the former case, the GENITIVAL takes a common noun as argument and provides a free relation variable \mathbf{R} as part of its semantics, in the latter case, it takes a relational noun (which already denotes a relation by itself) as argument:

- (245) a. with common noun: free \mathbf{R} -variable
 $\llbracket \mathbf{Mary}'s_{DET_1} \rrbracket = \lambda P. \iota z. P(z) \ \& \ \mathbf{R}(\text{Mary})(z)$
 b. with relational noun: inherent \mathbf{R}
 $\llbracket \mathbf{Mary}'s_{DET_2} \rrbracket = \lambda \mathbf{R}. \iota z. \mathbf{R}(\text{Mary})(z)$

In order to account for certain *pronominal possessives*, I will adopt a modified version of Partee’s double specification.

The alternative given by Jensen and Vikner (1994) proceeds on the assumption that GENITIVALS have a uniform type and always combine with relational noun denotations. In order to achieve this, they propose that common head nouns are type-shifted. Barker (2011) calls this kind of type-shifter π , cf.:

- (246) a. $\llbracket \pi \rrbracket = \lambda P. \lambda y. \lambda x. P(x) \ \& \ \mathbf{R}(y)(x)$
 b. non-shifted N:
 $\llbracket \mathbf{car} \rrbracket = \lambda x. \text{car}(x)$
 c. type-shifted N:
 $\llbracket \pi \mathbf{car} \rrbracket = \lambda y. \lambda x. \text{car}(x) \ \& \ \mathbf{R}(y)(x)$

Even though these two analyses crucially differ in terms of where the relation \mathbf{R} is added in *possessive constructions* if the head noun is a common noun, both operate on the premise that the distinction between relational and common nouns is real.

A rather different approach is taken by Adger (2013) who attempts to abolish the notion *relational noun* altogether, and proposes instead that relationality is

“created” in the syntax. What this means is that he generalizes the type shifting analysis illustrated in (246c) to all nouns and syntacticizes it. Nouns like “brother” are treated as simple predicates like *car* in (246c). I will discuss and elaborate upon this analysis in section 7.2, and propose a modified version to account for *DP-genitives* and some *pronominal possessives*.

For descriptive purposes, I will make reference to the traditional distinction relational vs. common noun when discussing the Icelandic data, and moreover, I will use the labels *Inherent Possessive Relation* (IPR) (involving “argumental” GENITIVALS) and *General Possessive Relation* (GPR) (covering CONTROL/POSSESSION and *freeR*).

5.2 Possessive Constructions in Icelandic

In this section, I will give a general overview over Icelandic GENITIVALS. In subsection 5.2.1, I will briefly illustrate the inflectional properties of *pronominal properties*. In subsections 5.2.2 and 5.2.3, I will introduce the core data on *pronominal possessives* and *DP-genitives*, respectively, with a particular emphasis on the position of the respective GENITIVAL. It will emerge that we need to assume two structural locations, a high X^0 position that I will refer to as $POSS_1$, and a low XP position, $POSS_2$. These two positions, in turn, will have to be incorporated into the structure of the Icelandic noun phrase as established in the previous chapters, which is repeated below:

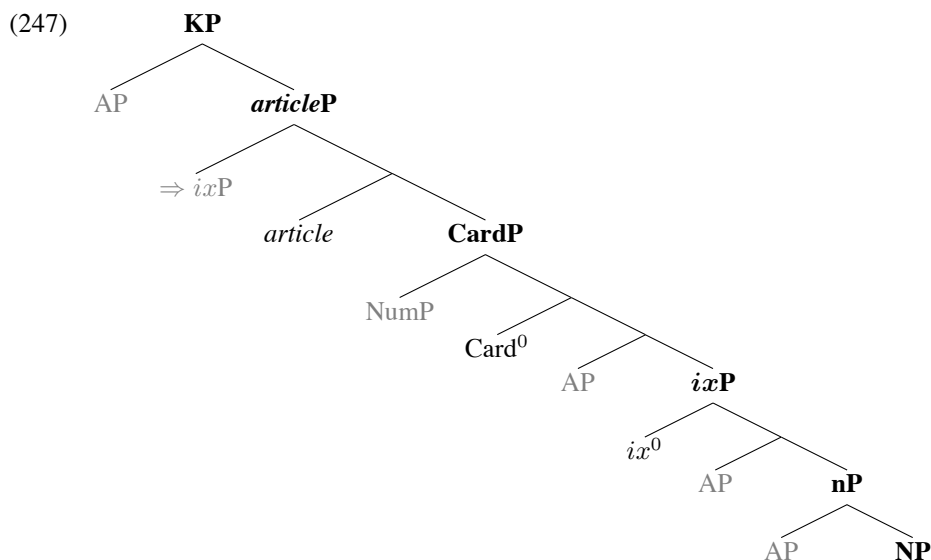

In 5.2.4, I will sketch a preliminary analysis of the high position $POSS_1$.

5.2.1 Formal Properties of *Pronominal Possessives*

Formally, *pronominal possessives* can be distinguished according to whether they are inflected, or not. Inflected *possessives* agree with the head noun in case, number and gender as in (248), whereas the non-inflected ones are invariably the genitival form of the corresponding personal pronoun as in (249):

- (248) a. Ég sá dóttur þín.a
I saw daughter.ACC your.FEM.ACC.SG
'I saw your daughter'
b. Ég hjálpaði syni þín.um
I helped son.DAT your.MASC.DAT.SG
'I helped your son'
- (249) a. Ég sá dóttur okkar
I saw daughter.ACC we.GEN
'I saw our daughter'
b. Ég hjálpaði syni hennar
I helped son.DAT she.GEN
'I helped her / their son'

In the third person, this distinction coincides with a referential aspect: the inflected form is reflexive and indicates that the *possessor* co-refers with/is bound by a c-commanding subject, cf. (250a), whereas the genitival form indicates that the *possessor* has a reference distinct from the subject, cf. (250b):

- (250) a. Hann elskar konu sín.a
He loves wife.ACC POSS.REFL.FEM.ACC.SG
'He₁ loves his₁ (own) wife'
b. Hann elskar konu hans
He loves wife.ACC he.GEN
'He₁ loves his₂ (= somebody else's) wife'

In table 5.1, the inventory of Icelandic pronominal *possessives* is summarized.² Table 5.2 illustrates the inflection of *minn* (analogously, *þinn* and *sinn*), and table 5.3 gives an overview over the inflection of personal pronouns with an emphasis on the formal identity of the genitival forms and non-inflected *possessives*.

²NB: The honorific possessives *vor* 'our' (1.PL) and *ýðar* 'your' (2.PL) are largely restricted to solemn, formal language; *vor* is inflected like a strong adjective, see table 2.3 on page 51.

	SG		PL	
	<i>inflected</i>	<i>non-inflected</i>	<i>inflected</i>	<i>non-inflected</i>
1.	minn	---	vor	okkar
2.	þinn	---	---	ykkar / yðar
3.REFL	sinn	---	sinn	---
3.NON-REFL	---	hans MASC	---	þeirra
	---	hennar FEM	---	
	---	þess NEUT	---	

Table 5.1: *Pronominal Possessives: Inventory*

	SG			PL		
	MASC	FEM	NEUT	MASC	FEM	NEUT
NOM	minn	mín	mitt	mínir	mínar	mín
ACC	minn	mína	mitt	mína	mínar	mín
DAT	mínum	minni	mínu	mínum	mínum	mínum
GEN	míns	minnar	míns	minna	minna	minna

Table 5.2: *Inflected Pronominal Possessives: Inflection*

	'he'	'she'	'it'	'we'	'you' (pl)	they (m/f/n)
NOM	<i>hann</i>	<i>hún</i>	<i>það</i>	<i>við</i>	<i>þið</i>	<i>þeir/þær/þau</i>
ACC	hann	hana	það	okkur	ykkur	þá/þær/þau
DAT	honum	henni	því	okkur	ykkur	þeim
GEN (= <i>possessive</i>)	<i>hans</i>	<i>hennar</i>	<i>þess</i>	<i>okkar</i>	<i>ykkar</i>	<i>þeirra</i>

Table 5.3: *Personal Pronouns: Inflection – Non-Inflected Possessives*

The distinction between inflected and non-inflected *pronominal possessives* can be found in all Scandinavian languages. Cardinaletti (1998) proposes for Swedish that inflected *pronominal possessives* be analysed as “strong” and non-inflected ones as “deficient” (in the sense of Cardinaletti and Starke 1994, 1999). Tempting though it seems, there is no external syntactic motivation for such a disjoint analysis, not for the Mainland Scandinavian languages, nor for Icelandic. Inflected and non-inflected *pronominal possessives* have exactly the same distribution and the same possessive semantics. In the following, I will simply gloss the *possessives* as ‘my’, ‘her’, ‘their’ etc. (and POSS.REFL in the case of *sinn*) without specifying further whether they are inflected or not.

postnominal adjectives and numerals can equally well serve to identify the high position. In short, we have the following ordering involving POSS₁:

- (255) N (-DEF) >> POSS₁ >> NUM >> ADJ.WK >> ~~N~~
- a. drengir - nir mínir þrír elskuleg.u ~~drengir~~
 boys - DEF my three lovable.WK
- b. bræður hans þrír snjöll.u ~~bræður~~
 brothers his three clever.WK

The lower position POSS₂, on the other hand, is preceded by all numeral and adjectival modifiers in the order NUM ADJ N POSS. We find two patterns illustrating this constellation:

- (256) NUM >> ADJ.STR >> N >> POSS₂
- a. tveir snjall.ir bræður hans
 two clever.STR brothers his
- b. tvær elskuleg.ar dætur mínar
 two lovable.STR daughters my
- (257) ART >> NUM >> ADJ.WK >> N >> POSS₂
- a. hinir tveir snjöll.u bræður hans
 ART two clever.WK brothers his
- b. hinar þrjár fræg.u kenningar þínar
 ART three famous.WK theories your

According to the analysis developed so far, the moved nominal constituent simply labeled ‘N’ in (255) is *ixP*. Since *ixP* may contain adjectives that move along, yielding pattern (I), and since we furthermore have to take into account pattern (IV) modifiers that are merged outside *articleP* to begin with, prenominal adjectives are not as straightforward a diagnostic as postnominal ones when it comes to the position of the *pronominal possessive*. Here, numerals are more reliable, compare:

- (258) a. bækur - nar mínar þrjár fræg.u
 books - DEF my three famous.WK
 postnominal adjective: *possessive* unambiguously occupies POSS₁

stranded if either DEF is present, cf. (253d), or a *pronominal possessive* occupies the high position, cf. (254a) (or both, as in (253a)). In the former case, according to the analysis established in chapter 4, *ixP* moves to Spec-*articleP* stranding the *ixP*-external adjective, and I will argue that, in the latter case(s), the same happens, see sections 6.4.1 and 6.4.2.

The issue of presence vs. absence of DEF in *possessive constructions*, cf. (253a) vs. (254a), will be addressed in section 6.2.

- b. fræg.u bækur - nar mínar þrjár
 famous.WK books - DEF my three
 pronominal adjective: *possessive* occupies POSS₁; it precedes numeral
- c. þrjár fræg.ar bækur mínar
 three famous.STR books my
 pronominal adjective: *possessive* occupies POSS₂; it follows numeral

There is, on the other hand, a clear correlation between the position of the head noun/*ixP* and the position of *pronominal possessives*. If *ixP* is in its high position Spec-*articleP*, the *pronominal possessive* occurs likewise in the high position, i.e. POSS₁. Conversely, if the *pronominal possessive* occurs in the low position POSS₂, the head noun (*ixP*) occurs low, i.e. in its base position. In particular, *pronominal possessives* cannot occur in the low position POSS₂ if *ixP* is high:

(259) *N -DEF >> NUM >> A.WK >> ~~N~~ >> POSS₂

*drengir - nir þrír elskuleg.u ~~drengir~~ mínir cf. (255a)
 boys - DEF three lovable.WK my

(260) *N >> NUM >> A.WK >> ~~N~~ >> POSS₂

*bræður þrír snjöll.u ~~bræður~~ hans cf. (255b)
 brothers three clever.WK his

In other words, the presence of DEF, which indicates that *ixP* has moved to Spec-*articleP*, entails that an accompanying *pronominal possessive* occupies POSS₁ even with no modifier present as in (251a).⁴

Now it may seem tempting to interpret this correlation between the low and high positions of head noun and *pronominal possessive*, respectively, as an indication that there is movement from POSS₂ to POSS₁ which is somehow contingent on movement of *ixP* to Spec-*articleP*. There are indeed proposals in this vein; Vangsnes (1999b), for instance, assumes that head noun and *pronominal possessive* move together as elements of the same constituent. For a number of reasons discussed below, however, this is incompatible with some basic tenets of the analysis developed here. In addition, there are some empirical concerns suggesting that POSS₂ and POSS₁ cannot be related in this sense. First of all, note that, so far, I

⁴On the other hand, cases like (251b) where the head noun does not carry DEF - taken at face value - are ambiguous with respect to the position of the *pronominal possessive*; here the relative position of a modifier is still required to disambiguate:

- (1) a. bræður mínir þrír b. þrír bræður mínir
 brothers my three three brothers my
 ⇒ POSS₁ ⇒ POSS₂

have been exclusively concerned with postnominal *pronominal possessives*. Under certain conditions, however, *pronominal possessives* may occur prenominally, and their position relative to modifiers suggests that they occupy POSS₁. In other words, we have:

(261) POSS₁ >> NUM >> ADJ.WK >> N

þínar fjórar fræg.u kenningar (Sigurðsson 1993:181)
your four famous.WK theories

Note that the head noun (= *ixP*) must be assumed to occupy its low base position, thus the correlations stated above do not work the other way round: high position of the *pronominal possessive* (= POSS₁) does not entail high position of *ixP* (= *Spec-articleP*), and low position of *ixP* does not entail that the *pronominal possessive* occupies its low position (= POSS₂).

On the present analysis, the head noun cannot carry DEF in its base position (but must move to *Spec-articleP*), so we predict that a prenominal *pronominal possessive* occupying POSS₁ is incompatible with the sequence N-DEF. This is borne out:

- (262) a. i. *þínar (fjórar) (fræg.u) kenningar - nar
your four famous.WK theories - DEF
ii. *þínar (fjórar) kenningar - nar (fræg.u)
your four theories - DEF famous.WK
iii. *þínar kenningar - nar (fjórar) (fræg.u)
your theories - DEF four famous.WK
b. cf.: kenningar - nar þínar (fjórar) (fræg.u)
theories - DEF your four famous.WK

Now consider the following examples:

- (263) a. [... kapella ...] en nunnurnar sungu [...] í sínum hluta hennar
'... chapel₁ ... but the nuns₂ sang [...] in **their₂ part of it₁**'
<http://www.mbl.is/greinasafn/grein/60835/>
⇒ **sinn** hluti **hennar**
POSS.REFL part her NB: *kapella* 'chapel' is feminine
b. Náist samningur er afar mikilvægt að þú standir við þinn hluta hans
'If an agreement₁ is reached, it is very important that you stand by **your part of it₁**'
http://www.ums.is/media/umbodsmadur-skuldara/UMS_baeklingur_Net.pdf
⇒ **þinn** hluti **hans**
your part his NB: *samningur* 'agreement, contract' is masculine

Admittedly, the number of head nouns that allow two *pronominal possessives* simultaneously is very small. Crucially, the pattern exists, and thus, evidently, there are two slots that can be independently filled. In other words, we cannot simply assume that the (pre)nominal *pronominal possessives* in examples like (263), which I take to occupy POSS_1 , start out from the lower position POSS_2 .

As a modified alternative, we could imagine some merely optional movement operation along the lines: if POSS_1 is not occupied, a *pronominal possessive* may move there from POSS_2 . But even that version faces serious challenges. Examples like the ones under consideration clearly show that the semantic contribution of *pronominal possessives* differs considerably depending on whether they occupy POSS_1 or POSS_2 . Amongst other things, the *pronominal possessives* occurring postnominally in (263) cannot occur prenominally with the same reading:

- (264) hans hluti
 his part
 \Rightarrow ^{ok}‘his part (of sth)’
 \Rightarrow #‘part of it’; cf. (263b)

The fact that both POSS_1 and POSS_2 can be occupied simultaneously, and the semantic contrast indicated in (264), in conjunction with my assumption that POSS_2 is a phrasal position, whereas POSS_1 is a head position, strongly suggests that the two positions are not derivationally related.

Thus summarizing this subsection, I have argued that *pronominal possessives* may occur in a low position POSS_2 surfacing postnominally only, and a high position POSS_1 surfacing either postnominally or prenominally. The ordering relative to modifiers and head noun can abstractly be represented as follows:

- (265) N (-DEF) >> **POSS**₁ >> NUM >> ADJ >> N >> **POSS**₂

5.2.3 The Position of DP-Genitives

DP-genitives can only occur postnominally:⁵

- (266) a. bræður Jóns
 brothers Jón.GEN
 b. bræður kennarans
 brothers teacher.the.GEN

⁵If the genitival noun carries the suffixed article, it will be glossed as “.the.” (rather than -DEF), cf. (266b). In case the *DP-genitive* is complex, I will put the corresponding gloss in square brackets and mark genitive case only once, cf. (266c). This is merely for the sake of convenience and should not gloss over the fact that (genitive) case is morphologically marked not only on the noun, but also on determiners, numerals and adjectives (inconvenient version: “ART.GEN great.GEN genius.GEN).

- c. bræður hins mikla snillings
brothers [ART great genius]-GEN

By the same token as in the previous subsection, their position relative to numeral and adjectival modifiers indicates that they occupy the low position $POSS_2$:⁶

- (267) a. NUM >> A.STR >> N >> $POSS_2$
þrír snjall.ir bræður Jóns
three clever.STR brothers Jón.GEN
b. ART >> NUM >> A.WK >> N >> $POSS_2$
hinir þrír snjöll.u bræður Jóns
ART three clever.WK brothers Jón.GEN

Unlike *pronominal possessives*, they cannot occur in $POSS_1$. This is evidenced by the fact that they can never precede numeral or adjectival modifiers:

- (268) *N >> $POSS_1$ >> NUM >> A.WK >> N
a. *bræður Jóns þrír (cf. ^{ok}bræður hennar þrír)
brothers Jón.GEN three brothers her three
b. *bræður Jóns snjöll.u (cf. ^{ok}bræður mínir snjöll.u)
brothers Jón.GEN clever.WK brothers my clever.WK

Normally, with *DP-genitives*, the head noun also occurs in its low base position. However, in certain cases (see section 6.3), the head noun, i.e. *ixP*, may occur in its high position (*Spec-articleP*) as evidenced by the presence of DEF. But even in these cases, numeral and adjectival modifiers that surface postnominally precede the *DP-genitive* reiterating the point that the latter exclusively occur in $POSS_2$:

- (269) N - DEF >> NUM >> A.WK >> $POSS_2$
a. hestur - inn frægi hans afa
horse - DEF famous [he grandfather]-GEN
(<http://siggisturlu.blog.is/blog/siggisturlu/day/2006/11/11/>)
b. Palestínuljóð - ið fræga Kristjáns frá Djúpalæk (MÍM)
Palestine-song - DEF famous Kristján.GEN from Djúpalækur
c. bækur - nar fjórir hans Péturs (Vangsnes 2004)
books - DEF four [he Pétur]-GEN
d. ^{??}myndir - nar þrjár frægu Astridar af Dorian Gray (Harðarson 2014a)
pictures - DEF three famous Astrid.GEN of Dorian Gray

Note that, with a *DP-genitive* in $POSS_2$, *ixP* can only occur in its high position iff DEF is present (see also (259)/(260)):

⁶Incidentally, examples like (266c) clearly illustrate that *DP-genitives* are phrasal, and thus that $POSS_2$ is an XP position.

- (270) *bækur fjórir ~~bækur~~ hans Péturs cf. (269c)
 books four [he Pétur]-GEN

It is, however, crucial to briefly address one aspect that, at first glance, appears to contradict the point just made, namely the fact that we also find non-pronominal GENITIVALS in prenominal position:

- (271) Jóns bók
 Jón.GEN book

According to the ordering criterion, they must be assumed to occupy POSS₁:

- (272) **POSS₁** >> NUM >> ADJ.WK >> N
 Astridar þrjár fræg.u myndir af Dorian Gray (Harðarson 2014a)
 Astrid.GEN three famous.WK pictures of Dorian Gray

The prenominal position is, however, highly restricted for non-pronominal GENITIVALS, and judgments vary across speakers and individual cases:

- (273) a. Sigga hjól (Magnússon 1984:101/2)
 Siggi.GEN bike
 b. ?kennarans bíll
 teacher.the.GEN car
 c. *Ríkisstjórnarinnar ákvörðun
 national-government.the.GEN decision
- (274) a. *málfræðingsins fyrirlestur (Sigurðsson 1993:188/9)
 linguist.the.GEN lecture
 b. *Péturs fyrirlestur
 Peter's lecture
- (275) a. Péturs fyrirlestur (according to Thráinsson 2007:93/4; fn. 5)
 Peter's lecture
 b. ?stelpunnar bók
 girl.the.GEN book
 c. ??málfræðingsins fyrirlestur
 linguist.the.GEN lecture

Based on (273)-(275), the only fairly discernible tendency towards a morpho-syntactic generalization is that proper names fare somewhat better than definite common nouns (i.e. N.the.GEN) as prenominal GENITIVALS. There is, however, a stronger contrast that that seems to highlight the actual issue. (Magnússon 1984:102) observes that a prenominal *DP-genitive* can “never be more than one word”:

- (276) a. * leiðinlega kennarans bók (Magnússon 1984:101)
 [boring teacher.the]-GEN book
 b. * Sigga frænda hjól (Magnússon 1984:102)
 [Siggi uncle]-GEN bike
- (277) a. * leikarans fræga bíll c. * þessarar stelpu bók
 [actor.the famous]-GEN book [this girl]-GEN book
 b. * hans Jóns bók d. * hins fræga leikara bók
 [he Jón]-GEN book [ART famous actor]-GEN book

Put slightly differently, these examples strongly suggest that prenominal GENITIVALS cannot be phrasal, regardless of whether the nouns involved are otherwise acceptable as one-word units in the same constellation (for instance (273a) vs. (276b)). The stark contrast between examples (273) through (275), which allow some speaker variation in acceptability, and examples (276)/(277), which are categorically bad, is striking. The restriction in the latter case appears to be strictly morpho-syntactic in nature.⁷ I will immediately return to this issue in the next subsection.

In this subsection, I have shown that *DP-genitives* always occur in the low position POSS₂, which is a position for XPs:

- (278) N -DEF >> NUM >> ADJ >> N >> POSS₂

Notably, *DP-genitives* occur in the low position even though the head noun constituent (i.e. *ixP*) may occur in its high position. Apparent cases of non-pronominal GENITIVALS in POSS₁ can be shown not to actually involve *DP-genitives* insofar as DPs (XPs) are not licit in this position.

5.2.4 POSS₁ Revisited

On the view that POSS₁ is an X⁰ position, we have a straightforward account of the facts presented in the previous two subsections. This idea was a crucial element of Delsing's (1993, 1998) analysis who argued that *pronominal possessives* at large are merged as heads in POSS⁰. More differentiated analyses argue the point that some *pronominal possessives* (subject to cross-linguistic and language-internal variation) are (clitic) heads that have determiner-like properties and carry

⁷A constraint of this kind is hard to account for on the widespread assumption that prenominal GENITIVALS occupy some specifier position in the nominal left periphery and thus are XPs. This assumption can account for Saxon Genitives in English and the corresponding construction in Mainland Scandinavian, and dative possessors in Hungarian, but evidently, not for prenominal GENITIVALS in Icelandic.

a definiteness feature (for instance Schoorlemmer 1998; Ihsane 2000, 2003; Cardinaletti 1998).

Based on this set of assumptions, I propose an Icelandic-specific implementation: only POSS^0 (= POSS_1) can be overtly lexicalized, but not, say, Spec-POSSP (which is presumably occupied by some *pro*). Therefore we do not find (clearly) phrasal GENITIVALS in prenominal position (and by extension, in POSS_1). *Pronominal possessives* can easily spell out this head position. Non-pronominal GENITIVALS can spell out POSS_1 as we have seen, but I submit that they are actually parsed as heads. A construal as heads may explain why it is easier for proper names to occur in POSS_1 than it is for common nouns + DEF (different degrees of morphological complexity). Bottom line for this categorial coercion is that they be one-word units.

In section 6.1, we will furthermore see that GENITIVALS in POSS_1 seem to trigger weak inflection on adjectives and make the noun phrase definite (even in the absence of DEF), which corroborates the idea that they have themselves determiner-like properties. In addition, we will see that *possessors* in POSS_1 must be [+HUMAN] and cannot be thematic arguments (see sections 6.2, 6.4.1, 6.4.2).

Given all these observations and the conclusions they seem to suggest, the following structure for POSS_1 emerges:

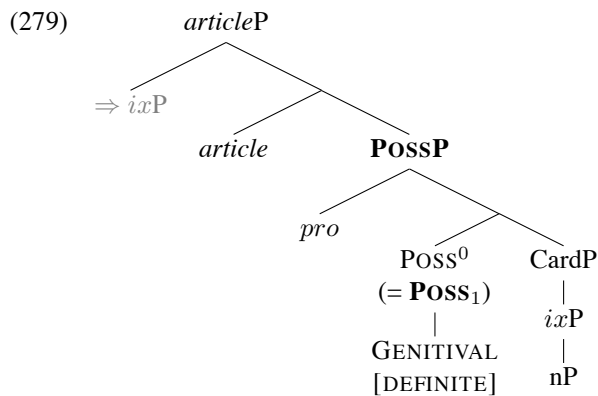

As for the low position POSS_2 , I will follow Delsing (see next section) to the extent that I propose that it is a complement position somewhere inside *ixP*. It will turn out, however, that it cannot simply be the complement position of N (as Delsing proposes). There are various empirical problems posed by the Icelandic data (such as postnominal modifiers and the stranding of *DP-genitives*) that rule out that structural option. Instead I propose a novel architecture of the (lower part of the) noun phrase, for which purpose, I will heavily draw on Adger (2013). I will postpone a discussion of the theoretical and technical details concerning POSS_2 to

section 7.2.

5.3 Previous Analyses

In this section, I will briefly discuss relevant aspects of some previous formal treatments of Icelandic (Scandinavian) GENITIVALS. The purpose is not so much to give an in-depth description of them, but rather to show where they crucially deviate from the present proposal.

Many approaches to the Scandinavian noun phrase construe GENITIVALS as specifiers merged in a nominal specifier position (Spec-NP or Spec-nP) below adjectives (for instance Sigurðsson 1993; Vangsnes 1999b; Julien 2002, 2003, 2005a,b). Thus one way or another, they all incorporate the following structure:

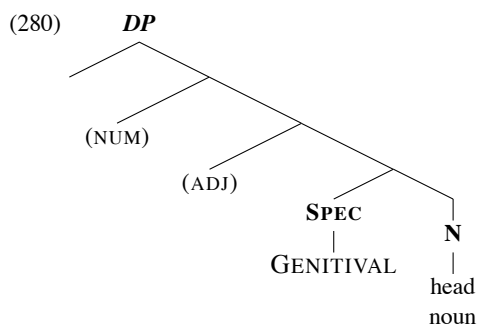

Vangsnes (2004), on the other hand, assumes that GENITIVALS are merged within nP⁸ immediately above the projection hosting adjectives, but below numerals:

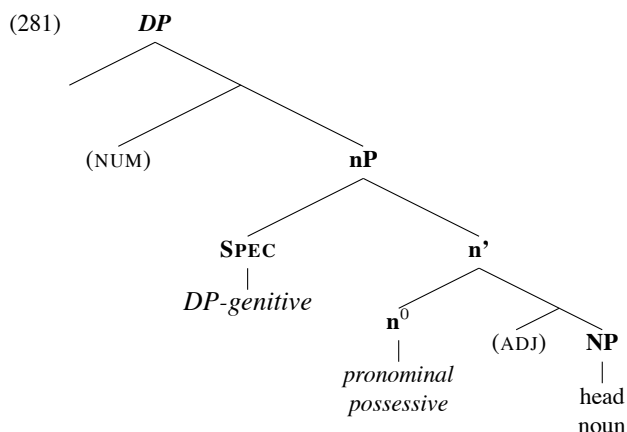

⁸More precisely, he distinguishes between pronominal and non-pronominal GENITIVALS; the former are merged as clitic heads in n⁰, whereas the latter are specifiers generated in Spec-nP.

Sigurðsson (2006) gives a descriptive and rather theory-neutral account of the Icelandic noun phrase according to which both pronominal and non-pronominal GENITIVALS are merged in a position **G**(enitive)⁹ which is located below numerals, but above adjectives. In table 5.4, his analysis of the following examples is illustrated:

- (282) a. bílar - nir þínir þrír cars - DEF your three
 b. þín bók your book
 c. þessir þrír bílar þínir these three cars your
 d. bílar - nir hans Jóns cars - DEF [he Jón]-GEN

	Spec/D	D	Num	Spec/G	G	(Adj+) Noun
a.)	bílar _i -nir	þínir _k	þrír	---	← _k	← _i
b.)	---	ÞÍN _k	---	bók _i	← _k	← _i
c.)	---	þessir	þrír	bílar _i	þínir	← _i
d.)	bílar _i -nir	---	---	---	hans Jóns	← _i

Table 5.4: (taken from Sigurðsson 2006:214/5, tables 5 and 8)

Disregarding the technicalities, Vangsnes (2004) and Sigurðsson (2006) have in common that GENITIVALS are assumed to be generated between adjectives and numerals. Yet another alternative is presented by Delsing (1993, 1998) who proposes that *pronominal possessives* are merged as heads in POSS⁰ (~ POSS₁), whereas *DP-genitives* are complements to N (just like possessive and complement PPs). His proposed structure is this (Delsing 1993:167; 1998:104):

⁹The phrase-structural status of this position G is not entirely clear to me. The fact that Sigurðsson assumes a position Spec-G, which is used as an (intermediate) landing site for nouns, cf. examples b.) and c.) in table 5.4, suggests that G itself is a head position. So does the fact that *pronominal possessives* are assumed to move from G to D⁰, cf. examples a.) and b.). On the other hand, this conclusion is at odds with G hosting clearly phrasal constituents such as *DP-genitives* involving a pronominal article as in d.) (to be discussed in more detail below).

Another unclarity (for me) is the status of the suffixed article: as on the present account, Sigurðsson assumes some constituent containing N to move to the high specifier position Spec-DP (~ Spec-articleP), but on his account, this is also the position where the suffixed article is generated. This seems to suggest that NP moves into a constituent already containing DEF. Sigurðsson motivates this on grounds that *pronominal possessives* move to the D⁰ position on his analysis; since (postnominal) *pronominal possessives* and DEF co-occur, cf. example a.), DEF must be located even higher.

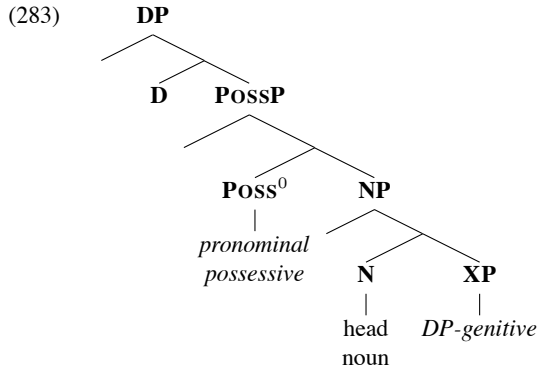

Delsing does not explicitly state that *pronominal possessives* are merged above numerals, but this follows straightforwardly from his following assumptions: (i) “POSS may select DP, DegP, AP or NP” (Delsing 1993:167), and (ii) numerals “are adjectives or degree elements” (op.cit.:102).

With this in place, we can distinguish three groups of analyses according to their assumed merge position of GENITIVALS relative to modifiers and the head noun:

- (284) a. NUM >> ADJ >> GENITIVAL >> N cf. (280)
 b. NUM >> GENITIVAL >> ADJ >> N cf. (281), table 5.4
 c. X⁰-GENITIVAL >> NUM >> ADJ >> N >> XP-GENITIVAL cf. (283)

Architecturally, (284c), comes closest to the present analysis, but as we will see shortly, there are some specific details where the two analyses differ. Analyses that fall into the other two groups (284a) and (284b) are categorically irreconcilable with empirical criteria, analytical decisions and theoretical assumptions of the present proposal.

First of all, the alleged base orderings as represented in (284a) and (284b) never surface. That is, we do not find GENITIVALS surfacing between adjective (or numeral) and head noun, nor GENITIVALS that surface between numerals (or adjectives) and adjectives.¹⁰ In order to derive the various attested surface patterns

¹⁰Note that the following example is not a counterexample:

- (1) margar/ fimm **mínar** frægu bækur
 many/ five my famous books
 ‘many/five of my famous books’

On my account, the elements preceding the *pronominal possessive* are, in fact, *little partitives*, i.e. pattern (IV) modifiers, which are merged outside *articleP* to begin with; see section 3.3.2.

of *possessive constructions*, these analyses rely more or less extensively on WOMs like roll-up operations or remnant movement. In particular, they must systematically assume movement of N across the GENITIVAL in order to account for the default postnominal position of GENITIVALS – both pronominal and non-pronominal ones, for both POSS₁ and POSS₂. The present account dispenses with such operations. Instead, I attempt to show that all observed (linear) orders are the result of base generation and one criterial movement, viz. *iXP-to-Spec-articleP* (or the absence thereof), which I have argued for on independent grounds. This entails, especially, that GENITIVALS cannot be merged between (*iXP*-internal) adjectives and N.

In the following, I will briefly illustrate some problems of the above proposals. Let us have a look at the following examples involving both *pronominal possessives* and numerals (Vangnes 1999b:145; emphasis mine):

- (285) a. frægu bækur - nar mínar þrjár
famous books - DEF my three
b. hinar þrjár frægu bækur mínar
ART three famous books my
c. *frægu bækur - nar þrjár mínar
famous books - DEF three my

According to ordering criteria discussed above, the *pronominal possessive* occupies POSS₁ in (285a), but POSS₂ in (285b). Delsing (1993, 1998) does not explicitly address this issue, but the noun phrase structure that he proposes allows for a quite simple treatment of examples like (285a) while capturing the ungrammaticality of (285c). The sequence POSS >> NUM is base generated. The A + N constituent, on the other hand, must be assumed to move to Spec-DP (which corresponds to *iXP-to-Spec-articleP* in my account):¹¹

- (286) a. $[_{DP} \text{ } [_{D'} D^0 [_{PossP} \text{ } [_{Poss'} POSS^0 [_{YP} Num [_{AP} A^0 [_{NP} N (XP)]]]]]]]]$
b. $[_{DP} [\text{frægu bækur}]_k [_{D'} \text{-nar} [_{PossP} [_{Poss'} \text{mínar} [_{CardP} \text{þrjár } t_k]]]]]]$

So, glossing over details, Delsing's account of *pronominal possessives* is largely identical to my treatment of POSS₁. However, it cannot handle POSS₂ as in (285b)

¹¹Things are more complicated, and there are some issues that I will ignore. For instance, as the following example illustrates, Delsing actually assumes that that postnominal *pronominal possessives* head-move to D, and moreover, that N-DEF is already a unit prior to movement to Spec-DP:

- (1) a. hus - et hans Per (Delsing 1998:101)
house - the his Per
b. $[_{DP} \text{huset}_k [_{D'} \text{hans}_i [_{PossP} \text{Per}_j [_{Poss'} t_i [_{NP} t_k t_j]]]]]]$ (Delsing 1998:103)

The latter assumption is strictly incompatible with my analysis of DEF in Icelandic, but for the case in point this is a minor issue. Thus (286b) is a slightly modified version of Delsing's actual proposal.

without serious stipulations or modifications. First of all, on this account, *pronominal possessives* are categorically construed as heads in POSS^0 , which means that they cannot be assumed to occupy the lower position complement-to-N (= XP). Thus in order to derive the correct surface order, with the *pronominal possessive* postnominal, we must assume that the entire constituent comprising numeral, adjective and noun moves across POSS^0 . If that constituent moves to Spec-DP as in (286b), we would furthermore have to assume DP-recursion, cf. (287a), or alternatively, movement of the article to a higher position, cf. (287b), in order to ensure that ART precedes the nominal. Another option would be to assume that that constituent exceptionally moves to Spec-POSSP, cf. (287c):¹²

- (287) a. $[_{DP_2} \text{hinar} [_{DP_1} [\text{þrjár frægu bækur}]_k [_{D'_1} \text{mínar}_j [_{POSSP} [_{POSS'} t_j t_k]]]]]$
 b. $[_{XP} \text{hinar}_j [_{DP} [\text{þrjár frægu bækur}]_k [_{D'} t_j [_{POSSP} [_{POSS'} \text{mínar} t_k]]]]]$
 c. $[_{DP} \text{hinar} [_{POSSP} [\text{þrjár frægu bækur}]_k [_{POSS'} \text{mínar} t_k]]]$

Ignoring the concrete problem of which of these options can be best motivated, Delsing's analysis essentially entails that, when it comes to *pronominal possessives*, POSS_1 is identical to POSS_2 , i.e. that there is only a high merge position for *pronominal possessives*. This is an undesirable result for a variety of reasons, most notably, because of examples like (263) that illustrate that pre- and postnominal *pronominal possessives* can co-occur, i.e. simultaneously occupy POSS_1 and POSS_2 , respectively.

According to Sigurðsson's (2006) framework, examples (285a/b) are expected to receive the following analyses:

	Spec/D	D	NUM	Spec/G	G	ADJ+N
a.)	frægu bækur _i -nar	mínar _k	þrjár	- - -	← _k	← _i
b.)	- - -	hinar	þrjár	frægu bækur _i	mínar	← _i

Table 5.5: "my three famous books" according to Sigurðsson 2006

As indicated by the index k in the a-example, this analysis operates with two assumptions in particular: (i) there is a high position D and a low position G for *pronominal possessives*, and (ii) they are derivationally related by G-to-D movement. Prima facie, point (i) seems compatible with my proposal of there being two positions, POSS_1 and POSS_2 , but I do argue against (ii) (see above). As already mentioned (see fn. 9), Sigurðsson's position G appears to be phrasal in nature – which is also my take on POSS_2 , but precisely this is one of the reasons why I

¹²Yet option (287c) is incompatible with Delsing's own assumptions that Spec-POSSP is the (intermediate) landing site for certain possessor phrases, whereas the constituent containing the head noun normally moves to Spec-DP (cf. *Per* and *huset* in example (1b) in fn. 11).

reject a derivational relationship between the XP position $POSS_2$ and the X^0 position $POSS_1$, and precisely this makes the operation G-to-D movement suspect. Also recall from example (264) that there are semantic objections against $POSS_2$ -to- $POSS_1$.¹³

On Vangsnes' (1999) account, GENITIVALS are generated even lower, namely below adjectives. But there are some further aspects that set this analysis apart from both Sigurðsson (2006) and Delsing (1993, 1998). First of all, "the suffixed article in Icelandic is merged with the noun in the lexicon [...] and [...] is not generated in the head position of a functional projection" (op.cit.:145), in other words, he assumes a low position for DEF. *Pronominal possessives* are generated as XPs in Spec-NP. On top of NP, there is a projection DxP ; N^0 (i.e. N-DEF) raises and adjoins to Dx^0 rendering the possessive postnominal. Spec- DxP is the position where ART and demonstratives are generated. This particular aspect is inspired by the idea of demonstratives being generated in a low position below adjectives (cf. Brugé 1996). Numerals and adjectives are merged as heads in the extended nominal projection above DxP , with numerals adjoined to a functional head ν . His analysis of (285a/b) is given below:

(288) a.

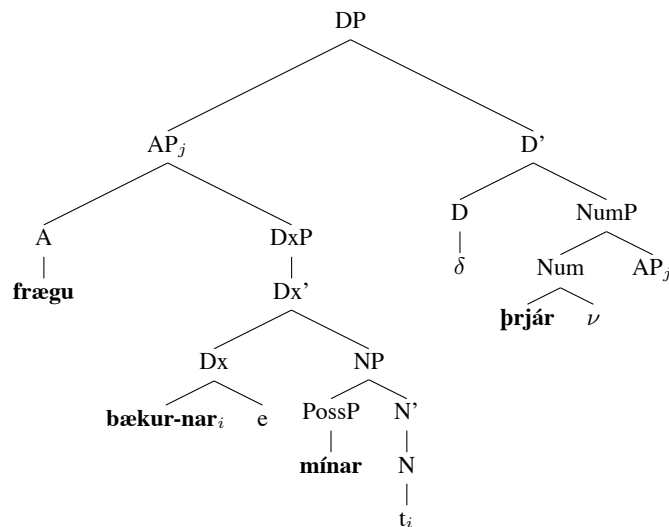

¹³Moreover, there arises an issue concerning base ordering. On Sigurðsson's account, GENITIVALS are merged between numerals and adjectives. Thus he will have to postulate a second position for adjectives between Num and G in order to account for examples like the following:

- (1) hestar - nir tveir **frægu** hans afa
 horses - DEF two famous [he grandfather]-GEN

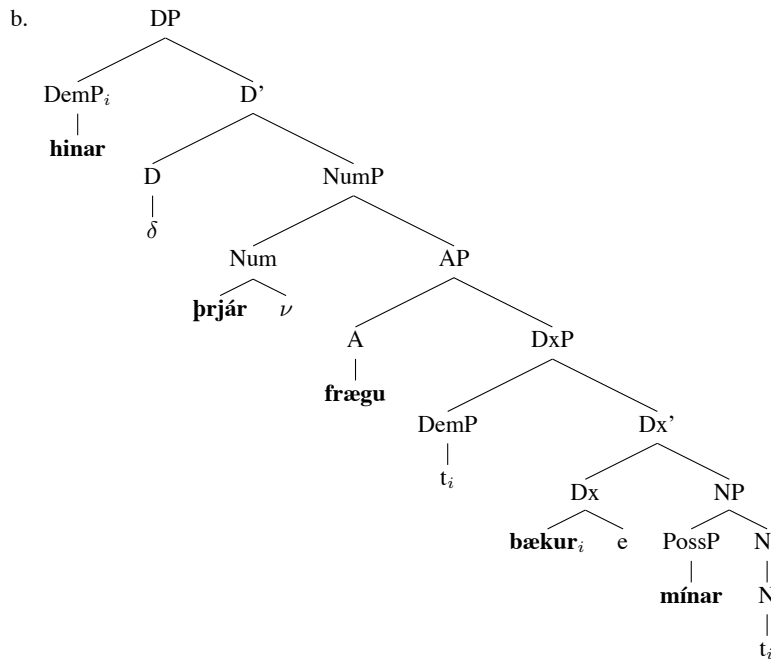

The account given in Vangsnes (2004) is slightly different from the one just outlined; the derivation of (285a) is summarized below:

(289) D^0 [$_{CardP}$ þrjár [$_{nP}$ mínar [$_{\alpha P}$ frægu [$_{AnaP}$ -nar [$_{WP}$ -ur [$_{NP}$ bæk-
(Vangsnes 2004:7)

- a. [[[bæk]₁-ur t₁]₂-nar t₂]
- b. [$_{\alpha P}$ frægu [[[bæk]₁-ur t₁]₂-nar t₂]]
- c. [$_{nP}$ mínar [$_{\alpha P}$ frægu [[[bæk]₁-ur t₁]₂-nar t₂]]]]
- d. [$_{nP}$ [$_{\alpha P}$ frægu [[[bæk]₁-ur t₁]₂-nar t₂]]]₃ mínar t₃]]
- e. [$_{CardP}$ þrjár [$_{nP}$ [$_{\alpha P}$ frægu [[[bæk]₁-ur t₁]₂-nar t₂]]]₃ mínar t₃]]
- f. [$_{DP}$ [$_{nP}$ [$_{\alpha P}$ frægu [[[bæk]₁-ur t₁]₂-nar t₂]]]₃ mínar t₃]₄ D^0 [$_{CardP}$ þrjár t₄]]

Here the plural marker is assumed to head a projection WP above NP, and DEF a projection AnaP above WP, so *bækurnar* ‘book-s-DEF’ is the result of consecutive head movement and head adjunction, (289a). Both analyses require the head noun to move across the *pronominal possessive* stranding the latter in postnominal position the difference being that Vangsnes (1999b) assumes head movement (N⁰-to-Dx⁰), while Vangsnes (2004) assumes phrasal (α P) movement, cf. (289d). This difference correlates with the different merge positions of GENITIVALS, below adjectives in the former account, but between numerals and adjectives in the latter.

Like Sigurðsson (2006), Vangsnes (1999b, 2004) thus distinguishes a derived high position where the *pronominal possessive* precedes the numeral and a low base position (G – Spec-NP/n⁰) where it follows the numeral, cf. (288a) vs. (288b), and (289c-e) vs. (289f). But there is a crucial difference: Sigurðsson’s G-to-D movement of *pronominal possessives* is an independent operation, while, on Vangsnes’ account(s), movement of *pronominal possessives* is contingent upon movement of the head noun. More precisely, Vangsnes’ decisive move in analysing examples like (285a) is his construing the sequence A N-DEF POSS (*frægu bækur-nar mínar* ‘famous books-DEF my’) as one constituent to the exclusion of the numeral, that is, a constituent that may move across the numeral, cf. (288a)/(289f).

While this kind of analysis may be rather appealing for a number of reasons, it comes at a dear price: it requires DEF to be generated rather low, namely below *pronominal possessives*, and even below adjectives. This is at odds with the centerpiece of the analysis developed here. I have argued at length that the suffixed article is merged in a high position *article*⁰ above numerals, and this is the condition sine qua non of this thesis. This assumption has allowed us to derive all patterns of adjectival and numeral modification, and in particular, given a straightforward account of stranded modifiers and mixed patterns. We will see that the addition of POSS₁ as a base position for *pronominal possessives* as sketched in (279) allows us to account for a large portion of the new data involving *pronominal possessives* while retaining the results of the previous chapters.

In other words, the difference in terms of base position of DEF is rather detrimental, and makes Vangsnes’ account(s) a priori incompatible with the present approach. More so, given certain non-negotiable assumptions like ‘DEF is base-generated in *article*⁰’ and ‘*ixP*-internal adjectives form a narrow constituent with the head noun’, it iterates and highlights the point that I cannot derive POSS₁ from POSS₂, nor assume that POSS₂ is a low specifier position (Spec-NP or Spec-nP) in deriving the attested surface orderings (i.e. adjectival patterns) without relying excessively on vacating movement with subsequent roll-up operations or arbitrary word order movement. Nor can I assume that head noun and *pronominal possessive* occurring in POSS₁ form a constituent to the exclusion of the numeral.

Chapter 6

Possession and Definiteness Marking

In this chapter, I will examine the marking of definiteness in *possessive constructions*, and scrutinize some syntactic and semantic ramifications. I will have a look at both definiteness marking on adjectives (\sim weak inflection) and on the head noun (\rightarrow -DEF) – or the absence thereof. I will show that POSS_1 and POSS_2 have a different impact on the overall definiteness of the noun phrase. I will further examine the different distribution of *DP-genitives* and *pronominal possessives* with respect to DEF, and to what extent the presence or absence of DEF has an impact on the possessive relation expressed by the *possessive construction*.

6.1 Possession and Adjectival Inflection

I argued in chapter 2 that weak inflection on adjectives is triggered/licensed (prior to movement) by a c-commanding [DEFINITE] feature which is typically provided by the article morpheme. If this requirement is not met for any reason – either [DEFINITE] is not present altogether (as in indefinite noun phrases), or it does not c-command the adjective because the adjective is merged higher in the structure (e.g. “outside” *articleP*) – the adjective inflects strongly. This assumption has been sufficient to account for the distribution of adjectival inflection in the four patterns discussed in chapters 3 and 4. As a matter of fact, we find all four patterns also in *possessive constructions*:

- (290) a. *Pattern (I) + Pronominal Possessive*
ný.i bíll - inn hans
new.WK car - DEF his

- b. *Pattern (II) + Pronominal Possessive*
 hin umdeild.a kenning hans
 ART controversial.WK theory his
- c. *Pattern (III) + Pronominal Possessive*
 hestur - inn hans fræg.i
 horse - DEF his famous.WK
- d. *Pattern (IV) + Pronominal Possessive*
 i. blaut. föt - in hennar
 wet.STR clothes - DEF her
 ii. í miðj.u herbegi - nu mínu
 in middle.STR room - DEF my
- (291) a. *Pattern (I) + DP-genitive*
 ný.i bíll - inn hans pabba
 new.WK car - DEF [he dad]-GEN
- b. *Pattern (II) + DP-genitive*
 hin umdeild.a mynd Hrafns Gunnlaugssonar
 ART controversial.WK film [Hrafn Gunnlaugsson]-GEN
- c. *Pattern (III) + DP-genitive*
 hestur - inn frægi hans afa
 horse - DEF famous [he grandfather]-GEN
- d. *Pattern (IV) + DP-genitive*
 aut.t rúm - ið hennar fóstru
 empty.STR bed - DEF [she foster-mother]-GEN

Apart from noting the fact as such, nothing more needs to be said about the distribution of adjectival inflection that does not already follow from the account given in the previous chapters. Weak inflection in patterns (I)-(III), (290a-c)/(291a-c), is triggered by [DEFINITE] on the article which c-commands the (*articleP*-internal) adjective in its base position, prior to *ixP* movement in the case of pattern (I). The weak inflection is not triggered, which results in the default strong inflection, in (290d)/(291d) because, as I argue, pattern (IV) modifiers are merged outside *articleP* altogether, and thus outside the c-command domain of [DEFINITE].

Data like these do not allow any conclusion about whether the GENITIVAL has any impact on adjectival inflection. Therefore it is most revealing to have look at (adjectivally modified) *possessive constructions* that do not involve -DEF. First of all, we find that adjectives in a “post-GENITIVAL” position are necessarily weakly inflected, regardless of whether the GENITIVAL occurs prenominal or postnominally. According to the criteria given in section 5.2.2, GENITIVALS preceding other modifiers occupy the high position $POSS_1$:

- (292) a. þín hetjuleg.a (*hetjuleg.) barátta
 your heroic.WK —.STR battle
- b. Íslands fögr.u (*fögur.) fjöll (Sigurðsson 2006:15)
 Iceland.GEN beautiful.WK —.STR mountains
- c. minn meint.i alvarleg.i (*meint.ur alvarleg.ur) geðsjúkdómur
 my alleged.WK serious.WK —.STR —.STR mental-illness
<https://www.facebook.com/rotin.felag/posts/537485866333154>
- (293) a. tengdforeldrar mínir væntanleg.u (*væntanleg.ir)
 parents-in-law my expected.WK —.STR
- b. systir mín elskuleg.a (*elskuleg.)
 sister my lovable.WK —.STR
- c. afi minn sálug.i (*sálug.ur)
 grandfather my deceased.WK —.STR

Since GENITIVALS in POSS₁ c-command *article*P-internal adjectives, the fact that the respective adjectives are weakly inflected is straightforwardly accounted for if the GENITIVALS themselves carry a feature [DEFINITE]. I put a special emphasis on the position POSS₁, for only GENITIVALS occurring in that position make the noun phrase formally definite (see below); only they systematically trigger the weak inflection on (*article*P-internal) adjectives. I will show below that this is not so for GENITIVALS occurring in POSS₂. But first I will elaborate on some empirical aspects:

- (294) a. hin elskuleg.a systir mín
 ART lovable.WK sister my
- b. elskuleg. systir mín
 lovable.STR sister my
- c. ?elskuleg.a systir mín
 lovable.WK sister my
 ‘my lovable sister’

The weak inflection on the adjective in (294a) is triggered by ART, as expected. In (294b), there is no article, i.e. no element carrying [DEFINITE] that c-commands the adjective, and thus, as predicted, the adjective shows up strongly inflected. (294c), however, which appears to be rather similar to (294b), is unexpected and seems to violate the generalization just confirmed: we have a bare weak adjective.¹

¹The question mark in (294c) is meant to indicate that some of my informants considered the example deviant, or at least, less good than (294b), notably, when used as an argumental noun phrase. But (294c) is fully acceptable for vocative noun phrases, see section 2.2.1. Nonetheless, the pattern is attested, and many (especially younger) speakers do find it fully acceptable.

Weak inflection is also typically found with adjectives that are part of fixed expressions:

I will argue that there is a subtle difference between (294b) and (294c) and propose the following: the *pronominal possessive* in (294a/b) occupies POSS₂ whence it has no impact on the adjectival inflection. If a definite morpheme is present in a c-commanding position, the adjective is weakly inflected, cf. (294a), if not, it is strongly inflected, cf. (294b). In (294c), on the other hand, the *pronominal possessive* is merged in POSS₁ whence it does c-command the adjective and thus trigger the weak inflection. This way, the derivation of such examples can be shown to closely mimic the structural relationship and derivations of patterns (II)-(III)-(I) with the *pronominal possessive* occupying a fixed position across which *ixP*, possibly containing an adjective, can move. A crucial aspect is that (weak) adjectival inflection is determined before (*ixP*) movement takes place, cf. (295c):

- (295) a. **mín** elskuleg.a systir
my lovable.WK sister
- b. systir **mín** elskuleg.a ~~systir~~
sister my lovable.WK
- c. elskuleg.a systir **mín** ~~elskuleg.a~~ ~~systir~~
lovable.WK sister my

In section 5.2.2, I pointed out that the relative position of numerals, postnominal adjectives, and the presence of -DEF are unambiguous diagnostics for the position of *pronominal possessives* (and, as a matter of fact, for the position of *ixP*), whereas prenominal adjectives are not as reliable. So in order to show that the *pronominal possessive* in (294c) really is in the high position POSS₁, and conversely, that the one in (294b) really is in POSS₂, we need to add at least a numeral; compare the following contrasts:

- (296) NUM >> A.STR >> *ixP* >> POSS₂
- a. i. **þrír** snjall.ir bræður **hans**
three clever.STR brothers his
- ii. ***þrír** snjöll.u bræður **hans**
three clever.WK brothers his
- b. *ixP* >> POSS₁ >> A.WK >> NUM
- i. ^{ok?}snjöll.u bræður **hans þrír**
clever.WK brothers his three
- ii. *[?]snjall.ir bræður **hans þrír**
clever.STR brothers his three

(1) a. litl.i bróðir (minn)
little.WK brother (my)

b. stóra systir (mín)
big.WK sister (my)

I will ignore these aspects and show that examples like (294c), actually, do not constitute a counterexample to my generalization.

Example (296a) illustrates that, if *ixP* is demonstrably in its low position, as evidenced by the numeral preceding the whole lot, and the *pronominal possessive* thus unambiguously occupies the low position POSS₂, the adjective must be strongly inflected. On the other hand, if the *pronominal possessive* unambiguously occupies the high position POSS₁, as evidenced by its preceding the numeral, cf. (296b), *ixP* must have moved across it from a c-commanded position, and the adjective contained in *ixP* is weakly inflected, as predicted.²

In other words, GENITIVALS in POSS₁ systematically trigger weak inflection on *articleP*-internal adjectives, even in the absence of a definite determiner, and regardless of whether *ixP* moves or stays put. This, in turn, corroborates the assumption that GENITIVALS do carry a [DEFINITE] feature, and since they are, as I argue, heads when occurring in POSS₁, cf. section 5.2.4, it is, compatible with the idea that they are themselves determiner-like elements. I will essentially adopt this view with a minor modification to be made more precise in sections 6.4.1/6.4.2.

GENITIVALS in POSS₂, on the other hand, do not have the same impact. In the absence of another morpheme that carries the feature [DEFINITE], i.e. a definite determiner, the adjective must be inflected strongly. Bare weak inflection results in ungrammaticality (but see the appendix to this chapter), which is particularly blatant in cases where an alternative construal – e.g. as vocative or double parsing as in (294b) vs. (294c) – is not available:

- (297) a. [?]algjör.a eyðilegging hans / Sesars á borginni
total.WK destruction his / Cesar.GEN on city.the
- b. hin algjör.a eyðilegging hans / Sesars á borginni
ART total.WK destruction his / Cesar.GEN on city.the
- c. algjör. eyðilegging hans / Sesars á borginni
total.STR destruction his / Cesar.GEN on city.the
'his/Cesar's total destruction of the city'

²For reasons not entirely clear to me, constellations like (296b), i.e. ADJ N POSS NUM without DEF on the head noun, are generally somewhat deviant, and the superscript question marks are meant to indicate that my informants considered it hard to judge such examples. This goes especially for (296b-ii) with a strongly inflected adjective: one informant tells me that it is categorically bad, another that it is not possible to have a clear intuition about it. (296b-i), on the other hand, is largely considered acceptable or slightly marginal. Interestingly, some native speakers consider the following example to be the best solution, namely with DEF on the head noun:

- (1) ^{ok?}snjöll.u bræður - nir hans þrír ~~snjöll.u bræður~~
clever.WK brothers - DEF his three

This is unexpected insofar as kinship terms do not normally take the suffixed article in *possessive constructions*, see next section, and the same informants that accept this example, would not accept the suffixed article in comparable examples without adjectives. Clearly, this needs to be investigated further.

- (298) a. ✗ algjör.a eyðilegging hennar / borgarinnar
total.WK destruction her / city.the.GEN (NB: *borg* ‘city’ is feminine)
- b. hin algjör.a eyðilegging hennar / borgarinnar
ART total.WK destruction her / city.the.GEN
- c. algjör. eyðilegging hennar / borgarinnar
total.STR destruction her / city.the.GEN
‘its total destruction / the total destruction of the city’
- (299) a. ✗ meint.i vinur hans / Jóns
alleged.WK friend his / Jón.GEN
- b. hinn meint.i vinur hans / Jóns
ART alleged.WK friend his / Jón.GEN
- c. meint.ur vinur hans / Jóns
alleged.WK friend his / Jón.GEN
‘his / Jón’s alleged friend’

Even if these GENITIVALS are definite (let us assume they are), they cannot trigger weak inflection. I submit that this is so because the low position POSS₂ does not c-command any adjective.

Thus the discussion so far rather obviously and strongly corroborates one central claim of this thesis: weak inflection is triggered by a c-commanding determiner carrying the feature [DEFINITE]; bare weak inflection is illicit. In the absence of an appropriate trigger, the adjective is, by default, strongly inflected. I have identified (X⁰) GENITIVALS in POSS₁ as potential triggers, and likewise shown that (XP) GENITIVALS occupying POSS₂ are not potential triggers because they do not c-command adjectives.

At this juncture it is important to point out that what I have been calling pattern (IV) has two major features: (i) overt realization of DEF, which entails a high position of *ixP* (in *Spec-articleP*), and (ii) a strongly inflected adjective that is merged outside *articleP*. Now, as has already been mentioned, and will be discussed in more detail below, in certain *possessive constructions*, the head noun does not carry DEF, but may still be in its high position (it precedes numerals, see above). Conversely, in some cases, especially with *DP-genitives*, *ixP* fails to move to *Spec-articleP* altogether (meaning the head noun does not carry DEF, either). This has consequences for diagnosing the position strong adjectives; consider the following examples:

- (300) a. Ég gekk um tóm.ar götur - nar
I walked around empty.STR streets - DEF
- b. Ég gekk um tóm.ar götur borgarinnar
I walked around empty.STR streets city.the.GEN

- c. Ég gekk um tóm.ar götur hennar
I walked around empty.STR streets her (NB: *borg* ‘city’ is feminine)
- (301) a. aut.t rúm - ið hennar fóstru
empty.STR bed - DEF [she foster-mother]-GEN
- b. aut.t rúm (*-ið) sjúklingsins
empty.STR bed -DEF patient.the.GEN

(300a) is a straightforward pattern (IV) noun phrase, with *ixP* occupying its high position *Spec-articleP*. In (300b), *ixP* occupies its low base position and the *DP-genitive* occupies $POSS_2$ (see (270)); and in (300c) the sequence N POSS is, at least in principle, ambiguous. But the interpretation of the adjective is the same in all cases, viz. appositive: ‘... (the/its) streets (of the city) which happened to be empty’. If the strongly inflected adjective is (visibly) outside *articleP* in (300a) as I argue, then there is no obvious reason to doubt that it is in the same place in examples (300b/c) as well, even though DEF is not realized for independent reasons. The same reasoning applies to (301). In other words, we have to admit the existence of “covert pattern (IV)” noun phrases that do not involve DEF.

Yet we have just seen a number of examples that bear an uncanny resemblance to those covert pattern (IV) cases, for instance the c-examples in (297) through (299). This means that, given what has been established so far, we must allow for two construals of the surface sequence A.STR N GENITIVAL, one in which the adjective is merged *articleP*-externally, i.e. pattern (IV), and one in which the adjective is merged *articleP*-internally (which entails that *ixP* is in its base position and the *DP-genitive* occupies $POSS_2$).

The modifiers that occur *articleP*-externally are essentially those that we generally find in pattern (IV) constellations anyway, typically appositives (but also expressives, positional predicates, and little partitives; see chapter 3). But the present concern is to show that strongly inflected adjectives in an apparently identical surface pattern may be merged in a different structural location, namely *articleP*-internally. There are two simple ways to illustrate this. Recall that numerals preceding the (strongly inflected) adjective are an unambiguous diagnostic for the latter being merged *articleP*-internally:

- (302) a. þrír snjall.ir bræður hans
three clever.STR brothers his
- b. fimm ung.ir þingmenn Sjálfstæðisflokksins
five young.STR MPs independence-party.the.GEN

Likewise, adjectives that normally occur visibly inside *articleP*,³ must be as-

³Recall that adjectives like ‘so-called’, ‘alleged’ and many others cannot occur in pattern (IV), but only in some weak pattern, and thus *articleP*-internally.

sumed to occur *articleP*-internally in *possessive constructions* as well, even with no article present:

- (303) a. *meint.ur* (**meint.i*) *sjúkdómur minn*
 alleged.STR —.WK disease my
 ‘my alleged disease’
- b. *meint.ur* (**meint.i*) *morðingi hundsins*
 alleged.STR —.WK murderer dog.the.GEN
 ‘the alleged murderer of the dog’
- c. *svokallað.ur* (**svokallað.i*) *vinur minn*
 so-called.STR —.WK friend my
 ‘my so-called friend’
- d. *svokölluð.* (**svokallað.a*) *rúmfræði Evklíðs*
 so-called.STR —.WK geometry Euclid.GEN
 ‘the so-called Euclidean geometry’

Recall that one core tenet of my proposal is that adjectival inflection is not semantically contentful (contra Julien 2005a,b and Lohrmann 2008, 2010), and strong inflection does not entail or express (semantic) indefiniteness. This is especially evident from examples like (303): the *articleP*-internal adjectives are strongly inflected, but the noun phrase as a whole can hardly be construed as indefinite. On my account, the strong inflection is simply the result of the fact that the weak inflection is not triggered because there is no *c*-commanding [DEFINITE].

I will further defend this position in the following where I examine the semantic contribution of GENITIVALS regarding definiteness.

6.1.1 (In-) Definiteness and Possession

For all intents and purposes, a noun phrase like (304) is definite by itself:

- (304) *hattur kennarans*
 hat teacher.the.GEN
 ‘the teacher’s hat’

One may ask what the formal status of definiteness in such examples is, and whether the GENITIVAL by itself contributes to the (in-) definiteness of the overall noun phrase.⁴ As a point of departure, consider the following (extended) statement

⁴The latter question has often been answered in the affirmative in the literature on *possessive constructions*. The underlying idea is that the DP as a whole inherits its definiteness value from the (definite or indefinite) *possessor*; see the behaviour of possessed DPs in existential sentences:

- (1) a. There is [a tall man]’s lawyer in the garden (Barker 2011:1119)
 b. *There is [the tall man]’s lawyer in the garden

by (Julien 2005b:242/3; underlining mine, A.P.):⁵

... in [(305)] we see two [...] examples, which show that possessed Icelandic DPs can also be indefinite. In the absence of marking on the noun it is the indefinite form of the adjective that shows that these DPs are indeed indefinite.

- (305) a. %slitin.n hattur gamals manns
worn.STR hat [old man]-GEN
'an old man's worn hat'
b. %slitin.n hattur kennarans
worn.STR hat teacher.the.GEN
'a worn hat belonging to the teacher'

So we see that the presence of a possessor does not in itself make the larger DP definite for all speakers of Icelandic. But note that the definiteness of the larger DP is not determined by the definiteness of the possessor either. In [(305a)] the possessor is indefinite and in [(305b)] it is definite, yet the larger DP is indefinite in both examples. Thus for those speakers who have a grammar where a possessor does not trigger definiteness, a DP with a genitive possessor is free to be definite or indefinite.

I will adopt the essence of her conclusion (“a DP with a genitive possessor is free to be definite or indefinite”) with a minor modification:

- (306) A noun phrase without (overt) definite determiner, but with a GENITIVAL in POSS₂ is *indeterminate* (or underspecified) with respect to (in-) definiteness.

I will, however, take issue with some aspects of her argument. First of all, recall that on the present account, strong inflection must not be equated with indefiniteness. I have argued at length that labeling strong inflection as the “indefinite form of the adjective” is misleading. In addition, strong inflection does not, in fact, show “that these DPs are indeed indefinite”. It is important to notice that a possessed noun phrase with with a GENITIVAL in POSS₂, in principle, allows both an indefinite and a definite reading:⁶

- | | |
|--------------------------------|-------------------------|
| (307) a. hattur kennarans | b. systir hans |
| hat teacher.the.GEN | sister his |
| i. 'a hat of the teacher's' or | i. 'a sister of his' or |
| ii. 'the teacher's hat' | ii. 'his sister' |

⁵NB: both examples in (305) are actually fine. In (Julien (2005a):248) where she discusses the same examples, she omits the “%”.

⁶Strictly speaking, (307b) is potentially ambiguous between two structures, cf. (294b) vs. (294c), i.e. it is not really clear that the *pronominal possessive* does occupy POSS₂, but see below.

This means that example (305b) not only has an indefinite reading as indicated by Julien's own paraphrase, but also a definite reading ('the teacher's worn hat'). The strong inflection does not in any way suggest that the noun phrase is indefinite. As a matter of fact, we have already encountered several examples of this kind that actually strongly prefer the definite reading:

- (308) a. algjör. eyðilegging Sesars á borginni
total.STR destruction Cesar.GEN on city.the
'Cesar's total destruction of the city'
- b. ný. kenning Darwins
new.STR theory Darwin.GEN
'Darwin's new theory'
- c. ástkær. eiginmaður minn
beloved.STR husband my
'my beloved husband'
- d. tvær ung.ar dætur þeirra
two young.STR daughters their
'their two young daughters'

So even though these noun phrases are not *formally* definite (in the sense that they lack morphological definiteness marking, i.e. DEF or a definite determiner, they can be said to be *semantically* definite, or rather *pragmatically* definite. The fact that adjectival modifiers occur strongly inflected clearly shows that strong inflection does not amount to indefiniteness marking on the adjective, and that a strongly inflected adjective certainly does not commit the noun phrase to be indefinite. This is, of course, expected on the present account where strong inflection is taken to simply indicate the absence of definiteness marking on the adjective, and the absence of formal definiteness marking does not automatically imply indefiniteness.

But although both a definite and an indefinite reading are, in principle, available, we should not consider this a systematic ambiguity. This "freedom" to be definite or indefinite is rather hard to describe or capture formally for even though the indefinite reading is, in principle present, it cannot always be "accessed". Icelandic displays *Definiteness Effects* in existential sentences similar to English (see for instance Vangsnes 2002). Thus existential sentences are a bona fide means to determine whether a given noun phrase is (formally) definite or not:

- (309) a. *Definite*:
*það er maður-inn / þessi maður / Jón / hann í garðinum
it is man-DEF / this man / Jón / he in garden.the
'*there is the man / this man / Jón / he in the garden'

b. *Indefinite:*

- i. það er (fræg.ur) maður / einhver maður / enginn maður í garðinum
 it is (famous.STR) man / some man / no man in garden.the
 ‘there is a (famous) man / some man / no man in the garden’
- ii. það eru þrír (fræg.ir) menn í garðinum
 it are three (famous.STR) men in garden.the
 ‘there are three (famous) men in the garden’

Now consider *possessive constructions* without overt definiteness marking in existential sentences:

- (310) a. *það er (rauð.ur) bíll hans / Jóns í garðinum
 it is (red.STR) car his / Jón.GEN in garden.the
- b. *það er (fræg.ur) bróðir hans / Jóns í garðinum
 it is (famous.STR) brother his / Jón.GEN in garden.the
- cf.: there is a (red) car of his / Jón’s in the garden
 there is a (famous) brother of his / Jón’s in the garden

The Icelandic examples in (310) are bad although we have seen that the indefinite reading is, in principle, available (the corresponding English examples are indeed fine in this context). Note that it does not seem to matter whether the head noun is a kinship term or a common noun, nor whether the GENITIVAL is pronominal or non-pronominal. Note further that bare head nouns, i.e. head nouns without pronominal modifiers, are categorically bad in this construction, and typically, the addition of a (strongly inflected) adjective does not help to improve.⁷ If strong inflection as such did reflect the indefiniteness of a noun phrase, we would expect that it did.

Thus solely judging from their badness in existential sentences, we should conclude that noun phrases of the type (A.STR) N DP.GEN / POSS are actually definite. But now consider the following examples:

- (311) a. það er einn (rauð.ur) bíll hans / Jóns í garðinum
 it is one (red.STR) car his / Jón.GEN in garden.the
 ‘there is one (red) car of his / of Jón’s in the garden’
- b. það eru þrír (fræg.ir) bræður hans / Jóns í garðinum
 it are three (famous.STR) brothers his / Jón.GEN in garden.the
 ‘there are three (famous) brothers of his / of Jón’s in the garden’

⁷There are some exceptions:

- (1) ^{ok}það er gamal.l vinur þinn í símanum
 it is old.STR friend your in phone.the
 ‘there is an old friend of yours on the phone’

This is furthermore in line with the above observation that only GENITIVALS in POSS₁ trigger weak inflection on (*articleP*-internal) adjectives.

Even though we have observed in this subsection that noun phrases involving low GENITIVALS do allow – and often favour – a definite reading and that they may be subject to (not entirely understood) definiteness effects, I have argued that GENITIVALS occupying the low position POSS₂ do not make the noun phrase formally definite, i.e. they do not contribute [DEFINITE] to the overall noun phrase. Likewise we have seen that GENITIVALS in POSS₂ do not trigger the weak inflection on (*articleP*-internal) adjectives, by assumption, for the same reason. For even though they may carry the feature [DEFINITE], they are merged too low for it to have a syntactic impact. On the other hand, I have shown that GENITIVALS that are merged in the high position do have an impact in that they do make the noun phrase formally definite and they do trigger the weak inflection on (*articleP*-internal) adjectives.

6.2 Pronominal Possessives and DEF

So far the fact that *pronominal possessives* sometimes co-occur with DEF has been left uncommented. This will be addressed in this section, but let us first recapitulate some structural facts already discussed in section 5.2.2. Essentially, we have three parameters: (i) POSS₁ vs. POSS₂, (ii) presence vs. absence of DEF, and (iii) *ixP*-movement (to *Spec-articleP*) vs. no movement. Since DEF carries the feature [**ix**] that triggers *ixP* movement, the presence of DEF entails *ixP* movement. We have already seen, however, that this is not a biconditional, i.e. the opposite does not necessarily hold: *ixP* may move without the movement resulting in the suffixation of DEF, namely when there is a (postnominal) *pronominal possessive* in POSS₁. But without DEF or a *pronominal possessive* in POSS₁, *ixP* must remain in its low position. In particular, with a *pronominal possessive* occupying POSS₂, *ixP* cannot move (and DEF cannot be merged). In short, we have three constellations that need accounting for:

- (314) a. *ixP* -DEF POSS₁ *ixP*
 b. *ixP* POSS₁ *ixP*
 c. *ixP* POSS₂

In the last subsection, I addressed certain semantic aspects of *possessive constructions* pertaining to definiteness. But as already mentioned in section 5.1.2, there is another phenomenon that plays a crucial role in the semantics of *possessive constructions*, viz. relationality. Recall that *possessive constructions* express some relation between *possessor* and *possessum* (denoted by GENITIVAL and head

noun, respectively). On traditional accounts, the character of the relation is, at least in part, determined by the (semantics of the) head noun, a crucial distinction being between relational nouns and common nouns. Consequently, GENITIVALS are distinguished according to whether they are arguments of the noun or not. In the following, I will take a close look the Icelandic data and show that a mere distinction between common and relational nouns may not be sufficient. Notably, that latter group of alleged “argument-taking” nouns can be shown to display non-uniform behaviour. With some of those nouns (above all, kinship terms), a *pronominal possessive* (i.e. the GENITIVAL argument) may occur either in POSS₁ or POSS₂, while with others (nominalizations, part-whole nouns ...), it can only occur in the low position POSS₂.

With a *pronominal possessive* occupying POSS₁, common nouns in Icelandic normally carry DEF:

- | | | |
|-------|---------------------------------------|--|
| (315) | a. bíll - inn minn
car - DEF my | c. bíll - inn minn gamli
car - DEF my old |
| | b. hús - ið hennar
house - DEF her | d. hús - in hans tvö
houses - DEF his two |

Although (material) possession is one of the most salient relations expressed by examples like (315), it is by no means the only one. So (315a), for example, could mean ‘the car I own’, ‘the car I am renting’, ‘the car I drive when I am at work’, ‘the car I ordered (taxi)’ etc.. For these readings, I use the cover term *General Possessive Relation (GPR)*.¹⁰ The example *bíllinn minn* ‘my car’ can be given a semantic representation as follows:

- (316) $\iota x [\text{car}(x) \ \& \ \text{GPR}(\text{speaker}^c)(x)]$

Crucially, even though there may be pragmatical restrictions depending on the noun meaning,¹¹ GPR is not part of the noun denotation, but an addition, an external relation.

Cases involving prototypical relational head nouns such as kinship terms including nouns like ‘friend’, on the other hand, behave differently: they do not carry DEF in *possessive constructions* (Friðjónsson 1978; Sigurðsson 1993, 2006; Thráinsson 2007):

- (317) a. faðir (*-inn) minn / pabbi (*-nn) minn
father -DEF my / dad -DEF my
‘my father’ / ‘my dad’

¹⁰Covering both POSSESSION/CONTROL and Partee’s *freeR* readings.

¹¹For instance, ‘my house’ does not get the reading ‘the house I’m driving’ as easily as ‘my car’.

- b. systir (*-in) hans / systa (*-n) hans
 sister -DEF his / sis -DEF his
 ‘his sis(ter)’
- c. sonur (*-inn) okkar / dóttir (*-in) okkar
 son -DEF our / daughter -DEF our
 ‘our son’ / ‘our daughter’
- d. vinur (*-inn) þinn / vinkona (*-n) þín
 friend(m) -DEF your / friend(f) -DEF your
 ‘your (male)/(female) friend’

Here the relation between *possessor* and *possessum* is lexically determined, and we have an *Inherent Possessive Relation* (IPR). The semantic representation for (317a) is given below:

$$(318) \quad \iota x [\text{IPR}_{\text{father}}(\text{speaker}^c)(x)]$$

While, for instance, the English Saxon genitive version ‘my father’ does allow a broad range of GPR readings, in addition to the lexically most salient IPR reading, Icelandic ‘faðir minn’ is very rigid, and can only have an IPR reading.¹² Thus in (317), the relation between *possessor* and *possessum* is not context-dependent or merely governed by pragmatic plausibility, but part of what the (head) noun means. Typically, this kind of *possessor* is construed as an argument of the noun.

On the face of it, examples (315) vs. (317) suggest that morpho-syntactic distinctions (presence vs. absence of DEF) systematically correspond to semantic distinctions (GPR vs. IPR):

$$(319) \quad \begin{array}{ll} \text{a. N - DEF POSS} & \Leftrightarrow \iota x [\text{N}(x) \ \& \ \text{GPR}(\text{possessor})(x)] \\ \text{b. N \quad \quad \quad POSS} & \Leftrightarrow \iota x [\text{IPR}_N(\text{possessor})(x)] \end{array}$$

(319) makes some rather strong predictions. In particular, it predicts that it is the absence vs. presence of DEF that determines whether the head noun is parsed as relational noun or common noun, and by extension, whether the *possessor* is construed as an inherent argument in an IPR, or as some participant in a GPR – not the noun’s lexical meaning. Consider the following examples:

$$(320) \quad \begin{array}{ll} \text{a. [móðir (*-in) hans}_y \text{]}_x & \text{b. [móðir - in hans}_y \text{]}_x \\ \text{mother -DEF his} & \text{mother - DEF his} \\ \rightarrow \text{IPR}_{\text{mother}}(y)(x) & \rightarrow \text{mother}(x) \ \& \ \text{GPR}(y)(x) \end{array}$$

We have already seen that kinship terms cannot be used with DEF, thus (320a) is unspectacular – at least in the case of mother-child relations. There are, however,

¹²In particular, it entails that the *possessor* is the *possessum*’s child.

construals where no such relation is intended. Imagine a group of women each of whom has at least one child (and is thus *a* mother), and another group of some random (male) persons. Members of both groups are supposed to team up and form pairs. Against this background, referring to a member of the latter group, one can felicitously use (320b) to mean ‘*x* is *a* mother and *x* is *y*’s partner’, without entailing that *y* is *x*’s son. This is the scenario described by (319a), and precisely in this kind of scenario, even kinship terms must carry DEF – as predicted.

Thus generalization (319) seems to be strongly supported: if the head noun carries DEF in a *possessive construction*, it is construed as a common noun and denotes a GPR, and the *possessor* can pretty much mean anything given an appropriate context. If the head noun does not carry DEF in a (*pronominal*) *possessive construction*, it is construed as a relational noun and denotes an IPR, and the *possessor* is interpreted as an argument of the head noun.

Of course, the situation is more complex insofar as the positional parameter (POSS₁ vs. POSS₂) mentioned above has not been touched upon. In order to highlight this issue, let us compare relational nouns like kinship terms to genuine argument-taking nouns like deverbal nominalizations:¹³

- (321) a. bróðir (*-inn) hans
brother -DEF his
- b. eyðilegging (*-in) hans á borginni
destruction -DEF his on city.the
- c. eyðilegging (*-in) hennar
destruction -DEF her (NB: *borg* ‘city’ is feminine)

As is the case with kinship terms, eventive AS nouns do not carry DEF in *possessive constructions* regardless of whether the *possessor* here denotes the AGENT or a THEME. If we consider the *possessors* in all three cases as arguments of the head noun on an equal footing, this observation as such is not remarkable. Rather it simply reinforces (319b). But the two groups of (head) nouns should be kept apart for several reasons.

¹³NB: The issue of nominalizations is rather complex, which to discuss here in detail would lead too far astray. I will focus on ‘regular’ cases of nominalizations. I am primarily interested in nominalizations of transitive verbs the basic patterns of which are:

- (1) a. N_{eventive} GENITIVAL_{AGENT} PP_{THEME}
b. N_{eventive} GENITIVAL_{THEME}
c. N_{result}-DEF

I will follow Grimshaw (1990) and distinguish between eventive argument-structure (AS) nouns (‘complex event nominals’ in her terminology), and resultant state (RS) nouns.

If the head noun is a kinship term, the *pronominal possessive* may occur either in POSS₂ or in POSS₁. In the latter case, this also means that the head noun occurs in its high position, i.e. *iXP* movement has taken place:

- (322) a. NUM >> A.STR >> N >> POSS₂
 tvær sæt.ar dætur mínar
 two cute.STR daughters my
 b. N >> POSS₁ >> NUM >> A.WK
 systur hans þrír snjöll.u
 sisters his three clever.WK

But if the head noun is an AS noun, *pronominal possessives* can only occur in the low position POSS₂, which I will illustrate in the following. Jóhannsdóttir (1995) shows that an eventive reading is available only if the THEME argument is realized, the AGENT being optional, cf. (323), whereas a resultant state reading is available if no argument is realized, cf. (324). Examples (323) and (324) are taken from (Jóhannsdóttir 1995:63):

- (323) a. Eyðilegging óvínarins á Róm stóð yfir í marga daga
 destruction enemy.the.GEN on Rome stood over for many days
 ‘The enemy’s destruction of Rome lasted for many days’
 b. *Eyðilegging óvínarins stóð yfir í marga daga
 destruction enemy.the.GEN stood over for many days
 c. Eyðilegging Rómar stóð yfir í marga daga
 destruction Rome.GEN stood over for many days
 d. *Eyðilegging - in stóð yfir í marga daga
 destruction - DEF stood over for many days
- (324) a. *Eyðilegging óvínarins á Róm er mikil
 destruction enemy.the.GEN on Rome is extensive
 b. *Eyðilegging óvínarins er mikil
 destruction enemy.the.GEN is extensive
 c. *Eyðilegging Rómar er mikil
 destruction Rome.GEN is extensive
 d. Eyðilegging - in er mikil
 destruction - DEF is extensive

Note that the examples in (323) and (324) actually involve *DP-genitives* (see next subsection). However, the relevant generalizations pertinent to the present context carry over to *pronominal possessives*:¹⁴

¹⁴NB: *Róm* ‘Rome’ is feminine, cf. the c-examples. Note further that (323b)/(325b) are fine if the GENITIVAL is parsed as THEME, i.e. on a reading where the enemy is destroyed.

- (325) a. Eyðilegging hans á Róm stóð yfir í marga daga
destruction his on Rome stood over for many days
'His destruction of Rome lasted for many days'
b. *Eyðilegging hans stóð yfir í marga daga
destruction his stood over for many days
c. Eyðilegging hennar stóð yfir í marga daga
destruction her stood over for many days
- (326) a. *Eyðilegging hans á Róm er mikil
destruction his on Rome is extensive
b. *Eyðilegging hans er mikil
destruction his is extensive
c. *Eyðilegging hennar er mikil
destruction her is extensive

There is another detail that should be observed. As the contrast (323d) vs. (324d) suggests, resultant state reading vs. eventive reading correlates with the presence vs. absence of DEF and thus with *ixP* movement taking place or not.

We have already seen, cf. (297)/(298), that two patterns of adjectival modification are available for nominalizations (on the eventive reading) with the *prenominal possessive* being either AGENT or THEME, repeated in (327); both involve the low position POSS₂. "Bare" weak adjectives, on the other hand, are bad:

- (327) a. ART >> A.WK >> N >> POSS₂
(i) hin algjör.a eyðilegging hans á borginni
ART total.WK destruction his on city.the
(ii) hin algjör.a eyðilegging hennar
ART total.WK destruction her
- b. A.STR >> N >> POSS₂
(i) algjör. eyðilegging hans á borginni
total.STR destruction his on city.the
(ii) algjör. eyðilegging hennar
total.STR destruction her
- c. *A.WK >> N >> POSS₂
(i) *algjör.a eyðilegging hans á borginni
total.WK destruction his on city.the
(ii) *algjör.a eyðilegging hennar
total.WK destruction her

Here is an addendum: postnominal adjectives are not possible in this constellation, either:¹⁵

¹⁵NB: AS nouns cannot be pluralized, which is in line with Grimshaw (1990):

(328) *N >> POSS₁ >> A.WK

- a. *eyðilegging hans algjör.a á borginni
destruction his total.WK on city.the
- b. *eyðilegging hennar algjör.a (cf.: bróðir hans snjall.i)
destruction her total.WK brother his clever.WK

Taken together, (321b/c), (323)/(325) vs. (324)/(326), and (327a/b) vs. (328) strongly suggest that eventive AS head nouns (i.e. the respective *ixPs*) always remain in their low position, and, more to the point, *pronominal possessives* always occur in the low position POSS₂ if they are genuine thematic arguments of the head noun. In this they differ strongly from *pronominal possessives* occurring with kinship terms which are quite happy in their respective high positions POSS₁ and Spec-*articleP*.

Incidentally, note that nominalizations on the resultant state reading behave like common nouns: they do carry DEF, they allow postnominal adjectives, they can be pluralized, and, crucially, the *possessive* occurs in POSS₁ (preceding adjectives and numerals):¹⁶

- (329) a. Eyðilegging - in er mikil
destruction - DEF is extensive
- b. eyðilegging - in mikla / algjöra
destruction - DEF great / total
- c. könnun - in mín góða (birtist í tímariti)
survey - DEF my good (was-published in journal)
- d. kannanir - nar hans tvær (birtust í tímariti)
surveys - DEF his two (were-published in journal)

Broadly speaking, we have thus identified three groups of nominals (common nouns, kinship terms, eventive AS nouns) in parallel to the three patterns identified in (314) above. In the following, I will refine this picture a bit. Note that there are other classes of nouns that are more or less plausibly construed as relational. Given the parameters [+/-DEF], [+/-MOVE-*ixP*] and [POSS₁] vs. [POSS₂], it can be shown that all head nouns in *pronominal possessive constructions* pattern like common nouns, like kinship terms, or like eventive AS nouns.

-
- (1) a. * <tvær> eyðilegging.ar hans <tvær> á borginni
two destruction.PL his two on city.the
- b. * <tvær> eyðilegging.ar hennar <tvær>
two destruction.PL her two

Since plural is thus generally bad, numerals cannot be used as a diagnostic in the same way.

¹⁶NB: *kann-a* ‘to investigate’ → *könn-un* ‘investigation (AS noun); survey (RS noun)’.

• Nouns denoting professional relations optionally carry DEF in *possessive constructions*:

- | | | | | | |
|-------|----|----------------------------|--|----|-----------------------------|
| (330) | a. | lögfræðingur (-inn) minn | | c. | hárskeri (-nn) minn |
| | | lawyer -DEF my | | | hair-dresser -DEF my |
| | b. | kennari (-nn) minn (góð.i) | | d. | læknir (-inn) minn (gaml.i) |
| | | teacher -DEF my good.WK | | | doctor -DEF my old.WK |

Note that, regardless of whether DEF is present or not, the position of the adjective in (330d) indicates that the *pronominal possessive* occupies POSS₁ (which entails that *ixP* movement has taken place). So these nouns alternately pattern with common nouns, cf. (315) or with kinship terms, cf. (317).¹⁷ Now, one can be a doctor or lawyer without being anyone's doctor or lawyer simply by having a diploma. In this sense, they are not as inherently relational as kinship terms. The presence vs. absence of DEF in the examples in (330) essentially displays the same contrast as (320a) vs. (320b), albeit not as obviously. Importantly, GPR readings are only available in the presence of DEF.

• Like kinship terms, other prototypical relational nouns such as nouns denoting part-whole relations, boundary nouns, and nouns denoting inherent properties ('size' or 'colour') do not carry DEF in *possessive constructions*:¹⁸

- | | | | | |
|-------|----|----------------------|---|--------------------------|
| (331) | a. | hluti (*-nn) hans | ~ | hluti arfsins (m) |
| | | part -DEF his | | part inheritance.the.GEN |
| | b. | þak (*-ið) þess | ~ | þak hússins (n) |
| | | roof -DEF its | | roof house.the.GEN |
| | c. | jaðar (*-inn) hennar | ~ | jaðar borgarinnar (f) |
| | | edge -DEF her | | edge city.the.GEN |
| | d. | tindur (*-inn) hans | ~ | tindur jökulsins (m) |
| | | peak -DEF his | | peak glacier.the.GEN |
| | e. | stærð (*-in) hennar | ~ | stærð konunnar |
| | | size -DEF her | | size woman.the.GEN |

¹⁷In addition, we often find idiosyncratic or conventionalized preferences:

- | | | | | | |
|-----|----|--------------------------------------|--|----|---------------------------|
| (1) | a. | vinnufélagi ([?] -nn) minn | | b. | starfsbróðir (*-inn) minn |
| | | "work.comrade" -DEF my | | | "job.brother" -DEF my |

Both examples can be rendered as 'my colleague/workmate'. It is hard, if not impossible to discern a semantic/truth-conditional difference. But *vinnufélagi* takes DEF in *possessive constructions* more easily than *starfsbróðir*, presumably because the latter contains the component "brother".

¹⁸The examples involving a *DP-genitive* on the right hand side in (331) are given for the sake of clarity: the pronominal *possessor*'s gender reference reflects the gender of the noun in the corresponding *DP-genitive*, not the *possessor*'s sex: *hluti hans* means "part of it (= the inheritance)", not "his part (of sth)" with "his" being a male *possessor*, cf. (331a).

Differently from kinship terms, however, the *pronominal possessives* involved in these cases cannot occur in POSS₁ if they are to denote the “internal” argument (such as the “whole” argument in the part-whole relationship), but must occur in POSS₂. *Pronominal possessives* occurring in POSS₁ express, as it were, an “external” argument denoting a POSSESSOR or CONTROLLER (the numeral in (332) is added for disambiguation; example (333) is repeated from (263b) and (264) above):

- | | | | |
|-------|--|-------|--|
| (332) | a. þrír hlutar hans
three parts his
<i>ok</i> ‘three parts of it’
b. hlutar hans þrír
parts his three
<i>ok</i> ‘his three parts (of sth)’
‘three parts of it’ | (333) | a. þinn hluti hans
your part his
‘your part of it’
b. hans hluti
his part
<i>ok</i> ‘his part (of sth)’
‘its part’ (i.e. ‘part of it’) |
|-------|--|-------|--|

In this respect, these nouns pattern with eventive AS nouns rather than with kinship terms. The GENITIVAL denoting the “whole” argument of the part-whole relation behaves like a GENITIVAL denoting a thematic argument of an eventive AS noun; in both cases, it can only occur in POSS₂.

• Another factor that is said to have an impact on presence vs. absence of DEF in *possessive constructions* lies in the dichotomy between *concrete* and *abstract* nouns (Friðjónsson 1978; Sigurðsson 1993, 2006; Thráinsson 2007). Concrete nouns require DEF in possessive constructions, abstract nouns disallow it:

- | | | | |
|-------|--|-------|--|
| (334) | a. bíll - inn þinn
car - DEF your
b. penni - nn minn
pen - DEF my | (335) | a. hugmynd (*-in) mín
idea -DEF my
b. skoðun (*-in) þín
opinion -DEF your |
|-------|--|-------|--|
- (336) a. Hvar er bók - in mín um íslenska setningafræði?
Where is book - DEF my on Icelandic syntax?
‘Where is my (copy of that) book on Icelandic syntax?’
b. #Hvar er bók mín um íslenska setningafræði?
Where is book my on Icelandic syntax?
c. Bók mín um íslenska setningafræði fékk góða dóma
book my on Icelandic syntax got good reviews
‘My book on Icelandic syntax got good reviews’
d. Bók - in mín um íslenska setningafræði fékk góða dóma
book - DEF my on Icelandic syntax got good reviews
(Thráinsson 2007:93)

- (337) a. bréf - ið þitt liggur á borðinu
 letter - DEF your lies on table.the
 ‘Your letter lies on the table’
 b. #bréf þitt liggur á borðinu
 letter your lies on table.the
 c. Í bréfi þínu stendur að...
 in letter your stands that ...
 ‘In your letter, it says that ...’
 d. Í bréfi - nu þínu stendur að...
 in letter - DEF your stands that ...

due to Jón Friðjónsson (class lectures, Spring 2006)

Examples (336a/b) and (337a/b) indicate that DEF is required if reference is made to an object, whereas (336c/d) and (337c/d) seem to suggest that it may be missing if the noun makes reference to a work or its content. On the other hand, (Sigurðsson 2006:23) states that DEF is actually dispreferred in that kind of context:

- (338) Allar bækur (??-nar) hans um listir hafa selst vel
 all books -DEF his on arts have sold well

At any rate, the question is what the underlying generalization is. Notions like ‘concrete’ vs. ‘abstract’ are rather vague and notoriously difficult to make usefully precise. Examples (335) through (337) suggest a token vs. type, or object vs. content distinction. But instead of trying to flesh out the notions ‘concreteness/abstractness’ merely with respect to the (head) noun, we should recast them in terms of relationality. Those cases with DEF on the head noun obviously fall under the heading GPR and are unproblematic. Examples without DEF usually given in this context (‘idea’, ‘opinion’; ‘book’ and ‘letter’ on their “abstract” reading) seem to be amenable to an analysis as relational nouns denoting *abstract possession/intellectual property* (or *authorship*). Given that the accompanying *possessive* can occur in POSS₁, we can conclude they pattern with kinship terms, rather than with part-whole denoting nouns:

- (339) a. hugmyndir þínar tvær (um íslenska setningafræði)
 ideas your two (about Icelandic syntax)
 b. bækur hans þrjár um íslenska setningafræði fengu allar góða dóma
 books his three on Icelandic syntax got all good reviews

One final observation: if a GENITIVAL occurs in POSS₁, the respective *possessor* must be [+HUMAN] irrespective of whether DEF is present or not. This applies to all cases we have examined in this section (and beyond). Conversely, if the *possessor* is inanimate, the GENITIVAL can only occur in POSS₂. This is, however, not to say that low GENITIVALS cannot denote [+HUMAN] *possessors*.

Let us recapitulate; we have three patterns of pronominal *possessive constructions*:

- (340) a. *ixP* -DEF POSS₁ *ixP*
 b. *ixP* POSS₁ *ixP*
 c. *ixP* POSS₂

I will first address the cases involving POSS₁. The first case (340a) is rather straightforward. The head noun is parsed as common noun and the *possessor* denoted by the *pronominal possessive* as a participant in a GPR. Head nouns in the second case (340b) are parsed as relational (subsuming kinship terms, “flexible” relational nouns denoting professional relations, and “abstract” relational nouns like “idea” or “book” denoting intellectual property), and the *possessor* is construed as an argument of an IPR. In both these cases, the *possessor* is [+HUMAN].

In chapter 4, I proposed that DEF carries a feature [**ix**] that triggers movement of *ixP* from its base position to Spec-*articleP*. Apart from the morphological manifestation of the suffixed article on the head noun as such, we have seen that the position of stranded numeral and adjectival modifiers is indicative of *ixP* movement: if the head noun precedes the modifier, *ixP* movement must have taken place. However, we have cases like (340b) where, by the latter criterion, *ixP* movement must be assumed to have taken place even though there is no overt DEF:

- (341) bræður Ø mínir þrír
 brothers my three

I propose that certain *pronominal possessives* themselves carry the feature [**ix**], but it is inert or uninterpretable in POSS₁, and the *pronominal possessive* must therefore raise to *article*⁰.¹⁹ From this position, it triggers *ixP* movement to Spec-*articleP* (and preempts/blocks merger of DEF).

Furthermore I submit that this process also has a semantic consequence, which we can envision as type shifting. More specifically, I propose that raising from POSS₁ to *article*⁰ shifts the *pronominal possessive* from a modifier type to a determiner type. That is, the output of that raising operation is a possessive determiner that takes a relation as an argument akin to Partee’s (1983/1997) analysis of pronominal (Saxon) GENITIVALS. Recall from section 5.1.2 that Partee assumes two distinct lexical entries for GENITIVALS depending on whether they combine with a common noun or a relational noun:

¹⁹Strictly speaking, this assumption entails head movement. While I will stick to the X⁰ movement parlance for the ease of exposition, I will assume that that operation is more appropriately thought of as spanning: certain *pronominal possessives* spell out the sequence *article* - POSS₁.

- (342) a. with common noun: free R-variable
 $\llbracket \text{Mary's}_{DET_1} \rrbracket = \lambda P. \iota z. P(z) \ \& \ \mathbf{R}(\text{Mary})(z)$
 b. with relational noun: inherent R
 $\llbracket \text{Mary's}_{DET_2} \rrbracket = \lambda \mathbf{R}. \iota z. \mathbf{R}(\text{Mary})(z)$

I will adopt Partee's idea with some modifications. The idea is the following: *Pronominal possessives* come in two flavours, GPR and IPR. When merged in POSS_1 , however, they have merely a modifier – not a determiner – denotation. This is for the simple reason that definiteness is spelled out separately as DEF in cases like (340b).²⁰ In other words, we have the following initial denotations for *pronominal possessives*:

- (343) a. $\llbracket [_{Poss^0} \text{pinn}] \rrbracket = \lambda P. \lambda z. P(z) \ \& \ \mathbf{R}(2^c)(z)$ GPR
 $\llbracket [_{Poss^0} \text{hans}] \rrbracket = \lambda P. \lambda z. P(z) \ \& \ \mathbf{R}(\llbracket \text{he} \rrbracket^g)(z)$
 b. $\llbracket [_{Poss^0} \text{minn}] \rrbracket = \lambda \mathbf{R}. \lambda z. \mathbf{R}(1^c)(z)$ IPR
 $\llbracket [_{Poss^0} \text{hennar}] \rrbracket = \lambda \mathbf{R}. \lambda z. \mathbf{R}(\llbracket \text{she} \rrbracket^g)(z)$

The reference of the respective *possessor* is determined by the pronominal's ϕ features. GPR possessives normally stay in their position and the determiner DEF is merged in *article*⁰ contributing the iota operator. IPR possessives, on the other hand, must raise to *article*⁰ whence they trigger *ixP* movement, by assumption because they carry the feature [**ix**], which is uninterpretable in POSS_1 . As a consequence of raising, the *pronominal possessive* has shifted to a determiner, and contributes the iota operator itself:

- (344) a. $\llbracket [_{article^0} \text{minn}] \rrbracket = \lambda \mathbf{R}. \iota z. \mathbf{R}(1^c)(z)$ IPR
 $\llbracket [_{article^0} \text{hennar}] \rrbracket = \lambda \mathbf{R}. \iota z. \mathbf{R}(\llbracket \text{she} \rrbracket^g)(z)$
 b. $\llbracket [_{article^P} \text{bróðir minn}] \rrbracket = \iota z. \mathbf{R}_{brother}(1^c)(z)$

I will flesh out this idea in more detail after having discussed pronominal GENITIVALS in section 6.4.2.

As for cases involving *pronominal possessives* in POSS_2 as in (340c) and in what respect they differ from *pronominal possessives* in POSS_1 ,²¹ I will only give some preliminary comments. The question cannot be fully answered yet because an analysis of POSS_2 is confronted with a serious syntactic problem which, in turn, cannot be fully assessed without taking a closer look at *DP-genitives* first (see next

²⁰For the sake of brevity, I will simply equate definiteness with the iota operator.

²¹We have already addressed one syntactic difference between the GENITIVAL positions: POSS_1 is a head position, whereas POSS_2 is an XP. Descriptively, we can compare this distinction to the distinction possessive determiners vs. possessive PPs in English. Thus, informally, we could make this distinction visible in the glosses to a certain extent:

subsection). I will return to that question in more detail in section 7.2 where I develop an analysis of POSS₂.

For the moment we can say this: On the one hand, we find a rather specific group of argument-taking head nouns that necessarily involve the low position POSS₂. Here the *possessor* is systematically construed as an argument of an IPR denoted by the respective head noun: either as a thematic argument of a deverbal head noun or as the “whole” argument with part-whole relational nouns. The *possessor* can be [+/-HUMAN]. Incidentally, discussing the former case we have seen an interesting interpretive effect for deverbal head nouns: the eventive reading is only possible if *ixP* occurs in its low base position; if it moves to *Spec-articleP*, on the other hand, only the resultant state reading is possible.

But we have seen that the low positions are more widely available. Other IPR denoting nouns like kinship terms occur either high or low with the *pronominal possessive* occupying either POSS₁ or POSS₂, respectively. We also have to concede that a constellation like (340c) emerges as a consequence of *ixP* not taking place for different reasons. For instance, possessed noun phrases with an “indeterminate” reading discussed in the previous section belong into this group. Likewise, *ixP*-movement does not take place when ART occurs in the article position (i.e. when ‘h’ is merged in *Spec-articleP*). In addition, recall that *DP-genitives* only occur in POSS₂ (see next section). In those latter cases, the possessive relation cannot unambiguously be characterized as IPR, but we must concede that GPR is possible as well (*hattur kennarans* ‘hat teacher.the.GEN).

(1) a. ⇒ POSS₁

- i. bíll - inn **minn**
‘my car’
- ii. bróðir **þinn**
‘your brother’
- iii. bók **hans** um X
‘his book about X’
- iv. **minn** hluti hans
‘my part of it’

b. ⇒ POSS₂

- i. bíll **minn**
‘car of mine’
- ii. bróðir **þinn**
‘brother of yours’
- iii. eyðilegging **hennar**
‘destruction of it’
- iv. minn hluti **hans**
‘my part of it’

6.3 DP-Genitives and DEF

As a rule, the head noun does not carry DEF when followed by a *DP-genitive*:

- (345) a. bíll (*-inn) Jóns / mannsins
 car -DEF Jón.GEN / mann.the.GEN
 b. bók (*-in) hins mikla heimspekings
 car -DEF [ART great philosopher]-GEN

There are two notable exceptions. The first one applies generally in colloquial standard Icelandic: with the *DP-genitive* headed by a so-called proprial article,²² the head noun normally carries DEF. Note that the proprial article is only felicitous with a proper name or a kinship term, not a (definite) common noun, cf. (346a). The second exception is a matter of dialectal variation: in certain dialects in northern Iceland (Ólafsfjörður,²³ Siglufjörður, Hófsós) and the Vestfjords, the head noun can carry DEF when followed by a *DP-genitive* even in the absence of the proprial article, and even if the *DP-genitive* involves a mere common noun, cf. (346b):²⁴

- (346) a. bíll - inn hans Jóns / hans pabba / * hans mannsins
 car - DEF [he Jón]-GEN / [he dad]-GEN / [he mann.the]-GEN
 b. %bíll - inn Jóns / mannsins / hins mikla heimspekings
 car - DEF Jón.GEN / mann.the.GEN / [ART great philosopher]-GEN

Even though the existence of dialectal varieties like (346b) has been mentioned in the literature (Sigurðsson 1993, 2006; Thráinsson 2007), no systematic inquiry into their exact nature has been conducted. To be fair, there have been studies of the phenomenon as such, above all Ottósdóttir (2006) who conducted a detailed field study. Her primary concern, however, is the regional distribution of that pattern and the acceptability among different age groups (of simple examples such as *peysa-n mömmu* ‘sweater.DEF mum.GEN’ or *bíll-inn Jóns* ‘car-DEF Jón.GEN’). Not addressed are the issues of relationality and the semantic properties of head noun and GENITIVAL in this respect.

²²Formally identical to third person pronouns, which is why I will gloss it as such. The proprial article will be separately addressed in more detail below.

²³This phenomenon is sometimes referred to as *Ólafsfjarðareignarfall* ‘Ólafsfjord-Genitive’; see for instance Ottósdóttir (2006).

²⁴In addition, we find some more or less fixed expressions of the type N-DEF DP.GEN that are acceptable even in standard Icelandic:

- (1) nýju föt - in keisarans
 new clothes - DEF emperor.the.GEN
 (originally, the title of a fairy tale by H. C. Andersen)

Pending an inquiry into those semantic aspects, I will make some preliminary observations. First of all, as far as I can tell, all the head nouns that are (or can be) used in the dialectal pattern illustrated in (346b) are parsed as common nouns with the *possessive construction* as a whole denoting a GPR. So with respect to definiteness marking on the head noun, these cases behave like their pronominal (GPR) counterparts. The same goes for the colloquial version involving the proprial article:

- (347) a. %bíl - **inn** Jóns
car - DEF Jón.GEN
b. bíll - **inn** hans Jóns
car - DEF [he Jón]-GEN
c. bíll - **inn** hans
car - DEF his

Also, the contrast in (346a/b) shows that the dialectal pattern is compatible with a broader range of *DP-genitives* than the colloquial one employing the proprial article in that the former may involve common nouns ('the man's', 'the philosopher's'). Nonetheless, there are limitations on the use of DEF on the head noun when followed by a *DP-genitive*, even in those dialects:

- (348) a. vinur (*-inn) Jóns
friend -DEF Jón.GEN
b. bíll (*-inn) framtíðarinnar
car -DEF future.the.GEN

The bottomline seems to be this: in cases where DEF on the head noun is bad with a *pronominal possessive*, then, a fortiori, it is bad with a *DP-genitive* – regardless of whether the *DP-genitive* is headed by a proprial article (where felicitous), and – as far as I can tell – regardless of dialect:

- (349) ⇒ Relational head noun: kinship
a. bróðir (*-inn) (hans) pabba / (hans) Jóns
brother -DEF [(he) dad]-GEN / [(he) Jón]-GEN
b. móðir (*-in) mannsins / hins mikla heimspekings
mother -DEF man.the.GEN / [ART great philosopher]-GEN
(350) ⇒ Relational head noun: part-whole
a. hluti (*-nn) arfsins
part -DEF heritage.the.GEN
b. þak (*-ið) hússins (Thráinsson 2007:93)
roof -DEF house.the.GEN
(351) ⇒ Deverbal AS head noun
a. eyðilegging (*-in) (hans) Sesars á borginni
destruction -DEF [(he) Cesar]-GEN on city.the
b. eyðilegging (*-in) borgarinnar
destruction -DEF city.the.GEN

- b. NUM >> A.STR >> N >> POSS₂
 (einn) slitin.n hattur kennarans
 one worn.STR hat teacher.the.GEN

The interesting cases are those where *ixP* movement has taken place as indicated by the presence of DEF:

- (354) N - DEF >> NUM >> A.WK >> ~~N~~ >> POSS₂ cf. (269)
- a. hestur - inn frægi hans afa
 horse - DEF famous [he grandfather]-GEN
- b. Palestínuljóð - ið fræga Kristjáns frá Djúpalæk
 Palestine-song - DEF famous Kristján.GEN from Djúpalækur
- c. bækur - nar fjórir hans Péturs
 books - DEF four [he Pétur]-GEN
- d. myndir - nar þrjár frægu Astridar af Dorian Gray
 pictures - DEF three famous Astrid.GEN of Dorian Gray

So even though *ixP* is in its high position, the *DP-genitive* is still in its low position as it follows all postnominal (numeral and adjectival) modifiers. GENITIVALS, i.e. *pronominal possessives*, occupying the high position POSS₁ precede them; compare:

- (355) a. ⇒ GENITIVAL in POSS₁
- i. hestar - nir hans þrír
 horses - DEF his three
- ii. *hestar - nir (hans) Jóns þrír
 horses - DEF [he Jón]-GEN three
- b. ⇒ GENITIVAL in POSS₂
- i. *hestar - nir þrír hans
 horses - DEF three his
- ii. hestar - nir þrír (hans) Jóns
 horses - DEF three [he Jón]-GEN

I will refer to the constellation *ixP* movement + *DP-genitive* in POSS₂ as *genitive stranding*. Now, we know that *ixP* may occur in its high position *Spec-articleP* even if it is not overtly marked with DEF – iff there is a *pronominal possessive* in POSS₁:

- (356) a. bræður hans þrír
 brothers his three
- b. *bræður þrír hans
 brothers three his

Thus even though we have established that *DP-genitives* always occur in the low position regardless of whether *ixP* moves or not, examples like (356a) might

still give rise to the expectation that genitive stranding may occur in the absence of DEF. This expectation is not borne out:

- (357) *bræður þrír (hans) Jóns
 brothers three [he Jón]-GEN

Incidentally, this observation corroborates the proposal put forth in the previous subsection that it is the *pronominal possessive* in examples like (356a) that triggers *ixP* movement, rather than, say, a zero article.

We can summarize these findings as follows: *DP-genitives* always occur in the low position $POSS_2$. Normally, *ixP* remains in its base position, but under certain conditions, DEF can be merged thus triggering *ixP* movement and stranding the *DP-genitive*. So we have two surface patterns:

- (358) a. ixP $POSS_2$
 b. ixP -DEF ixP $POSS_2$

I have argued that there is a subtle interpretive difference. If the *possessive construction* denotes an IPR, genitive stranding is categorically bad even if those “certain” conditions are fulfilled. On the other hand, genitive stranding is only possible iff the *possessive construction* denotes a GPR and those conditions are fulfilled.

Note that (358a) is the only constellation that is also found with *pronominal possessives*, cf. (340c). (358b) is, in part, comparable to (340a) with respect to merger of DEF and subsequent *ixP* movement: in both cases, the head noun must be (parsed as) a common noun, and the possessive relation is a GPR.

6.3.1 A Note on the Proprial Article

In colloquial speech, certain nouns denoting specific human beings, viz. kinship terms and proper names (of persons), are typically preceded by so-called proprial articles²⁶ which are formally identical to personal pronouns.²⁷ Above we saw some

²⁶To my knowledge, the claim that those elements are, in fact, a species of definite article, was first made (for Icelandic) by (Magnússon 1984:96). Sigurðsson (2006) gives a detailed discussion of this and related constructions (see also Thráinsson 2007). Broader investigations into the matter have been conducted for instance by Delsing (1993) and Julien (2005a) showing that proprial articles are also found in many Norwegian and some (northern) Swedish dialects. There seems to be broad consensus that proprial articles are the same elements as those definite articles occurring with proper names in languages like German or Greek. However, as the co-occurrence of proprial article and DEF in (360a) shows, the two cannot be assumed to occupy the same position.

²⁷“The ICELANDIC PROPRIAL ARTICLE is a personal pronoun that stands next to the left of a name or a relational noun, without there being any intonation break between the two” (Sigurðsson

examples of proprial articles accompanying *DP-genitives*, but note that they are fully inflected and agree with the head noun in case, number and gender (where “number agreement” extends to cases involving a plural pronoun and a conjunction of two singular head nouns as in (360b-d)):

- | | |
|--|---|
| (359) Singular | (360) Plural |
| a. hann pabbi
[he dad]-NOM | a. þeir bræður-nir
[they brothers-DEF]-NOM |
| b. hana frænku mína
[she aunt my]-ACC | b. þeim Siggu og Maríu
[they Sigga and María]-DAT |
| c. honum Jóni
[he Jón]-DAT | c. þeir Jón og Sigurður
[they.MASC Jón and Sigurður] |
| d. hennar Sigríðar
[she Sigríður]-GEN | d. þær Sigga og María
[they.FEM Sigga and María] |

The glossing requires commenting²⁸ because the notation has theoretical implications for *possessive constructions*. Consider the following example:

- (361) a. bók - in hennar Maríu
book - DEF [she María]-GEN
'María's book'

Here the gloss suggests that the *DP-genitive* is merely the genitival form of a proprial article construction as in (359). This apparently harmless descriptive suggestion comprises two related, but distinct theoretical claims: (i) the pronominal element in *DP-genitives* of the kind illustrated in (361) really is just the genitival form of the proprial article, and (ii) this genitival proprial article in *possessive constructions* (glossed as 's/he.GEN') is **not** syntactically a third person pronominal *possessive* (glossed as 'his'/'her') – in spite of their formal/morphological identity (cf. table 5.3). Moreover, this way of glossing suggests that pronominal and head noun in a *DP-genitive* as in (361) are a constituent.

These points are not trivial; they have all been challenged in the literature. So it has been argued that the pronominal element in a *DP-genitive* is, in fact,

2006:229). So even though we will, for the most part, be concerned with third person proprial articles, the definition also includes first and second person, examples of which are given below. Another crucial part of this definition that should be borne in mind - *no intonation break* - calls to attention the fact that the nominal part is not merely a parenthetical addition to the pronominal part separated by comma intonation.

²⁸Strictly speaking, examples like (359c/d) – properly segmented as *hon.um Jón.i* and *hen.nar Sigríð.ar* – should be glossed as “he.DAT Jón.DAT” (or “him Jón.DAT”) and “she.GEN Sigríður.GEN” (or “her Sigríður.GEN”), respectively; see fn. 5.

the third person *pronominal possessive* (for instance Delsing 1998). Superficially, there seems to be plausible evidence to this claim; consider the following example:

- (362) a. hús Jóns (Delsing 1998:102)
house Jón.GEN
b. hús - ið hans
house - DEF his
c. hús - ið hans Jóns
house - DEF his Jón.GEN

On Delsing's account, the pronominal element *hans* in (362c) is construed as a *pronominal possessive* on a par with (362b) (hence the gloss 'his'). Specifically, he proposes that *hans* is merged in POSS⁰ (= POSS₁) in both (362b) and (362c) while *Jóns* is merged as complement of N⁰ (which, at least descriptively, corresponds to POSS₂) in both (362a) and (362c). The motivation for this stems from the apparent correlation between the presence of *hans* and the presence of DEF. Given his general assumptions discussed in section 5.3 above, examples (362) are analysed as follows:

- (363) a. [_{DP} [hús-ið]_k hans_i [_{POSSP} t_i [_{NP} t_k]]]
b. [_{DP} [hús-ið]_k hans_i [_{POSSP} Jóns_j t_i [_{NP} t_k t_j]]]
c. [_{DP} ... [_{NP} hús [_{DP} Jóns]]]

We have already seen, however, that *hans* actually occupies two different positions in (362b) and (362c), and that the sequence *hans Jóns* actually has the same distribution as the *DP-genitive Jóns*:

- (364) a. hús - in hans tvö
houses - DEF *hans* two
b. *hús - in tvö hans
c. hús - in tvö (hans) Jóns
houses - DEF two *hans* Jón.GEN
d. *hús - in hans tvö Jóns
e. *hús - in (hans) Jóns tvö

As (364a/b) show, when the head noun carries DEF, (postnominal) *pronominal possessives* precede numerals (i.e. occur in POSS₁), and as (364c) shows, *DP-genitives* follow numerals (i.e. occur in POSS₂). As indicated by the parentheses, it is of secondary importance whether *hans* is present or not (recall that it is not required in the dialectal pattern). (364d) shows that *hans* cannot occur in POSS₁ with a genitival name/kinship term occupying the low position. (NB: Delsing's analysis predicts this constellation to be generatable). Finally, (364e) shows that

DP-genitives either with or without a pronominal element cannot occur in POSS₁. These distributional facts clearly show that, in syntactic terms, *pronominal possessives* and the pronominal elements of *DP-genitives* are distinct. Moreover, the contrast between (364c/d) indicates that sequences like *hans Jóns* are indeed constituents.²⁹ I therefore consider it necessary that this distinction between the two uses of genitival pronominals be reflected in the glosses: “houses - DEF **his** two” for (364a) (= *pronominal possessive*) and “houses - DEF two [(**he**) Jón]-GEN” for (364c) (= *proprial article*).

In addition, it has also been argued against the view that the pronominal component of *DP-genitives* in examples like (361) is a *proprial article* (Delsing 1998), or denied that they are genitival elements in the first place (Julien 2005a). Claims of this kind are typically based on some potentially interesting data found in some Mainland Scandinavian dialects. I will illustrate one example from *Västerbotten Swedish* (taken from Delsing 1998:101):

- (365) galom hans farfarom
farm.the his grandfather.the.DAT

(365) supposedly shows that *hans* cannot “be the genitival form of the *proprial* pronoun, since the possessor *farfarom* is obviously in dative” (Delsing 1998:101) (which is moreover supposed to show that the two elements do not form a constituent). For Julien (2005a), this apparent case mismatch is not a problem, since she does not consider the pronominal element to bear genitive case to begin with (on her account, proper names and kinship terms in the constructions under considerations are complements of the pronominal, and thus do form a constituent).

It is important to bear in mind that, even though we find remnants of case marking in some Mainland Scandinavian dialects, by and large, Mainland Scandinavian languages/dialects have a strongly impoverished and close-to-non-existent case system. This goes not least for genitive case; Delsing (1991) argues that genitive as a lexical case was lost in Swedish in the fourteenth century. In this process, it became a structural case the assignment of which is dependent on D. As a consequence of this development, in Modern Swedish (and more general, in the Modern Mainland Scandinavian languages), the only extant morphological marker of genitive ‘s’ is – like the English *Saxon Genitive* – a clitic element which attaches to a noun phrase that is not otherwise morphologically case-marked. Icelandic, on

²⁹While Delsing (1998) cannot capture these facts, it seems as though Delsing (1993) can actually handle them, because in this analysis, *hans* in (362c) is analysed as the head of the *DP-genitive* (which in turn is the complement to N) – not as the head of POSSP:

(1) [_{DP} [hús-ið]_i [_{NP} t_i [_{DP} hans [_{NP} Jóns]]]] (Delsing 1993:169)

the other hand, possesses an active and functional case system, and all inflecting adnominal elements are themselves inflected for case, including the genitive, and agree in case with their head noun; compare:

- (366) a. [all.a dess.a tre berömd.a lingvist.er] -s (Sw.)
all.PL these.PL three famous.PL linguist.PL -“GEN”
b. all.ra þessa.ra þriggja fræg.u málfræðing.a (Icel.)
all.GEN.PL these.GEN.PL three.GEN famous.GEN.PL linguist.GEN.PL

Likewise, Icelandic systematically and transparently shows agreement also between pronominal and head noun (see also (359)/(360)):

- | | |
|---|--|
| (367) a. hann Guðmundur
[he Guðmundur]-NOM | (368) a. við bræður-nir
[we brothers-DEF]-NOM |
| b. hann Guðmund
[he Guðmundur]-ACC | b. okkur bræður-na
[we brothers-DEF]-ACC |
| c. honum Guðmundi
[he Guðmundur]-DAT | c. okkur bræðru-num
[we brothers-DEF]-DAT |
| d. hans Guðmundar
[he Guðmundur]-GEN | d. okkar bræðra-nna
[we brothers-DEF]-GEN |

In light of this transparency and regularity, it is difficult to construe the bold-printed elements in the *possessive construction* below but as pronominal and head noun agreeing in genitive case (cf. (367d) and (368d)):

- | | |
|--|---|
| (369) a. hús-ið hans Guðmundar
'Guðmundur's house' | b. hús-ið okkar bræðra-nna
'the house of us brothers' |
|--|---|

So whatever examples like (365) and others indicate, they should not be hastily used to make claims about the Icelandic case system or the Icelandic proprial article.

I will thus continue to assume that (i) sequences like *hans Jóns* are *DP-genitives* headed by a proprial article (where both proprial article and head noun are inflected for – and agree in – case); (ii) proprial article and head noun do form a constituent (which is reflected in the glossing); (iii) genitival proprial articles and homophone *pronominal possessives* are syntactically distinct elements.

As for (i), I will specifically assume that the proprial article is a head in the nominal fseq. Similar ideas have been proposed, for instance by Delsing (1993) for Scandinavian, cf. fn. 29, and by Panagiotidis (2002) more generally for cases like 'we linguists'; both authors assume that those pronominal elements occupy D⁰. Due to the existence of examples like (360a) and (368), however, illustrating that proprial article and DEF can, in principle, co-occur, and thus that the proprial

article cannot occupy *article*⁰, one D⁰ position is not sufficient. I propose that the proprial article occupies an X⁰ position in the D-layer above *article*P, cf. (69). Moreover, we have to assume that it places highly specific selectional restrictions on its complement. Finally, the proprial article must make some contribution that enables the merger of DEF and movement of *ix*P in the (colloquial) standard variety, which is otherwise blocked as we have seen above. I will not address these specifics here, and leave the issue to further research.

6.4 An Analysis of Poss₁

6.4.1 High Possessives

In section 5.2.4, cf. example (279), I proposed the following structure for POSS₁:

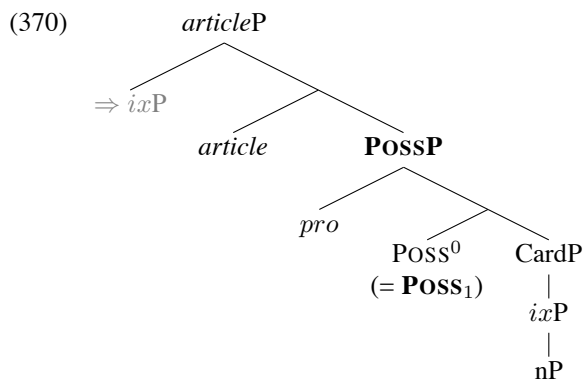

Thus, *pronominal possessives* merged in that position can easily be integrated into the structure developed in part I. They do not pose a problem for our assumptions about DEF and *ix*P movement or the strandability of *ix*P-external modifiers. Below, I give an example for illustration:

- (371) a. hestar - nir mínir þrír fræg.u
 horses - DEF my three famous.WK

contrast, in which case they must bear stress (Sigurðsson 1993, 2006; Julien 2005a; Thráinsson 2007):³¹

- (375) þetta er MÍN bók (ekki ÞÍN)
 this is MY book (not YOURS)

The *possessor* must be human; that is, contrast can be expressed this way only with respect to person or sex, but not with respect to grammatical gender: (376a) is fine if the *possessors* are male and female, respectively. But it is impossible, if both are male or both female, and the only distinctive feature is the gender of the noun referred to by the *possessor*. Neuter gender is not an option in the first place, cf. (376b):³²

- (376) a. HANS bók (ekki HENNAR bók)
 HIS book (not HER book)
^{ok}male vs. female
#masculine vs. feminine
 b. #ÞESS bók (ekki HANS bók)
 ITS book (not HIS book)

This echoes the discussion from section 6.2 where we saw that (postnominal) *pronominal possessives* occupying POSS₁ can only denote a [+HUMAN] *possessor*. The above observation suggests that this is a general property of POSS₁.

Apart from that, notice that prenominal *pronominal possessives* have some other interesting facets and properties that are not related to contrast. For instance, as soon as an adjective is added, it no longer needs to be contrastively stressed. The absence of contrastive stress on the *pronominal possessive* goes hand in hand with a systematic lack of restrictive interpretation of the adjective involved. In fact, we notice a strong parallel to pattern (II), both in structural terms and with respect to the adjectives that typically occur in this configuration:

³¹It should be noted that, while a prenominal possessive typically suggests contrast, the reverse does not hold, i.e. contrast does not necessarily entail a prenominal position for possessives. We do find constellations such as the following:

- (1) a. bíll - inn MINN (ekki ÞINN bíll) b. MINN bíll (ekki bíll - inn ÞINN)
 car - DEF MY (not YOUR car) MY car (not car - DEF your)

³²In Icelandic, natural and grammatical gender do not always coincide, and there are several neuter nouns in Icelandic that denote human beings. For instance, *kennari* 'teacher' is masculine, *hetja* 'hero' is feminine, and *skáld* 'poet' is neuter, but all three can refer to both men and women.

- (377) a. okkar litla fjölskylda
our little family
- b. mín óumræðilega fegurð
my undisputable beauty
- c. þín hetjulega barátta
your heroic battle
- d. þín langþráða hvíld
your long-awaited rest
- e. sín mikla sorg
POSS.REFL great sorrow
- f. minn fræg.i pastaréttur
my famous.WK pasta-dish
- g. mín meint.i krossferð
my alleged.WK crusade
- h. minn fullkomni.i dagur
my perfect.WK day

Also, as with pattern (II), we find that examples of this kind are often stylistically somewhat marked. Many of these typically occur in obituaries or poetic language.

Another crucial observation is that prenominal *pronominal possessives* cannot be argumental or have a thematic interpretation. They cannot be used with kinship terms³³ (Magnússon 1984:100; Thráinsson 2007:120/1), and they cannot denote a thematic argument of AS nouns, nor the “whole” argument of a part-whole noun:

- (378) a. #minn bróðir/faðir / #mín dóttir/móðir
my brother/father / my daughter/mother
- b. ↗ hans eyðilegging á borginni
his destruction on city.the
intended: ‘his destruction of the city (*possessor* = AGENT)’
- c. ↗ hennar eyðilegging
her destruction
intended: ‘its (= the city’s) destruction (*possessor* = THEME)’
- d. hans hluti
his part
ok ‘his part (of sth)’
‘part of it (= the inheritance)’

The badness of (378b-d) on the relevant reading is in line with what has been said about the corresponding examples involving a postnominal *pronominal possessive* in POSS₁, see section 6.2, and supports the following broad generalization: *pronominal possessives* in POSS₁ cannot denote thematic arguments of the head noun. However, we know that kinship terms are more liberal than part-whole nouns

³³For some reason, the unacceptability illustrated in (378a) seems to be mitigated in the presence of an adjective and/or when used as a vocative:

- (1) a. minn kæri vinur / bróðir
my dear friend / brother
- b. mín elskulega vinkona / systir
my lovable friend / sister

and eventive AS nouns, and do occur (postnominally) in $POSS_1$, therefore (378a) is somewhat unexpected; I will propose a solution to this conundrum below.

Note that examples like (378a) are not bad per se, but merely on the IPR reading that entails that the speaker is x's sibling/child/parent. They are fine on a GPR reading where the relationship is not lexically determined, but external, and contextually determined: Imagine a contest where ten man-woman pairs are competing. Now it so happens that all the men are linguists and all the women have at least one child (and are thus mothers). Suppose A and B are a pair in this contest; presenting themselves to the other participants, they may felicitously say:

- (379) a. Hann er MINN málfræðingur ...
 He is MY linguist ...
- b. B: ... og hún er MÍN móðir
 ... and she is MY mother
 → [mother(A) & GPR(A, B)]

Crucially, (379b) does not entail that B is A's son; the head noun 'mother' is interpreted as a common noun rather than relational (NOT: IPR(A, B)). This is reminiscent of examples like (320) where the presence vs. absence of DEF determined whether a kinship term receives a GPR or an IPR interpretation.³⁴

Prenominal *pronominal possessives*³⁵ have more interesting semantic properties, and there is certainly a lot work to be done yet, but I will not go further. I will not consider some apparently obvious aspects such as contrast, cf. (375), (376), and (379), either. It seems inviting to construe contrastively used prenominal GENITIVALS as resulting from a focus-driven movement to the nominal left periphery. For instance, considering examples such as the ones in (380), (Julien

³⁴The difference seems to be that cases like (379) additionally suggest a contrastive or, at least, an emphatic reading with respect to the *possessor*.

³⁵Non-pronominal GENITIVALS in prenominal position (where possible) have the same properties as pronominal ones: they typically express contrast (1a), or may be used in "poetic language" (Sigurðsson 2006:211; see also Magnússon 1984:103), cf. (1b), and they cannot be argumental (1c/d):

- (1) a. JÓNS bók (ekki mín bók)
 Jón.GEN book (not my book)
- b. Íslands fögr.u fjöll (Sigurðsson 2006:211)
 Iceland.GEN beautiful.WK mountains
- c. *Sesars eyðilegging á borginni
 Cesar.GEN destruction on city.the
- d. *borgarinnar eyðilegging
 city.the.GEN destruction

Recall further that prenominal GENITIVALS can only have a GPR reading, but not an IPR reading, cf. (378)/(379). I propose that they start out with the denotation given in (382a), and that, analogously to (382b/c), they may raise to *article*⁰ and thus shift to a determiner type:

$$(383) \quad \llbracket [_{\text{article}^0} \text{POSSESSIVE}_{\text{GPR}}] \rrbracket = \lambda P. \iota z. P(z) \ \& \ R(\text{possessor})(z) \quad \text{GPR-determiner}$$

Since this variant does *not* carry [**ix**], it does not trigger *ixP* movement and thus *ixP* remains in its base position rendering the *pronominal possessive* prenominal. Below I give the trees for (374a) and (377f):

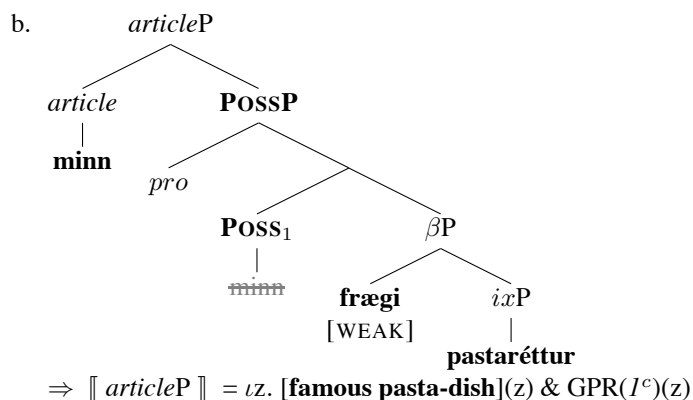
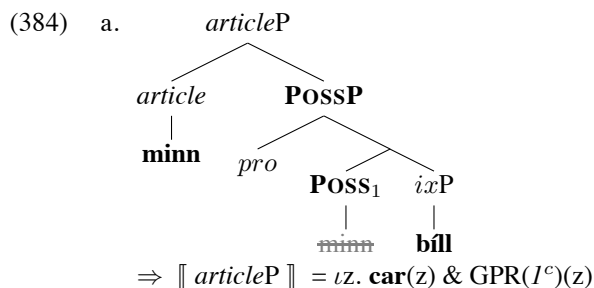

Thus with the assumptions of (i) two variants of *pronominal possessives* occurring in *POSS*₁ only one of which carries the feature [**ix**], and (ii) (potential) movement to *article*⁰, we have a simple and systematic account of all possible constellations involving *POSS*₁. In particular, the intuition that prenominal GENITIVALS behave like definite determiners receives a natural explanation.

The keyword *definite determiner* leads to an issue omitted so far, namely the licensing of weak inflection. DEF carries the feature [DEFINITE] that – when c-commanding the adjective – triggers the weak inflection. In section 6.1, I suggested that GENITIVALS (in *POSS*₁) also carry that feature. But if that is the case, the

question arises which feature actually triggers the weak inflection if there are two instances. Consider the following example:

- (385) *bíll - inn minn frægi*
 car - DEF my famous.WK

If both DEF and the *pronominal possessive* carry [DEFINITE], there are prima facie two conceivable scenarios. Either both trigger weak inflection simultaneously, cf. (386a), or only the lower one on the possessive actually triggers weak inflection on the c-commanded adjective, while it simply concords with the higher one, cf. (386b):

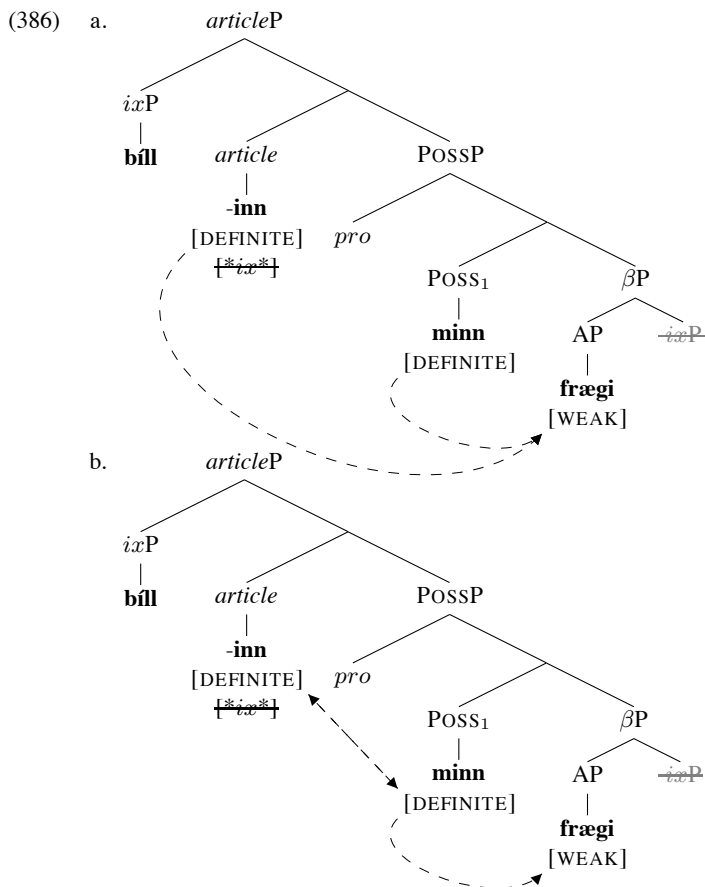

Alternatively, we could assume that it is really only the feature on DEF that triggers weak inflection while the one on the *pronominal possessive* is inert:

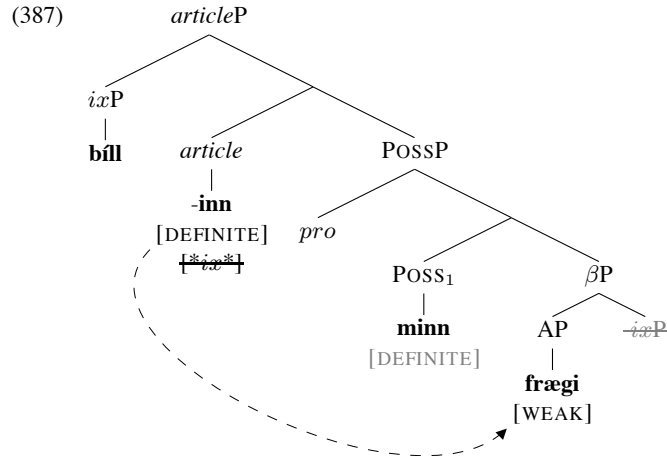

I argued above that the IPR variant of *pronominal possessives* carries the feature $[*ix*]$, which is only interpretable in $article^0$, not in $POSS_1$. So we could simply assume that the same goes for the feature $[DEFINITE]$. As far as I can tell, all three versions lead to desired outcome for the examples under consideration. For the sake of simplicity, I will stick with the one sketched in (387).

With this in place, let us have a look at a case not involving DEF:

(388) bróðir minn frægi
brother my famous.WK

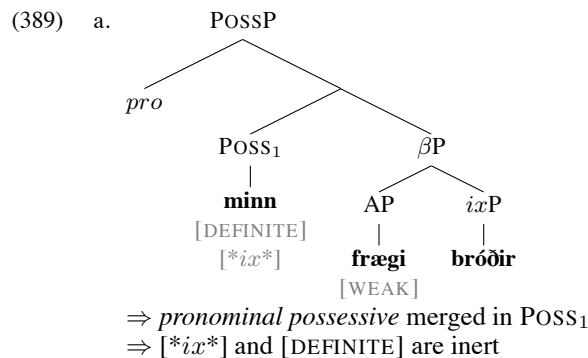

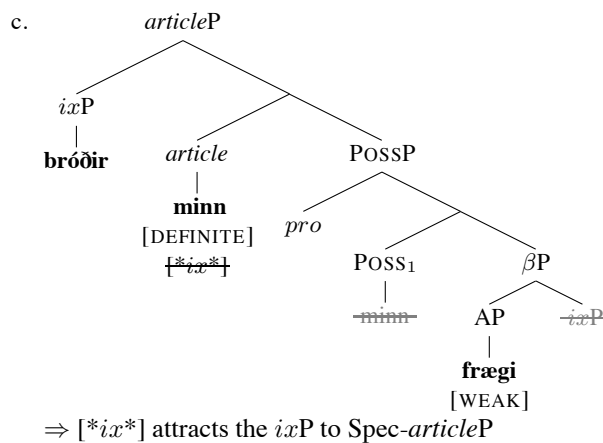
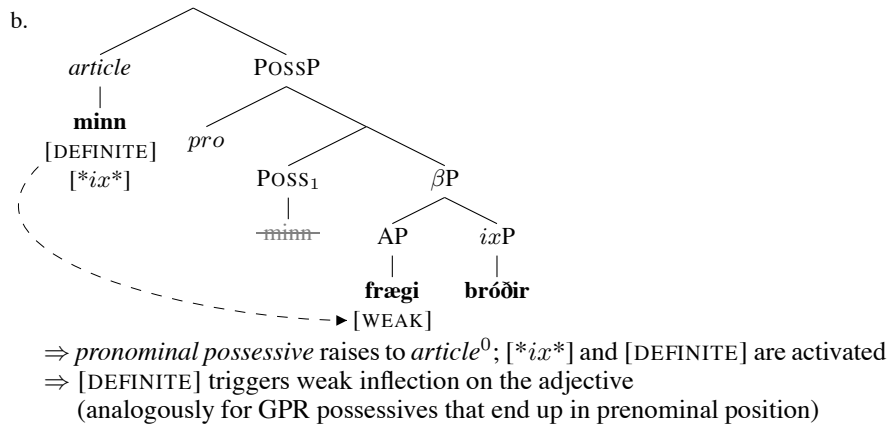

Thus with a rather small set of assumptions, we have provided a unified account for all *pronominal possessives* occurring in POSS₁.³⁶ The relevant constellations are repeated below:

- (390) a. *ixP* -DEF POSS ~~*ixP*~~ GPR modifier
 b. *ixP* POSS ~~*ixP*~~ IPR determiner
 c. POSS *ixP* GPR determiner

One crucial feature of this account is the assumption that those *possessives* come in two flavours, GPR and IPR. The latter necessarily moves to *article*⁰ whence it triggers *ixP* movement to Spec-*articleP*, and in the process, shifts to a determiner type. The GPR variant, on the other hand, either remains in POSS₁ where

³⁶Except perhaps for the cases involving contrastive focus which I suggest require a somewhat different treatment.

it co-occurs with DEF and is interpreted as possessive modifier, or it also moves to *article*⁰ and shifts to a determiner type. However, since it does not carry [**ix**], it does not trigger *ixP* movement, and thus it surfaces preminally.

Moreover, the high position can straightforwardly be integrated into the noun phrase structure as developed in chapter 4:

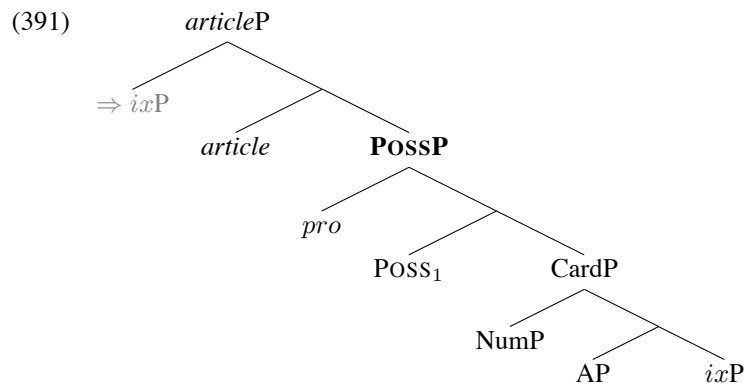

The addition of POSS₁ is fully compatible with our previous assumptions about *ixP* movement and the stranding of *ixP*-external modifiers. We will see in the next chapter that this not as straightforwardly the case with POSS₂.

6.5 APPENDIX – Variation: “Definite” Adjectives?

(Sigurðsson 2006:200, fn.3) notes that “definite NPs with a definiteness marking of only the adjective [= weak inflection] are sometimes heard in colloquial Icelandic (**where it seems to be gaining ground**)” (emphasis mine, A.P.), and gives the following example:

- (392) nýja plata Bjarkar
 new.WK record Björk.GEN
 ‘Björk’s new record’

The existence of such examples blatantly contradicts the generalizations on the distribution of adjectival inflection. But as the quotation makes clear, examples like (392) are best to be treated as an innovation, as an indicator of a language change.

In the following, I will merely give a tentative overview of some relevant aspects. The following examples are taken from my survey, including the judgments which are based on the average scores given by the participants (see section 1.4):

- (393) a. ✎ algjör.a eyðilegging Sesars á borginni
 total.WK destruction Cesar.GEN on city.the
 b. hin algjör.a eyðilegging Sesars á borginni
 ART total.WK destruction Cesar.GEN on city.the
 c. algjör eyðilegging Sesars á borginni
 total.STR destruction Cesar.GEN on city.the
 ‘Cesar’s total destruction of the city’
- (394) a. ??nýj.a kenning Darwins (um uppruna dýrategunda)
 new.WK theory Darwin.GEN (on origin of.species)
 b. hin nýj.a kenning Darwins (um uppruna dýrategunda)
 ART new.WK theory Darwin.GEN (on origin of.species)
 c. ný kenning Darwins (um uppruna dýrategunda)
 new.STR theory Darwin.GEN (on origin of.species)
- (395) a. ??illskeytt.i guð gamla testamentisins
 ill-tempered.WK god [old testament]-GEN
 b. hinn illskeytt.i guð gamla testamentisins
 ART ill-tempered.WK god [old testament]-GEN
 c. illskeytt.ur guð gamla testamentisins
 ill-tempered.STR god [old testament]-GEN

The average scores for the b- and c-examples range above 2.00 (*fine*), which is in complete agreement with the generalizations as stated so far: with a c-commanding

trigger present (here: ART), the adjective is weakly inflected, with no trigger present, it is strongly inflected. On the other hand, the average scores for the a-examples, which display bare weak inflection, are below 1.5 (*very marginal*). With adjectives modifying deverbal AS nouns, this contrast is particularly strong: bare weak inflection is categorically judged *bad*, i.e. below 1.0, cf. (393a). But even those cases where bare weak adjectives are “merely” judged *very marginal*, cf. (394a) and (395a), are an indication that, as a rule, bare weakly inflected adjectives are considered bad.

Just for the sake of illustration, we can go two (tentative) steps further in order to get a more differentiated picture and look at the average scores of two age groups separately (the numbers in square brackets indicate the number of participants in the respective questionnaire/age group):

⇒ A.WK N DP.GEN	X - 40 years	41 - X years	general
(394a)	1.79 (?) [7]	0.93 (↘) [14]	1.21 (??) [21]
(395a)	1.89 (?) [9]	0.87 (↘) [16]	1.24 (??) [25]

Table 6.1: Scores Adjectival Inflection: General

The pure numerical difference in scores between the two groups is staggering. We see a much greater tendency to accept bare weak inflection amongst younger speakers (*slightly marginal*) as opposed to the older speakers who reject it (*bad*). This same pattern shows up in many other comparable cases tested in my survey, and in interviews with native speakers of different age groups. In this sense, this impressionistic overview corroborates Sigurðsson’s claim that bare weak inflection is “gaining ground”.

But as the contrast (393a) vs. (394a)/(395a) suggests,³⁷ this is not simply a linear development. In addition, it should be noted that even speakers who accept bare weak inflection in certain cases tend to judge the alternatives (ART + A.WK or A.STR) better. Pending a more detailed empirical study into the variation of adjectival inflection in *possessive constructions* and a more fine-grained statistical evaluation, and conceding that a split into the age groups ‘40 and younger’ vs. ‘41 and older’ may seem a bit arbitrary – I nonetheless conclude that, at a coarse level we have to distinguish between (at least) two varieties (or dialects). Abstractly, we are talking about the two ends of a spectrum. On the one hand, we have the conservative variety, which conforms to the hypothesis that weak inflection always needs to be licensed/triggered, that bare weak inflection is illicit, and that weak inflection is a mere agreement marker. On the other hand, there is a progressive variety where bare weak inflection seems to be gaining ground, that is, weakly inflected

³⁷NB: even young speakers reject bare weak inflection in examples like (393a).

adjectives occurring in *possessive constructions* seemingly without a trigger, i.e. an overt c-commanding morpheme carrying the feature [DEFINITE].

In this connection, it should be noted that the scores reported for (394) are actually the arithmetic mean of the scores of two different tasks (on the same questionnaire; same participants), and can be further dissected. On one case, participants were asked to judge a range of versions of *Darwin’s new theory* in a neutral setting: “_____ attracted a lot of attention”, in the other case, in a contrastive setting: “_____ was much more popular than his old theory”. The scores are given below:

		(394a) nýja kenning Darwins (bare) WEAK	(394c) ný kenning Darwins STRONG
neutral	general	1.00	2.67
	? - 40	1.43	2.71
	41 - ?	0.79	2.64
contrast	general	1.43	2.19
	? - 40	2.14	1.86
	41 - ?	1.07	2.36

Table 6.2: *Scores Adjectival Inflection: Neutral - Contrastive*

Looking at the broad picture, we find that, regardless of context,

- strong inflection is generally preferred over (bare) weak inflection,
- strong inflection is generally *fine*,
- (bare) weak inflection is generally *very marginal* or *bad*.

For the older age group, the scores differ minimally in the two scenarios: (bare) weak inflection is somewhat better in the contrastive scenario (+0.28), and strong inflection is somewhat less good in the contrastive scenario than in the neutral one (-0.28). But the scores comply with the overall generalizations. For the younger age group, on the other hand, the scores differ drastically in the two scenarios:

- in the contrastive scenario, weak inflection is judged better than strong inflection
- in the neutral scenario, strong inflection is *fine*, in the contrastive scenario, it is *marginal* (-0.85),

- in the neutral scenario, weak inflection is *very marginal*, in the contrastive scenario it is *fine* (+0.71).

In light of my assumptions that (i) weak inflection needs to be triggered/licensed, and (ii) adjectival inflection does not itself make a semantic contribution, these preliminary findings can be taken to indicate that the conditions on licensing are becoming increasingly weaker, and that weak inflection is more and more used to express semantic content (perhaps [DEFINITE] itself, or some feature [IDENTITY] as Lohrmann 2008, 2010 suggests). At any rate, it seems as though the progressive variety lends support to the analyses put forward by Julien (2005a) and Lohrmann (2008, 2010); recall that, on Julien's account, weak inflection is not "a 'dummy' inflection without semantic content" (Julien 2005a:44). Alternatively, it could indicate the emergence of a zero article \emptyset carrying the feature [DEFINITE] that is merged in *article*⁰.

I will not speculate further; what I call the progressive variety clearly must be investigated in more detail in order to establish useful generalizations. The empirical generalization that weak inflection is triggered by a c-commanding morpheme carrying [DEFINITE] remains valid in the absolute majority of the cases. If we admit covert licensors (which will presumably be needed for vocatives anyway), even the progressive variety is not necessarily a big challenge. What remains completely uncontested is the idea strongly defended in this thesis that, if weak inflection is not triggered, the adjective inflects strongly; strong inflection itself is not triggered and does not add any semantic content (indefiniteness or other).

Chapter 7

The Genitive's Problem

In this chapter, I will show that *possessive constructions* involving the low position POSS_2 in conjunction with the phenomenon I labeled *genitive stranding* pose a problem, and cannot be analysed as matters now stand. In section 7.2, I will introduce an analysis developed in Adger (2013) that allows a novel treatment of the structural relation between head noun and GENITIVAL. I will adopt some central aspects of that proposal and integrate it into the system developed so far. This modification not only provides an elegant solution to the problem posed by stranded genitives, it moreover opens a new perspective for the analysis of genitival modification at large.

7.1 Low GENITIVALS and Stranded Genitives

For GENITIVALS occupying POSS_2 , I have not yet given a precise structure, the reason for which will become clear in this subsection. As a point of departure, let us adopt the following structure:

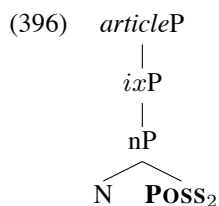

This is rather similar to Delsing's (1993, 1998) proposal who suggests that *DP-genitives* and possessive PPs – but not *pronominal possessives* – are merged as complement to N^0 . The difference here is that I assume that *pronominal possessives* also occur in POSS_2 . Let us now look at a number of representative examples:

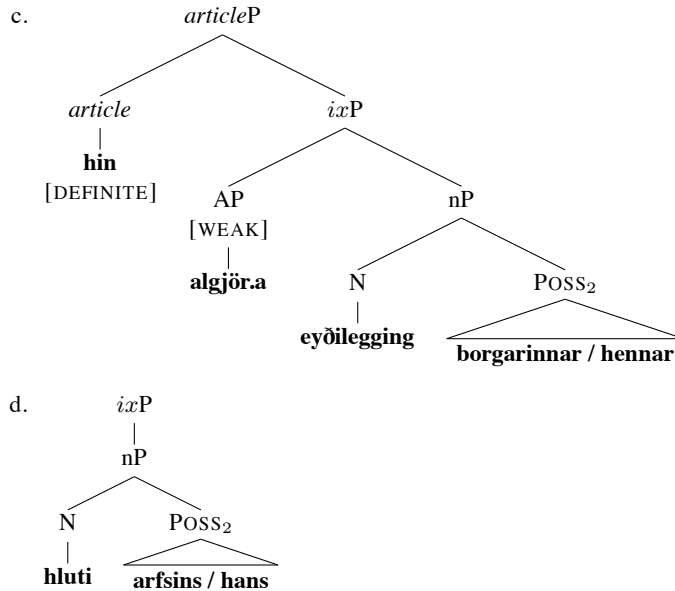

For examples like these, the structure given in (396) is absolutely sufficient. We can directly generate all the orderings observed when the head noun (*ixP*) remains in its base position: (DET >>) NUM >> ADJ >> N >> POSS₂. In particular, we do not expect to generate structures with postnominal (numerical or adjectival) modifiers.¹ Likewise we have a straightforward account of adjectival inflection: GENITIVALS in POSS₂ cannot license the weak inflection on adjectives because – even if they carry the feature [DEFINITE] – they do not c-command them. Therefore the adjective occurs strongly inflected, cf. (399a/b), unless a morpheme carrying that feature is merged in a higher c-commanding position, cf. (399c).

One issue does seem to arise, though: what prevents DEF from being merged? The specific problem here is the feature [**ix**] it carries, which triggers movement of *ixP*. In the structures under discussion, POSS₂ is the complement to N⁰ and thus an element of NP and thus a subconstituent of *ixP*. If *ixP* moves, we predict it to move along, which is, however, ungrammatical:

¹Such as the following:

- (1) a. *bræður þrír málfræðingsins/ hennar
 brothers three linguist.the.GEN/ her
 b. *eyðilegging borgarinnar/ hennar algjör.a
 destruction city.the.GEN/ her total.WK

- (400) a. *hattur kennarans - inn
 hat teacher.the.GEN - DEF
 b. * $[articleP [ixP hattur kennarans] - inn \quad \cancel{ixP}]$

So we have to find another way to rule out the possibility of head noun + GENITIVAL moving as a constituent. For the time being, I stipulate that certain complex *ixPs*, namely those whose head noun have a complement, are immobile and cannot move. Thus, in case DEF, carrying the feature $[*ix*]$, is merged above an immobile *ixP*, it fails to attract the latter:

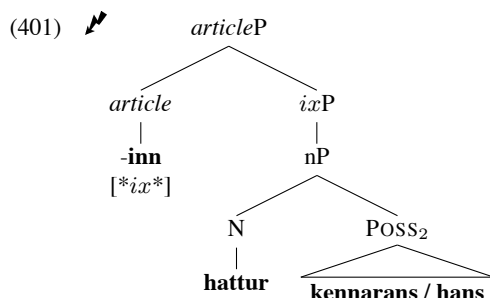

As a result, $[*ix*]$ cannot be checked, and the derivation crashes (a suffix is stranded without a host). I will motivate this move better in the next section. At any rate, there seems to be a viable solution for the problematic structure in (400).

But this leads to an even more serious problem stemming from the phenomenon of genitive stranding discussed in section 6.3. According to all criteria we have applied so far (notably, the head noun carries DEF and precedes stranded numeral and adjectival modifiers), these cases must be assumed to involve *ixP* movement – while the GENITIVAL gets stranded in $POSS_2$ (thus following postnominal numeral and adjectival modifiers):

- (402) a. guli bíll - inn %*(hans)* Jóns
 yellow car - DEF [he Jón]-GEN
 b. hestar - nír þrír frægu hans afa
 horses - DEF three famous [he grandfather]-GEN

What is so problematic here is the status of $POSS_2$ as complement of N^0 as proposed in structure (396) above. If the GENITIVAL is to be stranded in the low position, the only way to extract the head noun permitted by (396) is via movement of bare N^0 . However, I have decidedly argued against head movement and strongly in favour of phrasal movement when it comes to the operation resulting in N-DEF; as a matter of fact, I take it that (402a) clearly shows that the moved constituent

is phrasal: [AP nP]. Thus head movement (of N^0) is fundamentally incompatible with my analysis. More specifically, I have argued that not only is movement phrasal, it is categorically of *ixP*. But as we have just seen, *ixP* cannot move without dragging the GENITIVAL along, which is why I posited that complex *ixPs* are immobile. Furthermore, since I am dispensing with pure word order movement including evacuation and remnant movement, I cannot resort to alternatives building on “rescue” structures such as the following:

(403) -inn ... [_{XP} [hans Jóns]₁ [_{ixP} guli bill t₁]]

The trees below illustrate the dilemma:

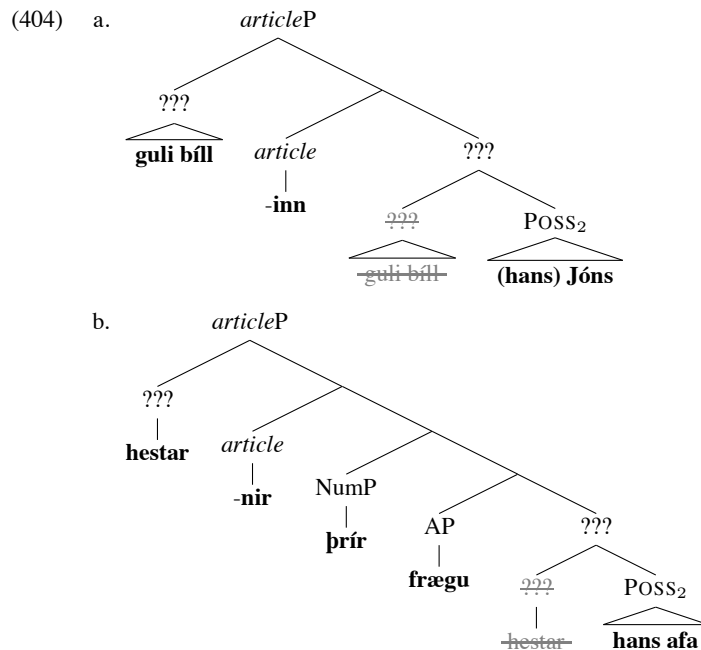

In other words, as it stands, we have no means to analyse examples like (402) involving genitive stranding in a way that correctly captures the data and is in agreement with the core tenets of the analysis developed so far. At the very least, we have to dismiss (396) as unsuitable.

In the next section, based on a novel analysis of relational nouns proposed by Adger (2013), I will develop a solution to this conundrum. I will show that we actually can handle all those problematic cases by only relying on *ixP* movement, without resorting to word order movement.

7.2 POSS₂ Revisited

The last section ended with a paradoxical situation: we do not seem to be able to analyse GENITIVALS that are stranded in the low position POSS₂; the problematic structure is repeated below:

- (405) a. hestar - nir þrír frægu ~~hestar~~ hans pabba
 horses - DEF three famous [he dad]-GEN

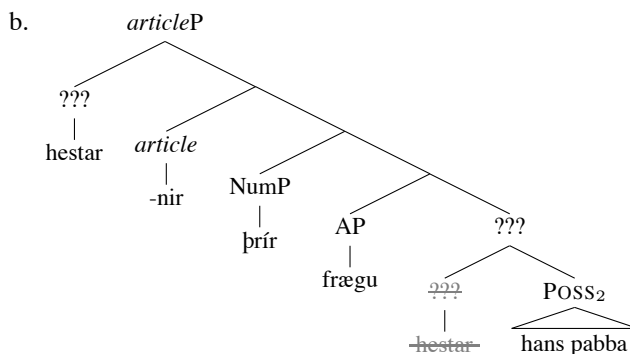

The problem this structure poses has two components: phrase-structural status of the nominal, and containment of POSS₂. I have argued at length that N-DEF sequences involve phrasal movement of some nominal projection, namely *ixP*, but the nominal *hestar* in (405b) appears to be a head ($\rightarrow ??? = N^0$). Since the GENITIVAL in POSS₂ is construed as a complement to N, the minimal phrasal constituent that contains the noun (= NP, and by extension, every higher projection) also contains POSS₂. Thus the assumption of phrasal movement entails that POSS₂ moves along. But we know the contrary to be the case, POSS₂ does not move along – it gets stranded.

I have already dismissed an approach to the problem that involves extraction of the GENITIVAL followed by remnant movement of *ixP*, or other kinds of word order movement. An alternative approach builds upon the assumption that the GENITIVAL is not a part of *ixP* in the first place. In the following, I will explore an analysis along these latter lines.

7.2.1 SoS – Two Nominal Fseqs (Adger 2013)

In “A Syntax of Substance” (henceforth “SoS”), Adger (2013) proposes an analysis of relational nouns that breaks radically with a number of traditional ideas. The main driving force behind this proposal are certain conceptual and theory-internal issues resulting from Chomsky’s Bare Phrase Structure approach (Chomsky 1995). Adger aims at “[developing] a syntactic system that entirely separates structure

building from the labeling of structure” (op.cit.:1). I will not address all the theoretical issues in detail here, but instead focus on the consequences for the analysis of GENITIVALS.

One central element of SoS is the assumption that roots do not have a category, and they can only enter the syntactic computation through Self Merge. Self Merge, in turn, yields a syntactic object that can be labeled such that “that label can be any category that can start an extended projection” (op.cit.:1). Since syntactic roots are only subject to Self Merge, it follows that it is not possible to merge a root with any syntactic object distinct from that root. This is important because it entails that root-argument relations are not local; relevantly, it means that nouns themselves do not actually take arguments.

Indeed, Adger (2013) argues that there are no genuine relational nouns (= two-place predicates), but only common nouns (= one-place predicates), thus nullifying traditionally perceived distinctions between nouns like e.g. ‘part (of)’ and ‘cat’. On his account, relationality between a noun and its alleged argument is negotiated in the syntax, and essentially re-construed as *Predicate Modification*. The “negotiator” here is a light root \mathfrak{p} which encodes relational semantics and controls the case marking/choice of preposition on the “argument”. Adger assumes that there is a very small number of such roots that “give lexical content to the two-place relation \mathfrak{p} introduces” (op.cit.:78), such as \sqrt{PART} (part-whole relations), \sqrt{REP} (representations), \sqrt{KIN} (kinship), \sqrt{POSS} (possession).² The general phrase structural format of “relational nouns” / AS-nominals is given in (406) below:³

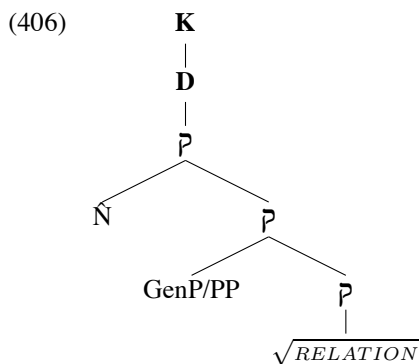

To see more concretely how this analysis works, and where it deviates from

²Adger (2013) touches only briefly upon the subject of complex event (=AS) nominals, but proposes that there may be a \mathfrak{p} -root like \sqrt{THEME} that introduces the THEME argument in examples like ‘examination of the students’.

³ \hat{N} is some extended nominal projection containing not only the noun, but also certain adjectives and numerals; see below. $\sqrt{RELATION}$ is a placeholder for one of the more specific relations just enumerated.

aspect of this analysis, that the constituent that is supposed to form the core of the “noun” phrase – the “head noun” – should appear as a peripheral specifier.

On the other hand, it is exactly the assumption that some nominal projection and the GENITIVAL are two distinct phrasal constituents within some \mathfrak{P} projection that helps solve the dilemma we faced above. Thus if we identify ixP with \hat{N} , i.e. as the second specifier of \mathfrak{P} , and POSS₂ as the first specifier of \mathfrak{P} , we obtain the following structure:

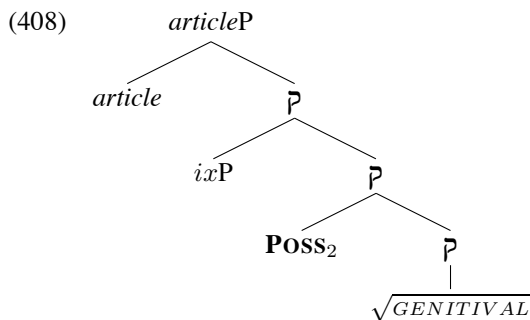

ixP and POSS₂ are both independent phrasal constituents (specifiers) that do not form a constituent. Given this structure, it follows without further stipulations or operations like word order (i.e. evacuation, remnant or roll-up) movement that the GENITIVAL can be stranded while ixP moves to Spec-*articleP*:

- (409) a. guli bÍll - inn hans pabba
yellow car - DEF [he dad]-GEN

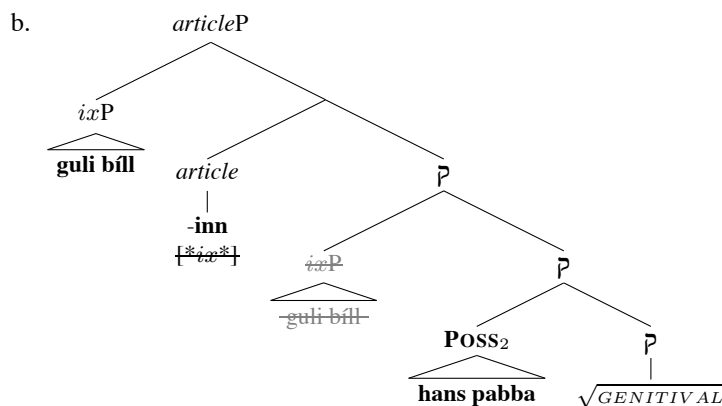

Adger moreover assumes that, apart from the head noun itself, \hat{N} contains intersective adjectives and numerals. The central argument for this assumption, which is also one of the most important empirical concerns of SoS stems from *PP-Peripherality*, the observation that PPs are always further away from the noun

than adjectives.⁴ But here the Icelandic data – namely, pattern (III) modifiers like numerals and certain adjectives – pose a problem. First of all, I have argued at length that they are precisely not part of the moved nominal constituent *ixP*, but are merged higher, i.e. outside *ixP*. Upon movement of *ixP* to Spec-*articleP*, they get stranded in postnominal position. Therefore, Adger's \hat{N} cannot be identical to my *ixP*. But in addition, we must assume, contra Adger (2013), that numerals and pattern (III) adjectives are, in fact, merged outside \mathfrak{P} . The reason is this: Adger's \hat{N} is an extended nominal projection that includes numeral modifiers, thus it roughly corresponds to CardP, and thus it must be assumed to properly contain *ixP* (and *ixP*-external adjectives) as a sub-constituent(s):

$$(410) \quad [_{\hat{N}/CardP} NumP [\beta P AP [ixP AP nP]]]$$

Now let us have a look at the following scenario: (411a) shows an example involving postnominal modifiers, which, on the present account are assumed to be stranded by *ixP* movement, and thus must be merged outside *ixP*. In (411b), I sketch an analysis that implements Adger's conception (i.e. $\hat{N} \sim CardP$). In (411c), I give an alternative analysis where \hat{N} is replaced by *ixP*:

- (411) a. hestar - nir þrír frægu hans afa
 horses - DEF three famous [he grand-dad]-GEN

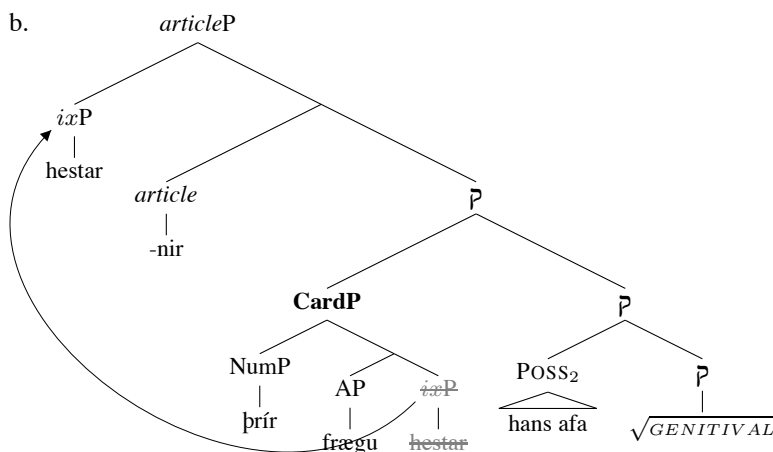

⁴(Adger 2013:7) formulates this typological generalization as follows:

(1) *PP-Peripherality*

When (intersective) AP modifiers and PP “complements” both occur to one side of N inside a noun phrase, the PP is separated from the N by the AP.

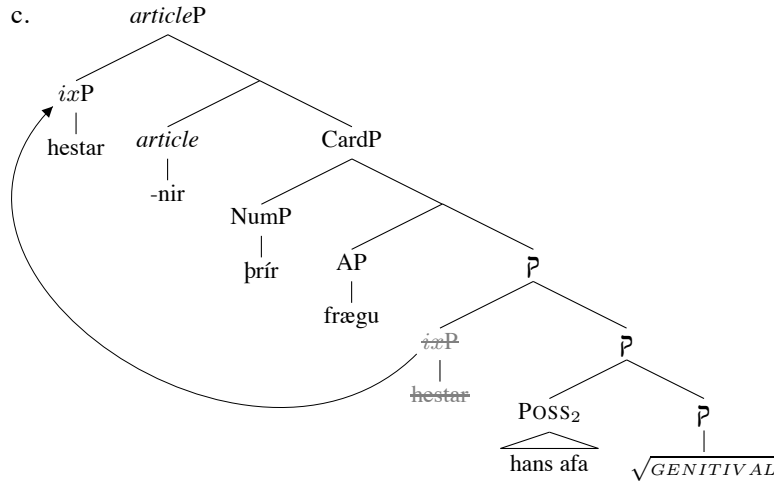

The difference is obviously the following: in (411b), in order to move to Spec-*articleP*, *ixP* has to move out of *CardP*, which itself occupies a specifier position. It has long been noted that extraction out of a specifier is heavily restricted. Thus it seems a priori undesirable to postulate a structure that systematically relies on that operation as long as there is an alternative that avoids that problem. In (411c), the problem does not arise. Pattern (III) elements, i.e. *ixP* external modifiers that get stranded, are assumed to be merged outside $\bar{\mathcal{P}}$, and movement of *ixP* does not involve extraction (out of the specifier) to begin with. Rather it instantiates Spec-to-Spec raising. So to the extent that I adopt Adger's analysis of relationality, I will adhere to the modified structure in (411c).

Adger's treatment of "relational" nouns and genitival/PP "arguments" of nouns provides an interesting and genuine solution to the problem of genitive stranding without resorting to word-order driven movement operations. But the question is whether (408) is the general structure for all noun phrases involving GENITIVALS/POSS₂. In the next subsection, I will address some concerns.

7.2.2 Challenges for SoS

The structure of a nominal extended projection based on $\bar{\mathcal{P}}$ as a start category raises an important issue already alluded to above: the constituent that is normally thought to form the core of the nominal fseq, namely some nominal projection containing the actual noun/NP, occurs in a specifier. On this conception, *articleP* (or DP/KP) is not an extended projection of N, but of $\bar{\mathcal{P}}$. This, in turn, raises the question what happens in the case of unpossessed nouns, i.e. common nouns without any accompanying GENITIVAL (or PP). After all, $\bar{\mathcal{P}}$ was designed to account for those putative arguments (or companions) of nouns. So, should a N-DEF sequence

such as *hestur-inn* in the following example receive a different analysis depending on the presence/absence of a GENITIVAL?

- (412) a. *hestur - inn frægi*
 horse - DEF famous
 b. *hestur - inn frægi hans pabba*
 horse - DEF famous [he dad]-GEN

On the analysis of pattern (III) noun phrases as developed in chapter 4, examples such as (412a) involve movement of *ixP* from a complement position to Spec-*articleP*, cf. (413a). For examples involving a stranded GENITIVAL such as (412b), on the other hand, I proposed adopting Adger's \bar{P} -structure in the previous subsection, which entails Spec-to-Spec movement, cf. (413b):

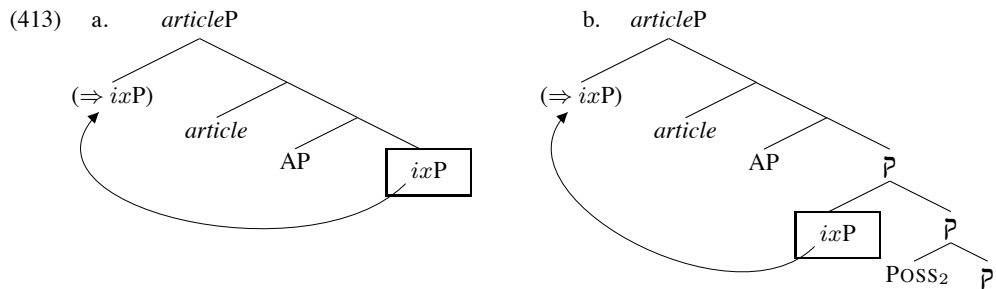

The obvious difference between the two lies in the X-bar theoretic status of *ixP* (complement vs. specifier). Adger (2013) himself opts for uniformity. For common noun phrases not involving GENITIVALS (or PPs), he proposes “an intransitive \bar{P} whose content is identified by light roots with very general meanings (eg. \sqrt{THING})” (SoS:168). This means that \bar{P} is categorically construed as the start category of the main projection line of the nominal fseq, whereas the nominal core projection containing the noun (i.e. *ixP*) is construed as specifier of some \bar{P} across the board, cf. (414a). An analysis of (412a) implementing this idea is sketched in (414b):

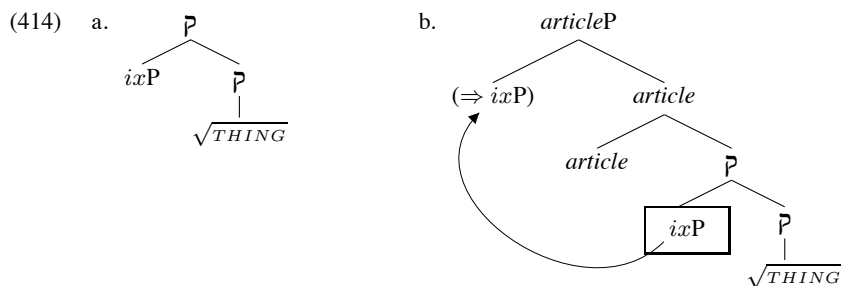

While the prospect of uniformity is certainly appealing, I will not adopt this idea, but stick with (413a) for noun phrases not involving POSS₂, see 7.3 below.

A potential problem lies in Adger's abolition of relational nouns. Recall that, on his account, all nouns/nominal projections are treated as common nouns (i.e. simple predicates of type $\langle e,t \rangle$); relationality is entirely negotiated by some \mathfrak{p} -root and effectively treated as (predicate) modification. As a consequence, certain distinctions traditionally made between relations cannot be represented structurally. Even the rather broad distinction between "possessive" and "argumental" GENITIVALS, which largely correlates and coincides with the distinction between common and relational head nouns, for which distinction I introduced the labels GPR vs. IPR, appears only as a difference between \mathfrak{p} roots (\sqrt{POSS} vs. \sqrt{KIN} , \sqrt{PART} , \sqrt{THEME} ...).

The empirical problem that motivated adopting Adger's \mathfrak{p} -analysis for Icelandic in the first place is posed by constellations like (415a), with DEF on the head noun, which involve raising of *ixP* and stranding the GENITIVAL. Those cases constitute a (relatively) clearly definable exception. As was shown in section 6.3, if (a) the *possessor* is [+HUMAN] and (b) the possessive relation is a GPR, then DEF may occur on the head noun (i) in certain dialects, or (ii) if the *possessor* is denoted by a proper name or kinship term which is preceded by a proprial article in the (colloquial) standard variety. On the other hand, if the relation between head noun and GENITIVAL is to be construed as IPR, the ("relational" or eventive AS) head noun cannot carry DEF even though the GENITIVAL is of the "right kind":

- (415) a. bíll - inn hans pabba
car - DEF [he dad]-GEN
- b. bróðir (*-inn) hans pabba
brother -DEF [he dad]-GEN
- c. eyðilegging (*-in) hans pabba á borginni
destruction -DEF [he dad]-GEN on city.the → *possessor* = AGENT
- d. eyðilegging (*-in) hans pabba
destruction -DEF [he dad]-GEN → *possessor* = THEME

This is a fortiori so in those cases where the *possessor* is [-HUMAN] and the relation cannot plausibly be construed as GPR:

- (416) a. eyðilegging (*-in) Rómar
destruction -DEF Rome.GEN
- b. horn (*-ið) stofunnar
corner -DEF room.the.GEN
- c. eldur (*-inn) ástarinnar
fire -DEF love.the.GEN
- d. stærð (*-in) hússins
size -DEF house.the.GEN

and a GENITIVAL.⁷ Indeed, this aspect of Adger’s analysis, I would like to retain. In addition, however, I would like to implement a structural distinction to the effect that \mathfrak{N} can be interspersed at different projection heights in the nominal fseq; assume that \mathfrak{N} itself does not have a categorial feature and thus no fixed position in the fseq. Instead I propose that it inherits/assumes the categorial status C^n of the constituent in its specifier (via Spec-Head agreement), and is itself embedded under some category C^{n+i} (with $i \geq 1$). Thus \mathfrak{N} can be said to instantiate *same category recursion*. Assume for the present purpose two relevant nominal categories occurring in Spec- \mathfrak{N} : nP and *ixP*. In the former case, $CAT(\mathfrak{N}) = \text{nP}$, and \mathfrak{N} is embedded under a category that is higher than nP in the nominal fseq, namely *ix*. In the latter case, $CAT(\mathfrak{N}) = \text{ixP}$, and \mathfrak{N} is embedded under a category that is higher than *ixP*, such as Card or *article*. I will refer to the former case as nP-level \mathfrak{N} , and to the latter as *ixP*-level \mathfrak{N} :

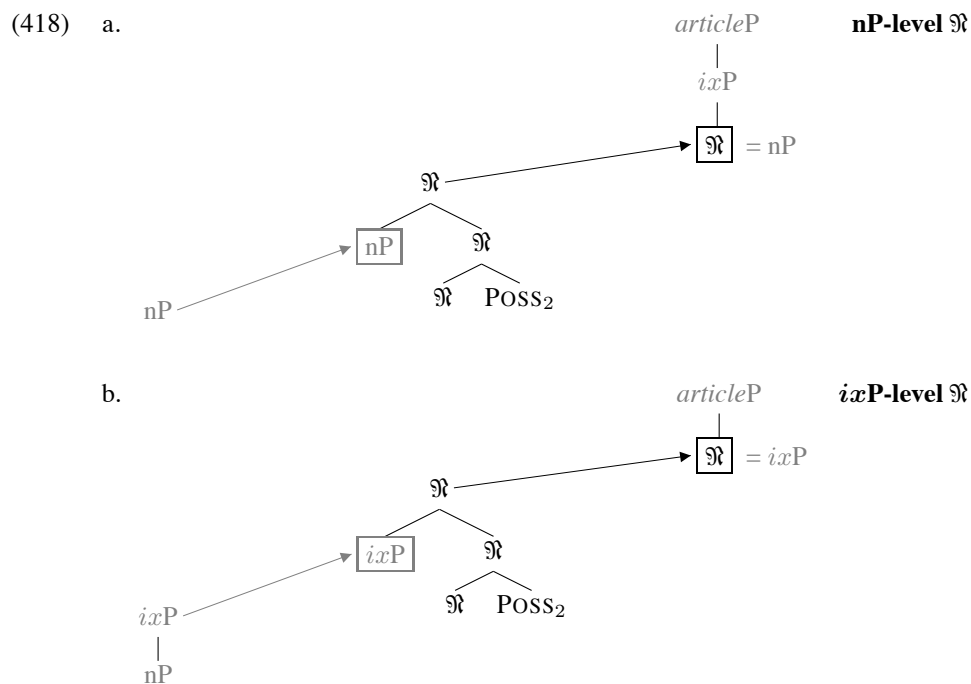

⁷We may consider it a “functional relational noun”.

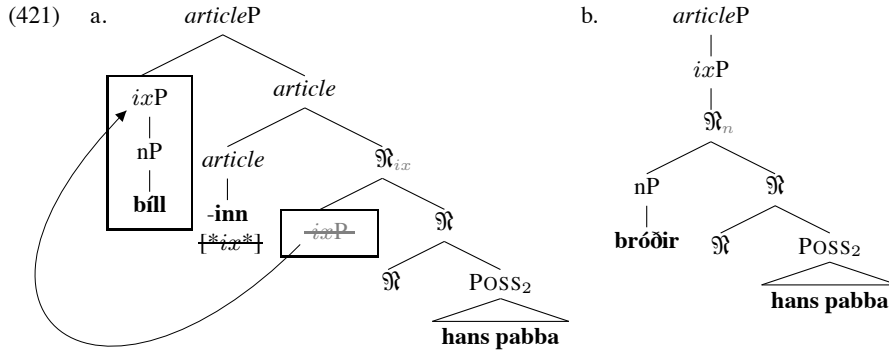

7.3.2 Inside and Outside the Index Phrase

By way of functional definition of *ix*, any nominal constituent of size *ixP* has its own referential index consisting of two integers, while a smaller constituent such as *nP* only has one integer (viz. the “standard of sameness”). In other words, the specifier of *ixP*-level \mathfrak{R} (being an *ixP* itself) has a full two-integer index before it combines with a GENITIVAL. *nP*-level \mathfrak{R} , on the other hand, lacks the second index, which is only introduced at *ixP*. But note that in that latter case, the standard of sameness, indicated by the first integer, can still be updated:

(422) a. *ixP*-level \mathfrak{R} :

b. *nP*-level \mathfrak{R} :

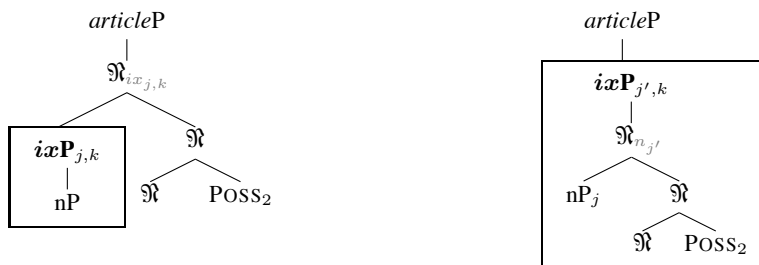

The boxed constituents in (422) represent the smallest nominal constituents that carry a full-fledged index, respectively. On Baker’s (2003) account, the standard of sameness is diagnosed as follows: *j* is the same *N* as *k*; on my implementation, *N* corresponds to *ixP* which carries the full index. The requirement of sameness is met by the specifier in (422a), that is, by the nominal alone, but a bigger structure necessarily comprising the GENITIVAL is required in (422b):

(423) a. *ixP*-level \mathfrak{R} :

cf. (420a)/(421a)/(422a)

X is the same car as Y

b. *nP*-level \mathfrak{R} :

cf. (420b)/(421b)/(422b)

X is the same brother of dad’s as Y

That nP-level \mathfrak{N} really requires the GENITIVAL can be illustrated by the badness of the following example:

(424) #X is the same brother as dad's brother

On the relevant reading,⁹ this example shows that “brother” and “dad’s brother” do not have the same standard of sameness. This is because the latter has an updated standard of sameness.

On a traditional construal of GENITIVALS as (internal) arguments selected by relational nouns on the one hand: λx . brother(dad)(x), and (external) modifiers when combined with common nouns on the other hand: λx . car(x) & R(dad)(x), it seems intuitively clear that noun and GENITIVAL form a closer unit in the former case. After all, the GENITIVAL fills an argument slot in the nominal structure, and thus the head noun is dependent on it: the noun phrase would not be complete without it. In the latter case, the head noun is largely independent of the GENITIVAL; it figures as a separate conjunct.

Pretty much the same effect is achieved with the two structures (422a) vs. (422b) without having to resort to notions like argument structure or some spurious argument vs. modifier distinction. In both cases, the GENITIVAL is a structural complement to \mathfrak{N} . The difference lies with the nominal projection occurring in the specifier.

In a structure of *ixP*-level \mathfrak{N} , the specifier is itself an *ixP*, i.e. a nominal projection with a full fledged two-integer index of its own. This property of having an index crucially accounts for the “head noun’s” greater syntactic and semantic independence of the GENITIVAL, cf. (422a). In (422b), on the other hand, noun and GENITIVAL in nP-level \mathfrak{N} form a close unit not because the GENITIVAL is an argument of the noun, but because the the minimal projection that is fully indexed comprises both. The nP specifier of \mathfrak{N} is not independent of the GENITIVAL insofar as the latter updates the standard of sameness set by the former.

In this sense, a structure like nP-level \mathfrak{N} can – in the spirit of SoS – easily dispense with notions like *relational nouns* and *argumental GENITIVALS*. Moreover, it can just as well account for other noun-GENITIVAL constituents that intuitively form a unit – structurally and conceptually – but where it is hard to construe the nominal as transitive and the GENITIVAL as argument of the noun:¹⁰

⁹This example may be felicitous on the irrelevant *freeR* reading.

¹⁰The relation that comes closest to capturing the following examples is presumably what Adger terms ‘representation’.

- (425) a. starfsmaður mánaðarins
 employee month.the.GEN
 ‘the employee of the month’
 b. bíll framtíðarinnar
 car future.the.GEN
 ‘the car of the future’
 c. fáni lýðveldis
 flag democracy.GEN
 ‘the flag of democracy’
 d. eldur ástarinnar
 fire love.the.GEN
 ‘the fire of love’

Incidentally, examples like these could pose another problem to Adger’s \mathfrak{P} -structure, which becomes apparent when we add a non-intersective adjective:

- (426) hinn meinti starfsmaður mánaðarins
 ART alleged employee month.the.GEN

Adger (2013) argues that intersective adjectives are subconstituents of \hat{N} . But since he moreover argues that \hat{N} also contains numerals, it is not immediately clear where else non-intersective adjectives should be merged (so as to comply with Greenberg’s U20: Num >> Adj >> N) if not also inside \hat{N} . The same is true for the ixP -level \mathfrak{N} structure: typical non-intersective adjectives such as *meintur* ‘alleged’ are merged ixP -internally, and as such must be assumed to be inside the specifier position of (ixP -level) \mathfrak{N} . On these two rather similar views, an example such as (426) is expected to have the structure(s) in (427a/b):

- (427) a. (~ Adger 2013)

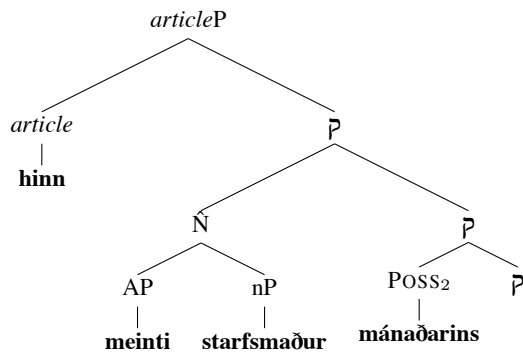

- b. ixP -level \mathfrak{N}

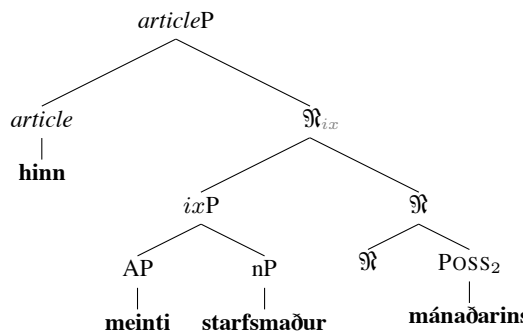

In both structures, the adjective is predicted to only scope over the noun, not the GENITIVAL (or the relation): ιx . alleged(\wedge employee(x)) & R(x , the month). In other words, (427) is about an alleged employee (who is somehow related to “the month”). Intuitively, this is not what (426) means because noun and GENITIVAL together form a conceptual unit, and the adjective must have scope over that entire unit: ιx . alleged(\wedge (employee(x) & R(x , the month))). This should be reflected structurally, but I cannot see how Adger’s \mathfrak{p} -structure can be made to accomplish this. \mathfrak{R} , on the other hand, comes in various sizes; above, I suggested that examples such as the one under consideration be analysed with an nP-level \mathfrak{R} . Inside this structure, in turn, the adjective can be merged ιx P-internally and still have scope over the N - GENITIVAL constituent:

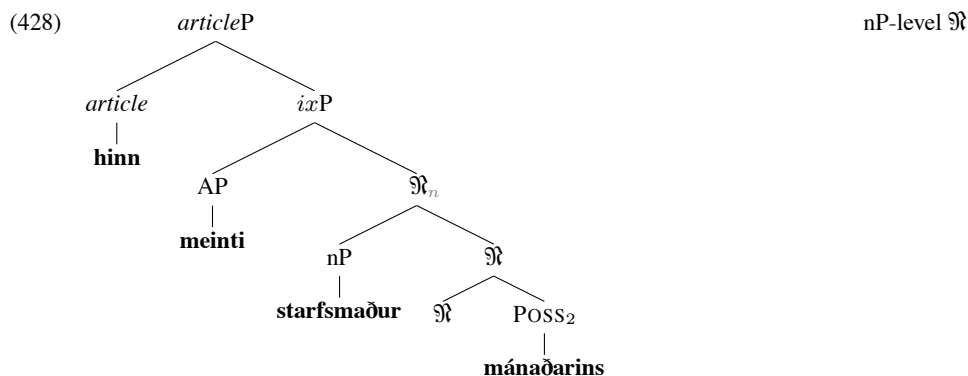

7.3.3 Sizes

Even though I am mostly concerned with nP and ιx P, the account developed here is fully compatible with a more fine-grained nominal structure, i.e. with there being more (functional) projections between NP and ιx P (and above ιx P). This has consequences for \mathfrak{R} . The discussion so far might give the misleading impression that I assume exactly two brands of \mathfrak{R} : ιx P-level and nP-level. In actual fact, I assume that \mathfrak{R} can be inserted at any height in the nominal fseq, either somewhere between NP and ιx P, or even above ιx P such that we might, in principle, even find an *articleP* in Spec- \mathfrak{R} :

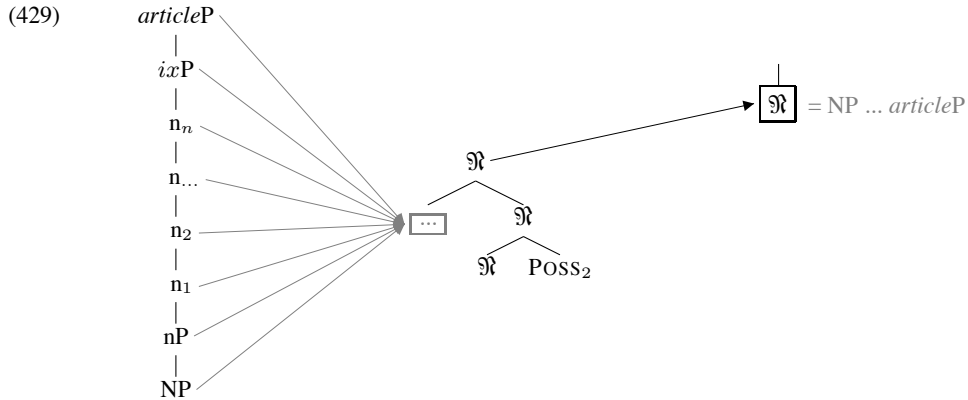

I will not explore the theoretical and empirical consequences. One conceivable area of investigation concerns structures where POSS_2 does not actually host GENITIVALS, but other peripheral noun modifiers such as PPs (which, as a matter of fact, is Adger's (2013) primary objective), or, possibly, even relative or argumental (*that*) clauses. I will leave that to future research.

7.3.4 Anchoring

Furthermore, since it is ixP that is attracted (by DEF), not nP , a distinction between ixP -level and nP -level can account for the fact that we find extraction in some cases (namely, when $\text{Spec-}\mathfrak{N}$ is an ixP), but not in others (namely, when $\text{Spec-}\mathfrak{N}$ is an nP). There are two concerns I will briefly address.

Firstly, since it is ixP that is attracted, the question arises why an ixP that embeds an (nP -level) \mathfrak{N} as in (422b) cannot also be attracted. Moreover, since I argue that \mathfrak{N} inherits its categorial specification from its specifier, and since ixP is categorially attracted, \mathfrak{N}_{ix} should just as well be attracted. In other words, it seems as though (part of) the original problem has not disappeared, but is still lurking around: how come ixP and \mathfrak{N}_{ix} are not attracted in (430a/b)?

(435) ⇒ *ixP*-level:

- a. hestar -nir þrír fræg.u (hans) pabba
 horses - DEF three famous.WK [he dad]-GEN
- b. hinir þrír fræg.u hestar (hans) pabba
 ART three famous.WK horses [he dad]-GEN
- c. þrír fræg.ir hestar (hans) pabba
 three famous.STR horses [he dad]-GEN

(435a) illustrates a paradigm case of genitive stranding with the postnominal modifiers highlighting the high position of *ixP* and the low position of the GENITIVE:

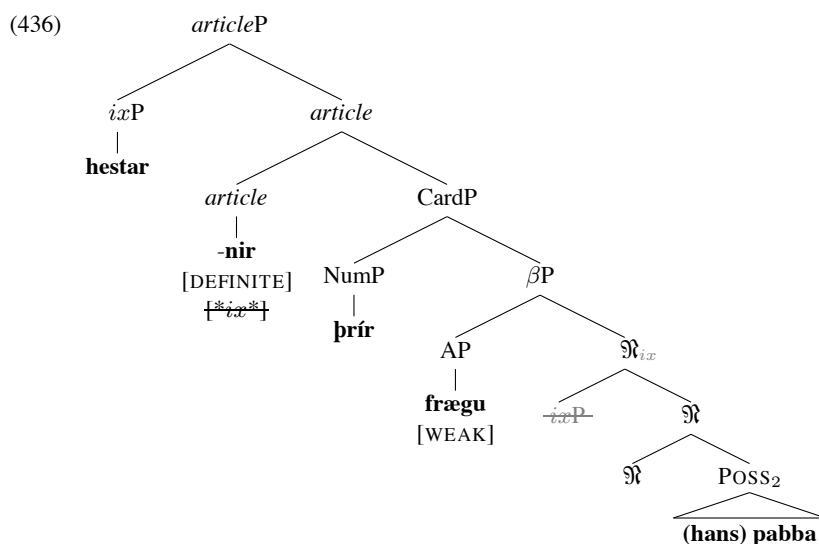

But if this example involves *ixP*-level \mathfrak{R} , (435b) and (435c) should likewise be considered to involve *ixP*-level \mathfrak{R} even though *ixP* does not move; after all, these examples obviously all involve the same (GPR) relation. In (435b), *ixP* is not attracted (and hence not extracted) because, as I argued in chapter 4, ART comprises DEF and a morpheme ‘h’ that satisfies the requirement posed by the feature $[\ast ix\ast]$ on DEF. In (435c), a case illustrating the ‘indeterminate’ reading, there is nothing that triggers *ixP* movement to begin with. Thus we can assume the following representations for (435b) and (435c):

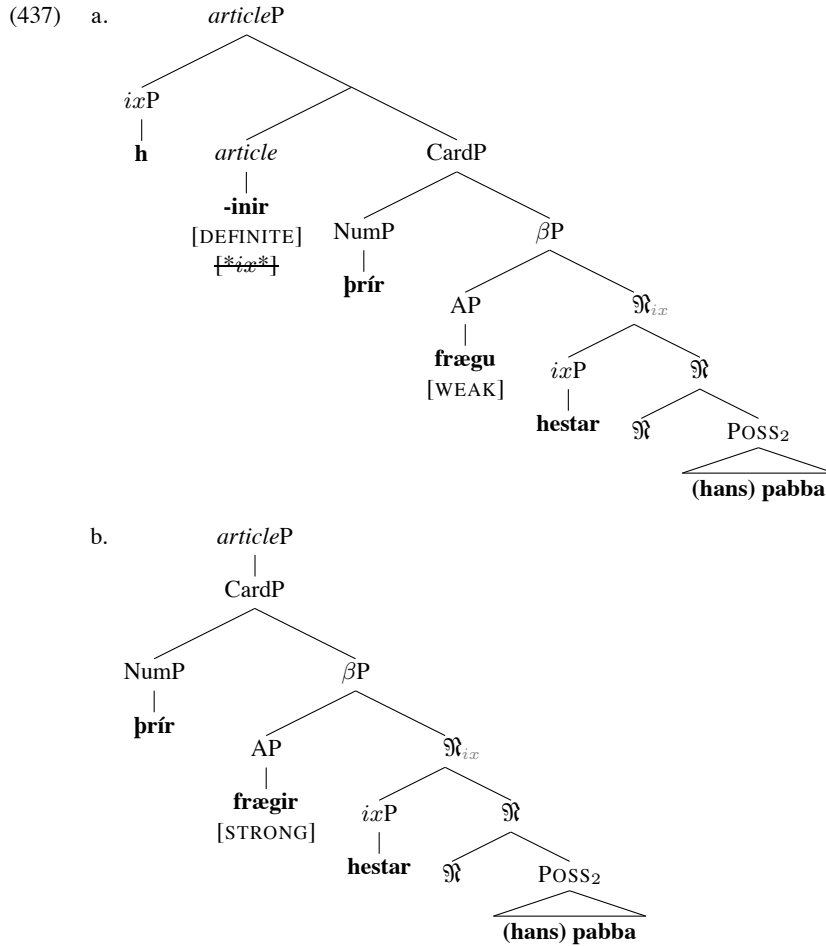

But this leaves us with a problem concerning the relationship between *pronominal possessives* in POSS₂ and *ixP*-level \mathfrak{R} . The problem arises when DEF (carrying [*ix*]) is merged: Extraction is possible and *ixP* does move to Spec-*articleP* thus stranding the GENITIVAL – provided it is a *DP-genitive*, cf. (437b); but *pronominal possessives* cannot be stranded in POSS₂:

- (438) *hestar - nir þrír fræg.u hans
 horses - DEF three famous.WK his

The assumed structure for (438) is given below:

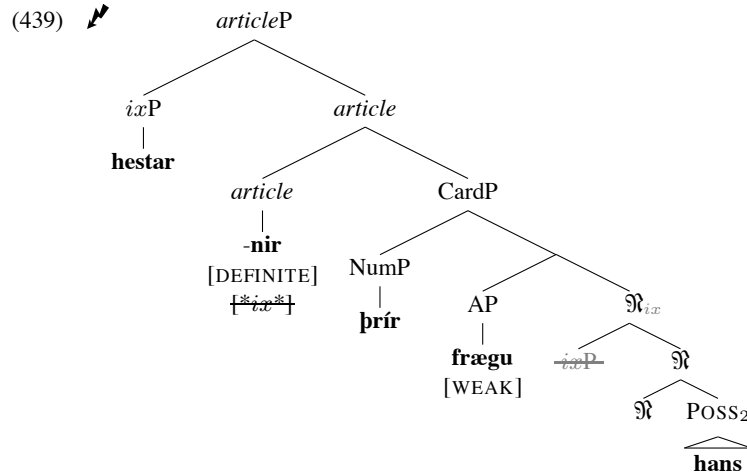

I do not know how to syntactically account for this problem. The only answer I can conceive of is that that structure is blocked by the existence of structures involving a *pronominal possessive* in POSS₁:

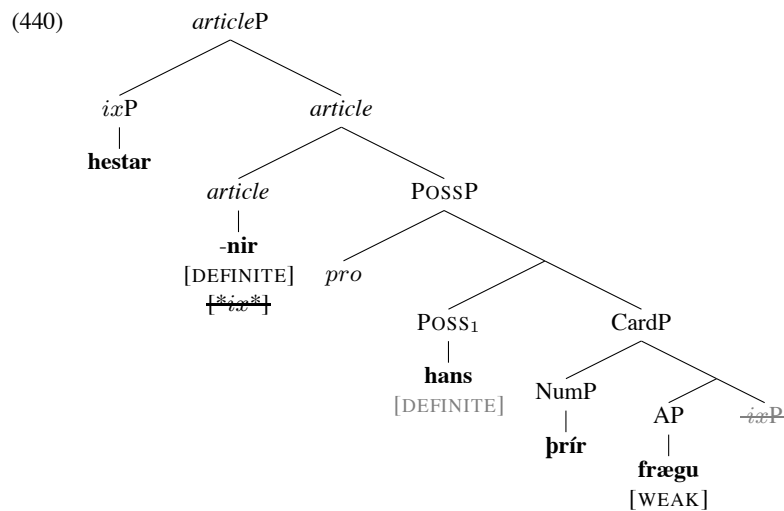

Now let us have a look at some more examples that I argue involve nP-level ḡ:

(441) ⇒ **nP-level:**

- a. hin algjör.a eyðilegging borgarinnar / hennar
ART total.WK destruction city.the.GEN / her (~ 'of it')
- b. algjör. eyðilegging borgarinnar / hennar
total.STR destruction city.the.GEN / her (~ 'of it')

- c. minn hluti arfsins / hans
 my part inheritance.the.GEN / his (~ 'of it')

(441) illustrates head nouns that, as we have seen, never occur in the high position while their (thematic/internal) arguments necessarily occur in POSS_2 . With a \mathfrak{N} structure, we have an explanation for ixP movement not taking place: Spec- \mathfrak{N} is a mere nP and thus cannot be attracted in the first place, and ixP is not anchored by the head noun. (441c) illustrates the curious case of two GENITIVALS occurring in POSS_1 and POSS_2 simultaneously. The structures are given below:

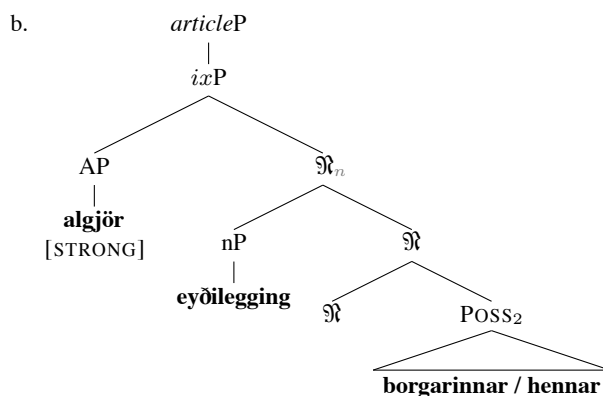
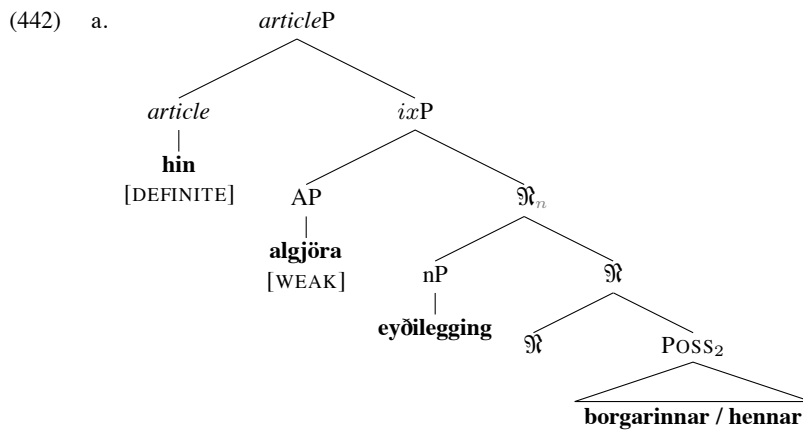

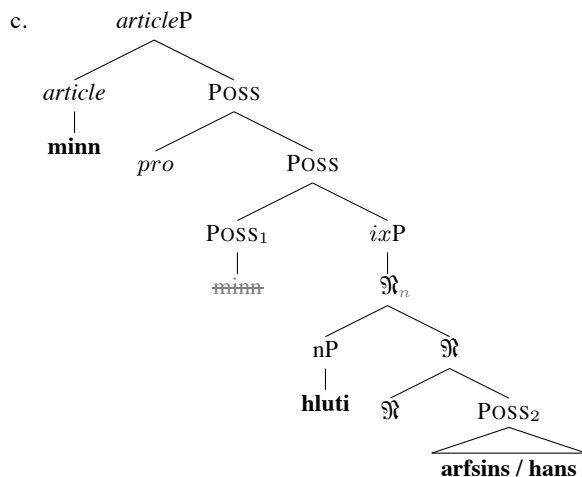

That curious case (441c)/(442c) raises a non-trivial question: what are the conditions/restrictions on $POSS_1$ and $POSS_2$ co-occurring in the same extended projection? It appears that $POSS_1$ can only be merged into a structure that already comprises a $POSS_2$ if the latter is a constituent of an nP-level \mathfrak{R} structure (and practically, only in a subset of those cases). To the extent that the observation is correct, and $POSS_1$ categorically cannot be merged above an ixP -level \mathfrak{R} structure, cf. (443a), we would have an account of why we never find two postnominal GENITIVALS occupying $POSS_1$ and $POSS_2$, respectively, even with head nouns that, in principle allow both positions to be filled, cf. (441c)/(442c): precisely those head nouns occur in an nP-level \mathfrak{R} structure that, by definition, does not allow extraction. Therefore we have the contrast (441c)/(442c) vs. (443b):

- (443) a. *minn bíll Jóns
 my car Jón.GEN
 b. *hluti (-nn) minn arfsins / hans
 part -DEF my inheritance.the.GEN / his

7.4 Summary

The low position $POSS_2$ has presented us with a poser: the phenomenon of genitive stranding is not straightforwardly analysable in terms of the structure and the set of assumptions developed in part I of this thesis. Inspired by Adger's (2013) \mathfrak{p} -structure, I proposed a modification of my system that involves a category-neutral functional relational noun \mathfrak{R} . \mathfrak{R} may be interspersed at different projection heights in the nominal extended projection and assumes the category of the constituent in its specifier position. I have especially focused on two settings of \mathfrak{R} , nP-level and ixP -level:

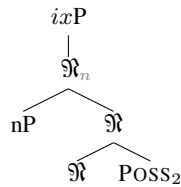
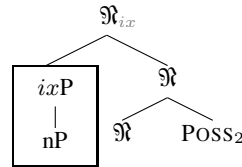
(444) a. nP-level \mathfrak{R} b. ixP -level \mathfrak{R} 

An ixP -level \mathfrak{R} structure allows us to construe both ixP and $POSS_2$ as phrasal units within one constituent that does not contain strandable (i.e. ixP -external) modifiers. This, in turn, allows us to provide a straightforward analysis of genitive stranding. Notably, we can derive the relevant cases with only one operation, viz. ixP -movement to Spec-*articleP*:

(445)

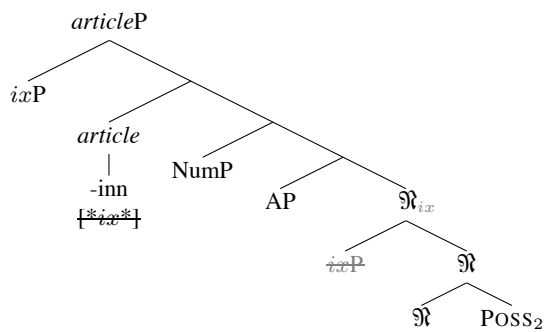

In addition, a differentiation of nP-level and ixP -level allows us to abandon the traditional distinction relational vs. common nouns (as the syntactic basis of the *possessum*), and concomitantly, the distinction arguments of nouns vs. POSSESSORS (regarding the status of the *possessor*) – while retaining the intuition underlying that distinction. On my account, the nature of the relation between *possessum* and *possessor* is determined by the height in the structure at which \mathfrak{R} is incorporated. For instance, in an nP-level \mathfrak{R} structure, which largely corresponds to a traditional “relational noun”-“argumental genitive” constellation, the GENITIVAL in $POSS_2$ updates the standard of sameness, which reflects the intuition that head noun and GENITIVAL form a close unit, both syntactically and conceptually. On the other hand, in an ixP -level \mathfrak{R} structure, the head noun constituent (i.e. ixP), carries a full index and is more independent of the GENITIVAL, syntactically and semantically. In Icelandic, this independence is manifested by the fact that the head noun constituent can be extracted from an ixP -level \mathfrak{R} (but not from nP-level \mathfrak{R}).

Summary Part II

The structure elaborated in Part I of this thesis, expanded simply and linearly, as it were. That is, from bottom to top ($nP > ixP > articleP > KP$), we have a delicate and multifaceted, but crucially *one* extended projection. A discussion for instance of higher determiners like demonstratives and quantifiers would surely be interesting and revealing in many ways, but those are unlikely to add crucially more complexity to the structure.

GENITIVALS, as we have seen in Part II of this thesis, do add a considerable amount of complexity (which goes especially for *DP-genitives*). We have seen that we have to assume two distinct positions $POSS_1$ and $POSS_2$ that are not derivationally related even though they often appear to make exactly the same semantic contribution:

- (446) a. bíll - inn hans POSS₁
car - DEF his
- b. i. bíll - inn hans Jóns POSS₂
car - DEF [he Jón]-GEN
- ii. bíll (%-inn) kennarans
car -DEF teacher.the.GEN

There are several reasons as to why the two positions cannot be related. The first one is internal and follows from my basic assumptions (DEF is merged in a high position, no remnant/roll-up movement). Secondly, I have provided evidence that $POSS_2$ is a phrasal constituent, whereas $POSS_1$ is a head position. Moreover, in certain cases, both positions can be simultaneously lexicalised, namely with part-whole nouns. We have also seen that there are substantial semantic differences between the two positions: a *possessor* in $POSS_1$ must be [+HUMAN], and cannot denote the “whole” argument of part-whole nouns nor a thematic argument of deverbal AS nouns. Finally, only a GENITIVAL in $POSS_1$ makes the noun phrase formally definite and systematically triggers weak inflection on (*articleP*-internal) adjectives. Noun phrases merely involving a GENITIVAL in $POSS_2$ (but no definite

determiner), on the other hand, are “indeterminate”; that is they allow both definite and indefinite readings. They cannot trigger weak inflection on adjectives by themselves, either.

The high position POSS₁ can easily be incorporated into the structure developed in Part I of the thesis. In a descriptive manner of speaking, high *pronominal possessives* along with numerals and pattern (III) adjectives fall into a group of (*articleP*-internal) elements merged between *ixP* and *article* that get stranded in postnominal position if *ixP* movement takes place. Differently from the latter, however, *pronominal possessives* can move from POSS₁ to *article*⁰ and thus shift from a modifier type to a determiner type.

The real complexity I alluded to above is contributed by the low position POSS₂. For theory-internal reasons I rejected the idea that it is a low specifier position (Spec-NP/Spec-nP) below adjectives right from the beginning for this would completely annihilate any simple and straightforward derivation of the weak patterns as argued for in part I of the thesis. Also the assumption that POSS₂ is the complement position of N proved futile because it would offer no viable approach to the phenomenon of genitive stranding. A question that both approaches leave untouched is on the status of the relation involved. I proposed that there is a category-neutral functional relational noun \mathfrak{N} that, on the one hand, hosts both POSS₂ and some extended projection of the head noun as phrasal constituents, and on the other hand, negotiates relationality between *possessor* and *possessum*. In conjunction with the idea of a referential index as introduced in chapter 5, this idea proves very powerful and allows us to approach both syntactic and semantic aspects from a new perspective. On the syntactic side, it offers an elegant way to analyse the phenomenon of genitive stranding in a manner which is consistent with the derivation of the adjectival patterns/*articleP* and requires no additional operations other than *ixP* movement to Spec-*articleP*. On the semantic side, it allows us to dispense with a categorical distinction between internal argumental and general possessive relations. The nature of the relation between *possessor* and *possessum* is determined by the height at which \mathfrak{N} is merged into the structure. In the discussion, I have simply made binary distinction between *ixP*-level and nP-level \mathfrak{N} structures, but I have likewise suggested that \mathfrak{N} is more flexible.

Chapter 8

General Overview and Outlook

The thesis has progressed from a detailed description of quite diverse and subtle data towards a rather simple analysis of that data. A large portion of the examples have not been previously discussed in the literature. In parallel, I have provided a number of novel empirical observations and generalizations, and put some old observations in a new perspective.

While I have not argued against remnant and roll-up movement per se, that is, on theoretical grounds, I have shown that, given certain assumptions about phrase structure, we can derive all patterns of adjectival and genitival modification in a straightforward fashion with only one criterial movement operation. At the same time, we capture a number of substantial semantic properties of modified structures and morpho-syntactic facts about (non-) strandability and adjectival inflection – without any additional assumptions. Thus, in terms of simplicity and efficiency, the analysis developed here is superior to analyses that need to resort to (often unmotivated) word order movements, different classes or kinds of adjectives, and/or distinctions between (lexical) relational and common nouns. Since the analysis presented here is largely data-driven and specially tailored for Icelandic data, for the moment, it does not make any claims about languages other than Icelandic. In the following, I will summarize the most important aspects of the analysis, and point out some consequences for the analysis of noun phrases at large.

8.1 Zones

I have argued that adjectival modification in Icelandic provides morpho-syntactic and semantic evidence for a segmentation into four distinct zones in the noun phrase. Rather straightforwardly, these zones are (sub-) constituents of the extended projection determined by the nominal fseq:

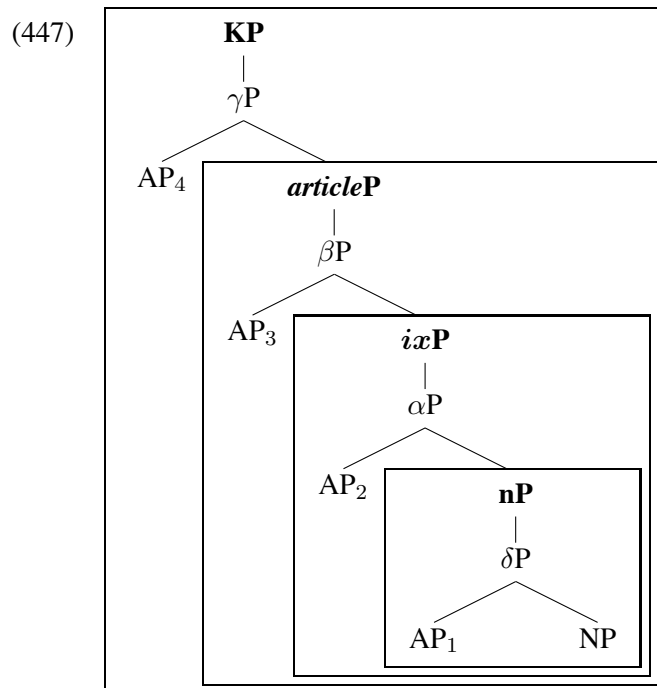

Each zone defines a semantic domain that can be considered an expansion of the denotation of the lower zone (or the nominal root in the case of nP). In other words, the object denoted by the nominal projection grows in a zone-wise fashion from concepts (nP) to kinds (*ixP*) to individuals (*articleP*) etc.. This characterization coincides with the suggestion made in the summary to part I of the thesis that these zones can be conceived of as sortal domains.

We have furthermore seen that *DP-genitives* add considerable complexity to the noun phrase structure. I have argued that a head noun – genitive constellation can be captured as a specifier – complement relationship in a \mathfrak{R} -structure. The conception of \mathfrak{R} as categoryless, i.e. non-substantial, functional relational elements that have no a priori determined position in the nominal fseq allows us to straightforwardly integrate \mathfrak{R} -structures into a layered noun phrase structure as sketched in (447) above. So even though a \mathfrak{R} projection is more complex in terms of the structure it hosts, it nonetheless delimits the same zone as determined by the constituent in its specifier position. Below I give the representations of the two relevant structures that I have used in the discussion:

(448) a. \Rightarrow *nP-level* \mathfrak{R} :

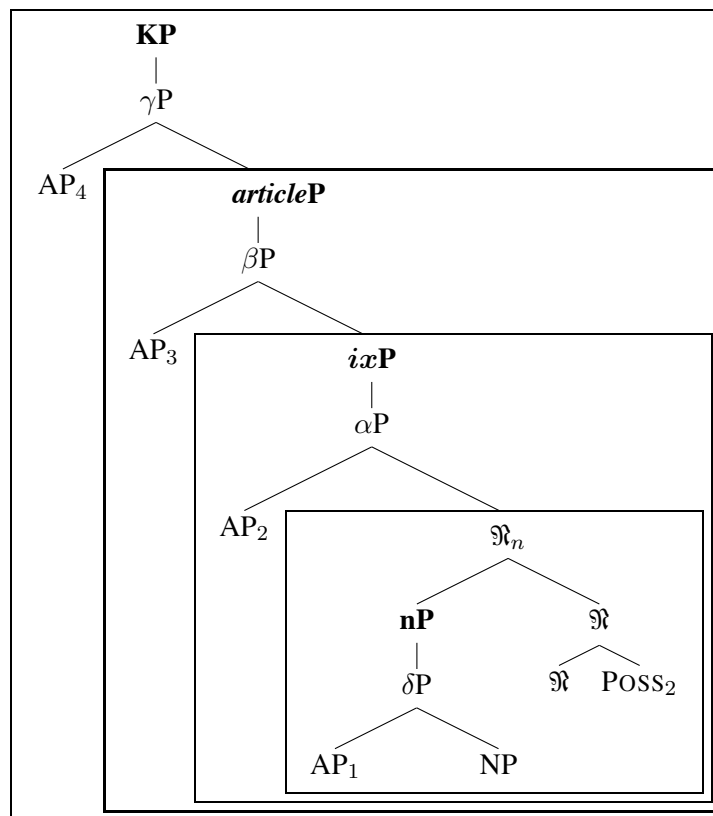

b. \Rightarrow *ixP*-level \mathfrak{R} :

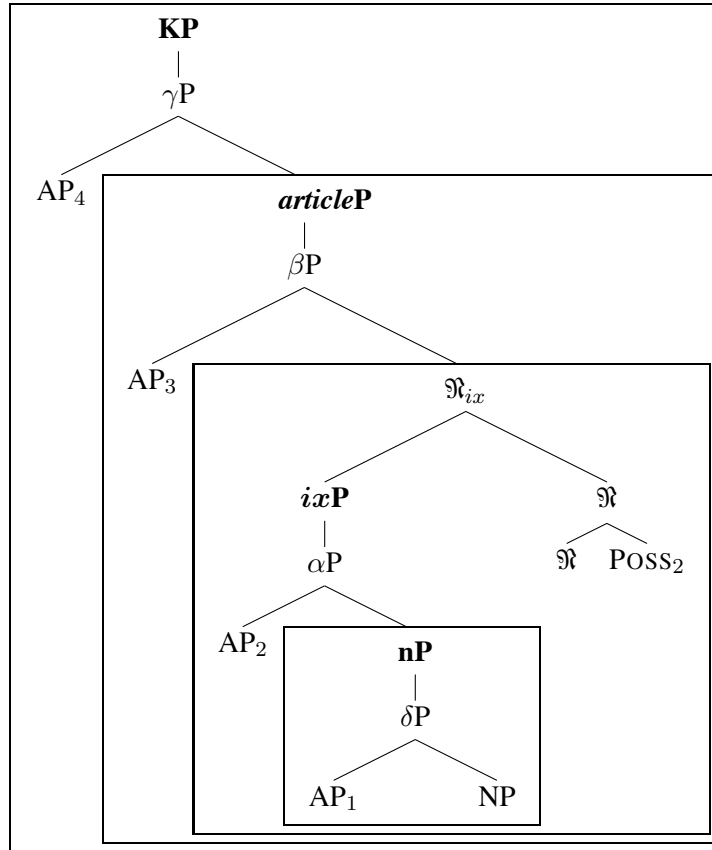

In all cases, the nP-zone is properly contained in the *ixP*-zone, which, in turn, is properly contained in the *articleP*-zone etc.. To the extent that the zone inside which a modifier is merged determines the properties of the modified object, adjectival and genitival modification can largely be treated uniformly. In both cases, we can, for instance, talk about nP-internal and *ixP*-internal modifiers.

8.2 Adjectival Semantics

I have not addressed the internal structure of APs, nor the semantic specifics of adjectival modification as such in any detail. In my system, the entity the adjective modifies is determined by the zone in which it is merged, and thus the semantics of adjectival modification follows entirely from the adjective's merge position (for instance: nP-internal adjectives can have idiomatic/thematic readings; *ix*P-internal/nP-external adjectives can modify kinds and update the standard of sameness, *ix*P-external adjectives are backgrounded, modify individuals and cannot update the standard of sameness, *article*P-external adjectives modify referential expressions etc.).

Abstracting away from the concrete cases I have discussed, the obvious advantage in the long run is that we seem to have a means to dispense with a number of classifications or dichotomies such as intersective vs. non-intersective adjectives, indirect vs. direct modifiers, adjectives vs. (reduced) relative clauses, heads vs. phrases, predicates vs. individuals etc., and maintain that there is essentially only one kind of adjective, which may be merged at different heights.

Steps in this direction have already been taken for instance by Larson (1998) who discusses the well-known ambiguity of examples such as the following:

- (449) Olga is a beautiful dancer
- | | |
|-----------------------------------|----------------------------|
| a. Olga is beautiful and a dancer | intersective |
| b. Olga dances beautifully | non-intersective/adverbial |

On Siegel' (1976) account, there are two lexical entries (doublettes) of the adjective, *beautiful*₁ and *beautiful*₂, one of which is (lexically) specified as intersective and the other one as non-intersective. On Cinque's (2010) account, *beautiful* on the non-intersective reading is construed as a direct modifier, whereas on the intersective reading, it is construed as a RRC. Thus one way or another, accounts like these suggest that there are two kinds of adjectives.¹

In contrast, Larson takes the blame away from the adjective, and directs it at the noun. In other words, the ambiguity is not the adjective's fault, but a consequence of the respective component of the nominal structure which the adjective is a predicate of. More specifically, he proposes that the nominal structure comprises both individual and event variables, and the adjective can be predicated of either. Predication over individuals results in the "intersective" reading, predication over events in the "non-intersective" reading:

¹Recall, however, that Cinque, in addition, assumes that RRCs are merged further away from the noun than direct modifiers, i.e. the difference of the adjective correlates with a difference in structural position.

- The intersective/nonintersective ambiguity arises from the semantic structure of N, not that of A.
- There are in fact no truly “non-intersective” readings. It [is] simply a matter of intersecting the A denotation with different sets (dancers versus dancers).²
- No semantic division of the category AP arises: they’re all predicates, but they are predicated of different things.

(Larson 1998:154)

In a similar manner, McNally and Boleda (2004) propose that relational adjectives are properties of Carlsonian kinds (see section 4.2.3), and argue that examples like ‘technical architect’ are amenable to an “intersective” analysis along the same lines as ‘beautiful dancer’ on the non-intersective/adverbial reading. The difference is that the adjective is construed as a predicate over events in the latter case, but as a predicate over kinds in the former.

Essentially, both proposals aim at rendering distinctions like intersective vs. non-intersective/subjective epiphenomenal. This means (for all relevant cases) that perceived semantic differences or ambiguities are not a consequence of a difference in adjectival semantics per se; the semantics of adjectival modification works the same way in all those cases. Rather the difference lies entirely with the entity that is modified, where the modified entity is a semantic constituent of the nominal structure.

There is a strong sense in which the zonal structure developed in this thesis, cf. (447), is a logical continuation of this line of reasoning. The semantic specifics of adjectival modification are indeed only a function of the entity that is modified. My account merely adds a structural component: an entity is defined by its respective zone, and can be said to grow incrementally, in a zone-wise fashion. In other words, extended nominal projections denote different entities depending on their structural size. Therefore, the height of the adjective’s merge position in the nominal fseq determines which entity the adjective combines with and modifies.

²Strictly speaking, “intersective” is a misnomer, even on Larson’s account, for “intersecting the A denotation with different sets” suggests that A itself denotes a set of individuals in the one case and a set of events in the other case, and in this sense, the adjective would be ambiguous after all.

8.3 Possession

Inspired by Adger's (2013) \wp structures, I have proposed that the relationship between head noun and GENITIVAL is mediated by a \mathfrak{N} structure. The original motivation for this move stems from an Icelandic-specific problem, viz. genitive stranding. The consequences are, however, more far-reaching. Since \mathfrak{N} is rather flexible and may be merged at various heights in the nominal structure, the position at which it is inserted directly correlates with the structural size of the head noun constituent. Simultaneously, the height of insertion of \mathfrak{N} into the nominal structure has an immediate impact on the semantic relation between *possessum* and *possessor*.

ixP-level \mathfrak{N} comprises an *ixP* specifier, *nP*-level \mathfrak{N} an *nP* specifier; only the former allows genitive stranding (which may be an Icelandic-specific fact). In an *ixP*-level \mathfrak{N} structure, the possessive relation is a GPR (*general possessive relation*), whereas in an *nP*-level \mathfrak{N} structure, it is an IPR (*inherent possessive relation*). I have argued that the distinction between *ixP*-level and *nP*-level \mathfrak{N} simulates the distinction between modifier genitives and argumental genitives, in that *possessum* and *possessor* form a closer conceptual unit in the latter case. This perspective basically allows us to dispense with the notion *relational noun*.

As in SoS, relationality is negotiated in the syntax. The difference is that Adger assumes that the nature of the respective relation is encoded in a small number of \wp roots. On my account, the nature of the relation is entirely determined by the height at which \mathfrak{N} is inserted, which amounts to stating that the perceived differences concerning the semantic nature of the respective possessive relation are a consequence of the GENITIVAL combining with *ixP* or *nP* (or NP ...). More broadly speaking, the semantics of genitival modification as such is the same in all cases. What is different is the entity that is modified, and the respective entity, as we have seen, is defined by zones.

This means that adjectival and genitival modification can be assimilated to a great extent in that both adjectival and genitival modifiers are, respectively, uniform across the board. The semantics of modification is simply a function of the entity to be modified which is defined by the zone in which the modifier is merged.

So once more, the notion *zone* proves very powerful, and to the extent that \mathfrak{N} structures are viable, we have a prospect for simplifying and unifying adjectival and genitival modification considerably.

There are some issues that need to be examined more carefully, though. For instance, the way I have set up my system seems to leave some wiggle room for the notion *X-internal* modifier in a \mathfrak{N} structure. Consider the following example:

8.4 Beyond Icelandic?

As has already been pointed out, the analysis developed here is based on Icelandic data, and, strictly speaking, only covers a subset of phenomena. Hence, certain components of the analysis are likely to capture facts about Icelandic rather than facts about *language*.

Take for instance *the* central operation in my analysis: *ixP*-movement. At least two aspects must be assumed to be Icelandic-specific: movement itself – obviously, not every language has suffixed articles – and the feature [**ix**]. If there is indeed a criterial feature like [**ix**] that triggers *ixP*-movement in Icelandic and is also found in languages without suffixed articles, one could imagine that languages differ as to whether that feature can be satisfied via Spec-Head (\rightarrow movement) or via downward probing/AGREE (\rightarrow no movement). In this context, it might be revealing to have a closer look at languages with arguably morphologically complex free articles in order to examine whether those comprise a morpheme that can satisfy that feature the way I argue ‘h’ does in Icelandic. An obvious candidate for comparison is the ‘d’-element of Germanic d-determiners (see Leu 2008).

These considerations are speculative; without a careful examination of other languages, it is not immediately clear to what extent a feature like [**ix**] exists or has effects in other languages. But the brief comments just given suggest that some aspects of that feature might be a matter of parametrization regarding the constituent that satisfies the requirement imposed by that feature (lexical *ixP* vs. a morpheme like ‘h’), or the mode of satisfying that feature (Spec-Head/movement vs. downward probing/AGREE).

Furthermore, languages might differ with respect to the size of the moveable nominal constituent. Based on the criterion of strandability, I argued for Icelandic that it is *ixP* that moves and that only *ixP*-external modifiers can be stranded. We do, however, find languages such as Spanish that can strand very low adjectives: *presidente francés* ‘president French_{thematic}’. Since thematic adjectives are merged nP-internally on my account, such examples might be taken to suggest that nP-internal adjectives can be stranded in such languages.

On the other hand, I submit that it is not merely a fact about Icelandic that there is a projection like *ixP*. Although motivated from different angles, the projection I labeled *ixP* and Zamparelli’s KIP essentially define the same (kind-denoting) zone (see section 4.2.3; (454a) below). A close similarity between the two is also suggested by (Truswell 2004:25) who argues that his Ref^0 “is close [...] to the KI^0 of Zamparelli (2000)” (see section 4.3.1, especially fn. 19). Recall that the function of Ref^0 on Truswell’s account is to introduce the second index which in turn prevents any further updating of the standard of sameness. This is one central aspect I

to have any correspondence in my system. Plausibly, it would be a projection somewhere between *ixP* and nP (Svenonius 2008 locates CL between nP and KiP) that defines a zone below *ixP*.

The closest cognate to Borer's # is presumably the projection I label CardP, but since I have treated numerals and quantifiers only peripherally, it is not entirely clear to what extent the two can be assimilated. In my system, numerals are basically treated on a par with *ixP*-external adjectives (they are potentially strandable). Granting that CardP has a designated status as Borer's #, then, following the logic of my system, CardP would have to be assumed to define another zone between *ixP* and *articleP*.

Beyond that, it is less obvious where the structural correspondences are and to what extent the technicalities are mutually convertible. The SDP layer/D could possibly be seen as corresponding to my KP zone, or alternatively, as collapsing my *articleP* and KP into one layer. On the other hand, my system does not have a component that resembles Zamparelli's PDP. A closer comparison I leave to further research.

Leaving aside potential extensions of my system, I would like to reiterate my commitment to the claim that an analysis that divides the noun phrase structure into zones captures a fact about language, not merely a fact about Icelandic. But once more, I will leave open the possibility that we find parametric variation, not regarding the number of zones, but the structural size of zones and the expectation that we may find language-specific diagnostics for each zone. Alternatively, it may be difficult to find clear diagnostics for a specific zone in a given language. Take as an example my KP zone (i.e. the zone between KP and *articleP*). Even though the idea that DP may not be a single projection but a fine structure in the sense of Rizzi (1997) is well established (see section 1.1.1), analyses along those lines tend to be quite different from my conception of the KP zone. Usually, such analyses focus on referential properties that are encoded in the D-layer, rather than on the aspect that *articleP* (\sim DP) denotes an entity that can be modified. I assume that this is a consequence of the fact that many languages – as far as I can tell – do not have anything comparable to pattern (IV) modifiers that I have used to diagnose the *articleP*-external KP zone. The reason for the absence of such modifiers might, at least to a certain extent, be a consequence of the D-layer being lexicalized differently (by articles, demonstratives ...) in different languages. That is, languages might resort to language-specific instantiations of D.

Considerations of this kind are at the core of the proposal developed by Wiltschko (2014). Her account of layered structures shares the number of layers/zones with my account, but goes otherwise well beyond my conception. Below, I repeat the general architecture proposed:

(455) **linking** >> **anchoring** >> **point-of-view** >> **classification**
 [KP [DP [PhiP [nP

(Wiltschko 2014)

Wiltschko explores the idea is that there is a small set of universal categories that are hierarchically organized (the *Universal Spine Hypothesis*). The core tenets of that idea are summarized as follows (op.cit.:24):

- i) Language-specific categories (c) are constructed from a small set of universal categories κ and language-specific UoLs [units of language]
- ii) The set of universal categories κ is hierarchically organized where each layer of κ is defined by a unique function.

In short, the layers (zones) as such are universal since they are determined by the hierarchy of universal categories. On the other hand, individual languages do not directly draw on that set of universal categories, but construct language-specific categories. As a consequence, (i) some categories may be missing in language L, (ii) some categories have different distributional properties in different languages, and (iii) some categories of L have no correlate in C_{UG} (cf. Wiltschko 2014:24). As a consequence, zones may have different properties in different languages.

I will thus conclude with the prospect that my zonal account of Icelandic can be expanded in a way that faces the challenges potentially posed by non-Icelandic languages and language variation.

This thesis has looked at the Icelandic noun phrase in a new way, and presented novel data and generalizations. Even though only a rather narrowly restricted set of phenomena has been investigated, the account given here is not exhaustive. There is still a lot of empirical work to be done and several aspects will have to be looked at more carefully. One secondary purpose of this thesis has been to inspire a number of new research questions for further investigation.

Apart from the purely empirical side, I have developed a novel analysis of the Icelandic noun phrase that integrates longstanding insights, aspects that have – in my opinion – been misconstrued in previous accounts and novel observations. Even though primarily tailored for specific Icelandic needs, the analysis proposed here has more far-reaching consequences for our assumptions about the noun phrase architecture and adjectival and genitival modification of noun phrases. To what extent (centrals aspects of) the analysis can be adopted for other languages is an open question for the time being.

Bibliography

- Abney, S. (1986). *Functional elements and licensing*. Paper presented at GLOW 1986. Gerona, Spain.
- Abney, S. (1987). *The Noun Phrase in its Sentential Aspect*. PhD thesis, MIT, Cambridge, MA.
- Adger, D. (2004). *Core Syntax. A Minimalist Approach*. Oxford University Press, Oxford.
- Adger, D. (2013). *A Syntax of Substance*. MIT Press, Cambridge, MA.
- Alexiadou, A. (2001). Adjective syntax and noun raising: Word order asymmetries in the DP as the result of adjective distribution. *Studia Linguistica*, 55(3):217–248.
- Alexiadou, A. (2012). *On the syntactic reality of restrictive adjectival modification*. Paper presented at the Workshop on Semantic and Pragmatic Properties of (Non) Restrictivity. University of Stuttgart, 19-20 March 2012.
- Alexiadou, A., Haegeman, L., and Stavrou, M. (2007). *Noun Phrase in the Generative Perspective*. Mouton de Gruyter, Berlin.
- Alexiadou, A. and Stavrou, M. (2005). *Ethnic adjectives as pseudo-adjectives: A case study on syntax-morphology interaction and the structure of DP*. Paper presented at the LAGB Annual Meeting, University of Cambridge, 03.09.2005.
- Alexiadou, A. and Stavrou, M. (2011). Ethnic adjectives as pseudo-adjectives: A case study on syntax-morphology interaction and the structure of DP. *Studia Linguistica*, 65(2):117–146.
- Alexiadou, A. and Wilder, C. (1998). Adjectival modification and multiple determiners. In Alexiadou, A. and Wilder, C., editors, *Possessors, Predicates and Movement in the DP*, pages 303–332. John Benjamins, Amsterdam.

- Árnason, K. (1980). *Íslensk málfræði. Kennslubók handa framhaldsskólum. Fyrri hluti*. Iðunn, Reykjavík.
- Árnason, K. (1983). *Íslensk málfræði. Kennslubók handa framhaldsskólum. Seinni hluti*. Iðunn, Reykjavík, 2. edition.
- Árnason, K. (2005). *Hljóð. Handbók um hljóðfræði og hljóðkerfisfræði*. Íslensk tunga I. Almenna bókfélagið, Reykjavík.
- Baker, M. (2003). *Lexical Categories: Verbs, Nouns and Adjectives*. Cambridge University Press, Cambridge.
- Barker, C. (2011). Possessives and relational nouns. In Maienborn, C., von Stechow, P., and Portner, P., editors, *Semantics: An international handbook of natural language meaning*, volume 2, pages 1109–1130. Mouton de Gruyter, Berlin.
- Bolinger, D. (1967). Adjectives in English: Attribution and predication. *Lingua*, 18:1–34.
- Borer, H. (2005). *In Name only (Structuring Sense, vol. I)*. Oxford University Press, Oxford.
- Börjars, K. and Harries, P. (2008). The clitic-affix distinction, historical change, and Scandinavian bound definiteness marking. *Journal of Germanic Linguistics*, 20(4):289–350.
- Bosque, I. and Picollo, C. (1996). Postnominal adjectives in Spanish DPs. *Journal of Linguistics*, 32(2):349–385.
- Brame, M. (1982). The head-selector theory of lexical specifications and the nonexistence of coarse categories. *Linguistic Analysis*, 10(4):321–325.
- Brody, M. (2000). Mirror theory: Syntactic representation in perfect syntax. *Linguistic Inquiry*, 31(1):29–56.
- Brugé, L. (1996). Demonstrative movement in Spanish: A comparative approach. In *University of Venice Working Papers in Linguistics 6.1*, pages 1–53. University of Venice.
- Cardinaletti, A. (1998). On the deficient/strong opposition in possessive systems. In Alexiadou, A. and Wilder, C., editors, *Possessors, Predicates and Movement in the Determiner Phrase*, pages 17–53. John Benjamins, Amsterdam.

- Cardinaletti, A. and Starke, M. (1994). The typology of structural deficiency: On the three grammatical classes. In *FAS Papers in Linguistics 1*, pages 1–55.
- Cardinaletti, A. and Starke, M. (1999). The typology of structural deficiency. In van Riemsdijk, H., editor, *Clitics and other functional categories in the languages of Europe*, pages 145–233. Mouton de Gruyter.
- Carlson, G. N. (1977). A unified analysis of the English bare plural. *Linguistics and Philosophy*, 1:413–457.
- Carstens, V. (2000). Concord in minimalist theory. *Linguistic Inquiry*, 31(2):319–355.
- Carstens, V. (2001). Multiple agreement and case deletion: Against (ϕ -) incompleteness. *Syntax*, 4:147–163.
- Chomsky, N. (1995). *The Minimalist Program*. MIT Press, Cambridge, MA.
- Cinque, G. (1994). On the evidence for partial N-movement in the Romance DP. In Cinque, G., Koster, J., Pollock, J.-Y., Rizzi, L., and Zanuttini, R., editors, *Paths towards Universal Grammar: Studies in Honor of Richard S. Kayne*, pages 85–110. Georgetown University Press, Washington D.C.
- Cinque, G. (1999). *Adverbs and Functional Heads: A cross-linguistic perspective*. Oxford University Press, Oxford.
- Cinque, G. (2005). Deriving Greenberg's Universal 20 and its exceptions. *Linguistic Inquiry*, 36(3):315–332.
- Cinque, G. (2010). *The Syntax of Adjectives: A Comparative Study*. MIT Press, Cambridge.
- Delsing, L.-O. (1991). Om genitivens utveckling i fornsvenskan. In Malmgren, S.-G. and Ralph, B., editors, *Studier i svensk språkhistoria 2*, pages 12–30. Institutionen för Nordiska Språk, Göteborg.
- Delsing, L.-O. (1993). *The Internal Structure of Noun Phrases in the Scandinavian Languages*. PhD thesis, University of Lund.
- Delsing, L.-O. (1998). Possession in Germanic. In Alexiadou, A. and Wilder, C., editors, *Possessors, Predicates and Movement in the Determiner Phrase*, pages 87–108. John Benjamins, Amsterdam.

- Demonte, V. (2008). Meaning-form correlations and adjective position in Spanish. In McNally, L. and Kennedy, C., editors, *Adjectives and Adverbs: Syntax, Semantics, and Discourse*, pages 71–100. Oxford University Press, Oxford.
- Einarsson, S. (1945). *Icelandic: Grammar, Texts, Glossary*. John Hopkins Press, Baltimore.
- Enç, M. (1981). *Tense without Scope: An Analysis of Nouns as Indexicals*. PhD thesis, University of Wisconsin, Madison.
- Enç, M. (1986). Towards a referential analysis of temporal expressions. *Linguistics and Philosophy*, 9(4):405–426.
- Enç, M. (1991). The semantics of specificity. *Linguistic Inquiry*, 22(1):1–25.
- Faarlund, J. T. (2004). *The Syntax of Old Norse*. Oxford University Press, Oxford.
- Faarlund, J. T. (2009). On the history of definiteness marking in Scandinavian. *Journal of Linguistics*, 45(3):617–639.
- Fabregas, A. (2007). The internal structure of relational adjectives. *Probus*, 19(1):135–170.
- Fabricius-Hansen, C. (2009). Überlegungen zur pränominalen Nicht-Restriktivität. *Linguistische Berichte*, 16:89–112.
- Friðjónsson, J. (1978). *A Course in Modern Icelandic I*. Skákprent, Reykjavík.
- Fukui, N. (1986). *A Theory of Category Projection and Its Applications*. PhD thesis, MIT, Cambridge, MA.
- Giusti, G. (1996). Is there a FocusP and a TopicP in the noun phrase structure? *Working Papers in Linguistics*, 6(2):105–128.
- Giusti, G. (2005). At the left periphery of the Romanian noun phrase. *On Space and Time in Language*, pages 23–49.
- Giusti, G. and Leko, N. (2005). The categorial status of quantity expressions. In Bosne, F., editor, *Linguistički Vidici*, pages 121–184, Sarajevo.
- Greenberg, J. (1963). Some universals of grammar with particular reference to the order of meaningful elements. In Greenberg, J., editor, *Universals of Language*, pages 73–113. MIT Press, Cambridge, MA.

- Grice, H. P. (1975). Logic and conversation. In Cole, P. and Morgan, J., editors, *Syntax and Semantics*, Speech Acts, Volume 3, pages 43–58. Academic Press, New York.
- Grimshaw, J. (1990). *Argument Structure*. MIT Press, Cambridge.
- Grimshaw, J. (1991). *Extended Projection*. Ms., Brandeis University.
- Guðfinnsson, B. (1943). *Íslensk setningafræði handa skólum og útvarpi*. Ísafoldarprentsmiðja, Reykjavík, 2. edition.
- Guðmundsson, V. (1922). *Íslensk grammatik: Íslensk nútíðsprog*. Málvísindastofnun Háskóla Íslands, Reykjavík. [Reprinted 1983].
- Harðarson, G. R. (2014a). *The structure of noun phrases and synthetic compounds*. Abstract submitted to the workshop “The North Germanic Noun Phrase” (held in Tromsø, May 22/23, 2014).
- Harðarson, G. R. (2014b). *Tumbling down the Icelandic Noun Phrase*. Ms., University of Connecticut.
- Heim, I. and Kratzer, A. (1998). *Semantics in Generative Grammar*. Blackwell, Oxford.
- Hellan, L. (1986). The headedness of NPs in Norwegian. In Muysken, P. and van Riemsdijk, H., editors, *Features and Projections*, pages 89–122. Foris, Dordrecht.
- Higginbotham, J. (1985). On semantics. *Linguistic Inquiry*, 16(4):547–593.
- Horrocks, G. and Stavrou, M. (1987). Bounding theory and Greek syntax: Evidence for wh-movement in NP. *Journal of Linguistics*, 23(1):79–108.
- Ihsane, T. (2000). Three types of possessive modifiers. *Generative Grammar in Geneva*, 1.
- Ihsane, T. (2003). A typology of possessive modifiers. In Coene, M. and D’huylst, Y., editors, *From NP to DP*, volume 2, pages 23–42. John Benjamins, Amsterdam.
- Ihsane, T. and Puskás, G. (2001). Specific is not definite. *Generative Grammar in Geneva*, 2:39–54.
- Indriðason, T. (1986). *Staða greinis í íslensku málkerfi*. BA thesis, University of Iceland.

- Indriðason, T. (1994). *Regluvirkni í orðasafni og utan þess. Um lexíkalska hljóðkerfisfræði í íslensku*. Master's thesis, University of Iceland.
- Jackendoff, R. (1977). *X-bar Syntax: A Study of Phrase Structure*. Linguistic Inquiry Monograph No. 2. MIT Press, Cambridge, MA.
- Jensen, P. A. and Vikner, C. (1994). Lexical knowledge and the semantic analysis of Danish genitive constructions. In Hansen, S. L. and Wegener, H., editors, *Topics in Knowledge-based NLP Systems*, pages 37–55. Samfundslitteratur, Copenhagen.
- Jespersen, O. (1924). *The Philosophy of Grammar*. Allen and Unwin, London.
- Jóhannsdóttir, K. M. (1995). The argument structure of deverbal nominals in Icelandic. In *Working Papers in Linguistics*, volume 25, pages 61–88. University of Trondheim.
- Jónsson, S. (1927). *A Primer of Modern Icelandic*. University Press, Oxford. [Reprinted 1941].
- Julien, M. (2002). Determiners and word order in Scandinavian DPs. *Studia Linguistica*, 56(3):265–315.
- Julien, M. (2003). Double definiteness in Scandinavian. *Nordlyd*, 31(1):230–244.
- Julien, M. (2005a). *Nominal Phrases from a Scandinavian Perspective*. John Benjamins, Amsterdam.
- Julien, M. (2005b). Possessor licensing, definiteness and case in Scandinavian. In den Dikken, M. and Tortora, C. M., editors, *The Function of Function Words and Functional Categories*, pages 217–249. John Benjamins, Amsterdam.
- Katzir, R. (2011). Morphosemantic mismatches, structural economy, and licensing. *Linguistic Inquiry*, 42:45–82.
- Kayne, R. (1994). *The Antisymmetry of Syntax*. MIT Press, Cambridge, MA.
- Kiparsky, P. (1982). From cyclic phonology to lexical phonology. In Goldsmith, J. A., editor, *Phonological Theory. The Essential Readings*, pages 34–62. Blackwell Publishers Ltd., Oxford.
- Kiparsky, P. (1984). On the lexical phonology of Icelandic. In Elert, C.-C., Johansson, I., and Strangert, E., editors, *Nordic Prosody 3. Papers from a Symposium*, pages 135–64, University of Umeå, Umeå.

- Kress, B. (1982). *Isländische Grammatik*. VEB Verlag Enzyklopädie, Leipzig.
- Kusumoto, K. (2000). Temporal interpretation of participles. In *Proceedings of the 19th West of Coast Conference on Formal Linguistics*, pages 260–273.
- Laenzlinger, C. (2005). French adjective ordering: Perspectives on DP-internal movement types. *Lingua*, 115(5):645–689.
- Larson, R. and Marušič, F. (2004). On indefinite pronoun structures with APs: Reply to Kishimoto. *Linguistic Inquiry*, 35(2):268–287.
- Larson, R. K. (1998). Events and modification in nominals. In *Proceedings of SALT*, volume 8, pages 145–168.
- Leffel, T. J. (2012). *Nonrestrictive adjectives and the theory of scalar implicature*. Paper presented at GLOW 2012. Potsdam, Germany.
- Leffel, T. J. (2014). *The Semantics of Modification: Adjectives, Nouns, and Order*. PhD thesis, New York University.
- Leu, T. (2008). *The Internal Syntax of Determiners*. PhD thesis, New York University.
- Lohrmann, S. (2008). The role of adjectival inflection in Scandinavian. *Proceedings of the LingO Conference*.
- Lohrmann, S. (2010). *The Structure of the DP and its Reflex in Scandinavian*. PhD thesis, University of Stuttgart.
- Lucas, M. A. (1975). The syntactic classes of antenominal adjectives in English. *Lingua*, 35(2):155–171.
- Magnússon, F. (1984). Um innri gerð nafnliða í íslensku. *Íslenskt mál*, 6:81–111.
- Marantz, A. (1997). No escape from syntax: Don't try morphological analysis in the privacy of your own lexicon. In Dimitrades, A. and Siegel, L., editors, *Proceedings of the 21st Annual Penn Linguistics Colloquium*, UPenn Working Papers in Linguistics, pages 201–225. University of Pennsylvania, Philadelphia.
- Martin, F. (2014). Restrictive vs. nonrestrictive modification and evaluative predicates. *Lingua*, 149(1):34–54.
- McKinney-Bock, K. (2010). Adjective ordering restrictions: exploring relevant semantic notions for syntactic ordering. In *Proceedings of the Arizona Linguistics Circle 3*.

- McNally, L. and Boleda, G. (2004). Relational adjectives as properties of kinds. *Empirical Issues in Formal Syntax and Semantics*, 5:179–196.
- Milsark, G. (1974). *Existential Sentences in English*. PhD thesis, MIT, Cambridge, MA.
- Morzycki, M. (2008). Nonrestrictive modifiers in nonparenthetical positions. In McNally, L. and Kennedy, C., editors, *Adjectives and Adverbs: Syntax, Semantics, and Discourse*, pages 101–122. Oxford University Press, Oxford.
- Musan, R. (1995). *On the Temporal Interpretation of Noun Phrases*. PhD thesis, MIT, Cambridge.
- Musan, R. (1999). Temporal interpretation and information-status of noun phrases. *Linguistics and Philosophy*, 22(6):621–661.
- Norris, M. (2011). Extraposition and definiteness effects in Icelandic DPs. In LaCara, N., Thompson, A., and Tucker, M., editors, *Morphology at Santa Cruz*. CA: Linguistics Research Center, Santa Cruz.
- Norris, M., Mikkelsen, L., and Hankamer, J. (2013). Licensing trouble. *Linguistic Inquiry*, 45:617–653.
- Núria, M. G. (2003). Partitives: One or two nouns. *Rivista di Grammatica Generativa*, 27:45–58.
- Nygaard, M. (1905). *Norrøn Syntax*. H. Aschehoug & Company (W. Nygaard), Kristiania.
- Ólafsson, J. (1915). *Litla móðurmálsbókin handa börnum og byrjendum*. Bókaverzlun Sigfúsar Eymundssonar, Reykjavík.
- Ottósdóttir, G. (2006). *Ólafsfjarðareignarfallið: Eignarsambönd í íslensku með áherslu á eitt lítið mállýskuafrigið*. BA thesis, University of Iceland.
- Panagiotidis, P. (2002). *Pronouns, Clitics and Empty Nouns: ‘Pronominality’ and Licensing in Syntax*. John Benjamins, Amsterdam.
- Partee, B. H. (1983/1997). Uniformity vs. versatility: The genitive – a case study. In van Benthem, J. and ter Meulen, A., editors, *The Handbook of Logic and Language*, pages 464–470. Elsevier, Amsterdam. [Paper originally written 1983].
- Partee, B. H. (2003). *Are there privative adjectives?* Paper presented at the Conference on the Philosophy of Terry Parsons, University of Massachusetts, Amherst.

- Partee, B. H. (2010). Privative adjectives: subsective plus coercion. In Bäuerle, R., Reyle, U., and Zimmermann, T. E., editors, *Presuppositions and Discourse: Essays Offered to Hans Kamp*, pages 273–285. Emerald, Bingley.
- Partee, B. H. and Borschev, V. (2000). Genitives, relational nouns, and the argument-modifier distinction. In Fabricius-Hansen, C., Lang, E., and Maienborn, C., editors, *ZAS Papers in Linguistics 17*, pages 177–201. Zentrum für Allgemeine Sprachwissenschaft, Sprachtypologie und Universalienforschung, Berlin.
- Partee, B. H. and Borschev, V. (2003). Genitives, relational nouns, and argument-modifier ambiguity. In Lang, E., Maienborn, C., and Fabricius-Hansen, C., editors, *Modifying Adjuncts*, pages 67–112. Mouton de Gruyter, Berlin and New York.
- Pfaff, A. (2007). *Eitt eða tvennt? Ákveðinn greinir í íslensku*. BA thesis, University of Iceland.
- Pfaff, A. (2009). *Structural Relations between Free and Suffixed Articles in Icelandic*. Master's thesis, University of Tübingen.
- Pfaff, A. (2014). Inside and outside - before and after. Weak and strong adjectives in Icelandic. In Sleeman, P., de Velde, F. V., and Perridon, H., editors, *Adjectives in Germanic and Romance*, pages 217–244. John Benjamins, Amsterdam.
- Pfaff, A. (2015). On the temporal anchoring of participial events (in German). In Fortmann, C., Lübke, A., and Rapp, I., editors, *Situationsargumente im Nominalbereich*. de Gruyter, Berlin and New York.
- Piñón, C. (2005). *Comments on Morzycki & Katz*. Ms., available at <http://pinon.sdf-eu.org/covers/cm.html>.
- Postal, P. (1966). On so-called pronouns in English. In Francis P. Dinneen, S. J., editor, *Report of the Seventeenth Annual Round Table Meeting on Linguistics and Language Studies*, volume 19 of *Georgetown University Monograph series on language and linguistics*. Georgetown University Press, Washington D.C.
- Postal, P. (1972). 'Pronominal epithets' and similar items. *Foundations of Language*, 9(2):246–248.
- Potts, C. (2003). *The Logic of Conventional Implicatures*. PhD thesis, University of California.

- Potts, C. (2005). *The Logic of Conventional Implicatures*. Oxford University Press, Oxford.
- Potts, C. (2007a). The centrality of expressive indices. *Theoretical Linguistics*, 33:255–268.
- Potts, C. (2007b). Conventional implicatures, a distinguished class of meanings. In Ramchand, G. and Reiss, C., editors, *The Oxford Handbook of Linguistic Interfaces*, pages 475–501. Oxford University Press, Oxford.
- Radford, A. (2004). *Minimalist Syntax. Exploring the Structure of English*. Cambridge University Press, Cambridge.
- Ramaglia, F. (2011). *Adjectives at the Syntax-Semantics Interface*. Lincom, München.
- Ramchand, G. and Svenonius, P. (2014). Deriving the functional hierarchy. *Language Sciences*, 46:152–174.
- Rapp, I. (2014). On the temporal interpretation of present participles in German. *Journal of Semantics*, doi:10.1093/jos/ffu005.
- Rizzi, L. (1997). The fine structure of the left periphery. In Haegeman, L., editor, *Elements of Grammar. Handbook of Generative Syntax*, pages 281–337. Kluwer, Dordrecht.
- Roehrs, D. (2006). *The Morpho-Syntax of the Germanic Noun Phrase: Determiners MOVE into the Determiner Phrase*. PhD thesis, Indiana University.
- Roehrs, D. (2009). *Demonstratives and Definite Articles as Nominal Auxiliaries*. John Benjamins, Amsterdam / Philadelphia.
- Rögnvaldsson, E. (1984). Af lýsingarorðsviðurlögum. *Íslenskt mál*, 6:57–80.
- Rögnvaldsson, E. (1990). *Íslensk orðhlutafræði. Kennslukver handa nemendum á háskólastigi*. Málvísindastofnun Háskóla Íslands, Reykjavík, 4th edition.
- Sadler, L. and Arnold, D. J. (1994). Prenominal adjectives and the phrasal/lexical distinction. *Journal of Linguistics*, 30(1):187–226.
- Schoorlemmer, M. (1998). Possessors, articles and definiteness. In Alexiadou, A. and Wilder, C., editors, *Possessors, Predicates and Movement in the Determiner Phrase*, pages 55–86. John Benjamins, Amsterdam.

- Scott, G.-J. (2002). Stacked adjectival modification and the structure of nominal phrases. In Cinque, G., editor, *Functional Structure in DP and IP: The Cartography of Syntactic Structures*, volume 1, pages 91–120. Oxford University Press, Oxford.
- Selkirk, E. O. (1977). Some remarks on noun phrase structure. In Culicover, P. W., Wasow, T., and Akmajian, A., editors, *Formal Syntax*, pages 285–316. Academic Press, New York.
- Siegel, M. (1976). *Capturing the Adjective*. PhD thesis, University of Massachusetts at Amherst.
- Sigurðsson, E. F. (2013). *Attributive resultative passives: The view from Icelandic*. Ms., University of Pennsylvania.
- Sigurðsson, H. Á. (1993). The structure of the Icelandic NP. *Studia Linguistica*, 47(2):177–197.
- Sigurðsson, H. Á. (2006). The Icelandic noun phrase. Central traits. *Arkiv för nordisk filologi*, 121:193–236.
- Skrzypek, D. (2009). The formation of the definite article in the Nordic languages. *Lingua Posnaniensis*, 51:65–76.
- Skúlason, S. (1944). *Kennslubók í íslensku*. Kvöldskóli K.F.U.M., Reykjavík.
- Smári, J. J. (1920). *Íslensk setningafræði*. Málvísindastofnun Háskóla Íslands, Reykjavík. [Reprinted 1987].
- Spencer, A. (1992). Nominal inflection and the nature of functional categories. *Journal of Linguistics*, 28:313–341.
- Sproat, R. and Shih, C. (1988). Prenominal adjectival ordering in English and Mandarin. In *Proceedings of NELS*, volume 18, pages 465–489.
- Sproat, R. and Shih, C. (1991). The cross-linguistic distribution of adjective ordering restrictions. In Georgopoulos, C. and Ishihara, R., editors, *Interdisciplinary Approaches to Language. Essays in Honor of S.-Y. Kuroda*, pages 565–593, Dordrecht. Kluwer Academic Publishers.
- Starke, M. (2004). On the inexistence of specifiers and the nature of heads. In Belletti, A., editor, *Structures and Beyond: The Cartography of Syntactic Structures*, volume 3, pages 252–268. Oxford University Press, Oxford.

- Sternefeld, W. (2006). *Syntax: eine morphologisch motivierte generative Beschreibung des Deutschen*, volume 1. Stauffenburg, Tübingen.
- Svenonius, P. (2006). The emergence of axial parts. In Svenonius, P. and Pantcheva, M., editors, *Nordlyd, Tromsø Working Papers in Language and Linguistics: 33.1, Special Issue on Adpositions*, pages 49–77. University of Tromsø, Tromsø.
- Svenonius, P. (2008). The position of adjectives and other phrasal modifiers in the decomposition of DP. In McNally, L. and Kennedy, C., editors, *Adjectives and Adverbs: Syntax, Semantics, and Discourse*. Oxford University Press, Oxford.
- Svenonius, P. (2010). Spatial P in English. In Cinque, G. and Rizzi, L., editors, *Mapping Spatial PPs: The Cartography of Syntactic Structures*, volume 6, pages 127–160. Oxford University Press, Oxford.
- Szabolcsi, A. (1987). Functional categories in the noun phrase. In Kenesei, I., editor, *Approaches to Hungarian*, volume 2, pages 167–189. JATE, Szeged.
- Szabolcsi, A. (1994). The noun phrase. In Kiefer, F. and Kiss, K. É., editors, *The Syntactic Structure of Hungarian*, volume 27 of *Syntax and Semantics*, pages 179–274. Academic Press, San Diego.
- Thráinsson, H. (1995). *Handbók um málfræði*. Námsgagnastofnun, Reykjavík.
- Thráinsson, H. (2001). *Íslensk setningafræði*. Course manuscript, University of Iceland, available at <https://notendur.hi.is//hoski/islensksetn.html>.
- Thráinsson, H. (2005). *Setningar. Handbók um setningafræði*. Íslensk tunga III. Almenna bókfélagið, Reykjavík.
- Thráinsson, H. (2007). *The Syntax of Icelandic*. Cambridge University Press, Cambridge.
- Truswell, R. (2004). *Attributive Adjectives and the Nominals they Modify*. Master's thesis, University of Oxford.
- Truswell, R. (2005). Non-restrictive adjective interpretation and association with focus. *Oxford Working Papers in Linguistics, Phonetics and Philology*, 9:133–154.
- Truswell, R. (2009). Attributive adjectives and nominal templates. *Linguistic Inquiry*, 40(3):525–533.

- Umbach, C. (2006). Non-restrictive modification and backgrounding. In *Proceedings of the Ninth Symposium on Logic and Language*, pages 152–159. Hungarian Academy of Sciences.
- Umbach, C. (2012). *Non-restrictive modification and evaluativity*. Paper presented at the Workshop on Semantic and Pragmatic Properties of (Non-)Restrictivity. University of Stuttgart, 19-20 March 2012.
- van Gelderen, E. and Lohndal, T. (2008). The position of adjectives and double definiteness. *Working Papers in Scandinavian Syntax*, 82:1–22.
- Vangsnes, Ø. A. (1999a). *A Configurational Approach to Interpretation*. Ms., University of Bergen.
- Vangsnes, Ø. A. (1999b). *'Identification' and the Role of Morphology in the Scandinavian Noun Phrase*. Ms., University of Bergen.
- Vangsnes, Ø. A. (2002). Icelandic expletive constructions and the distribution of subject types. In Svenonius, P., editor, *Subjects, Expletives, and the Extended Projection Principle*, pages 43–69. Oxford University Press, Oxford.
- Vangsnes, Ø. A. (2004). *Rolling up the Scandinavian Noun Phrase*. Ms., University of Tromsø.
- Vikner, C. and Jensen, P. A. (2002). A semantic analysis of the English genitive: Interaction of lexical and formal semantics. *Studia Linguistica*, 56(2):191–226.
- von Stechow, K. (2002). Specificity and definiteness in sentence and discourse structure. *Journal of Semantics*, 19(3):245–274.
- Wiltschko, M. (2014). *The Universal Structure of Categories: Towards a Formal Typology*. Cambridge University Press, Cambridge.
- Zamparelli, R. (2000). *Layers in the determiner phrase*. Outstanding dissertations in linguistics. Garland, New York.