

# Study of Refrigerants for Cold Climate Heat Pump Operations



H. Khawaja, E. Brodal, S. Jackson  
 UIT The Arctic University of Norway, Tromsø, Norway

## Abstract

The paper focuses on study of refrigerants for heat pump operations in cold climatic conditions. In this work, we have calculated the coefficient of performance (COP) for a heat pump cycle in the extreme temperatures conditions such as observed in an arctic environment. For the study, climatic data from Karasjok (69°28' 55" N 25°6' 18"E) is used as a test case (eKLIMA, 2014). Karasjok is located in Finnmark county of Norway. The refrigerants included in this study are R134a (Tetrafluoroethane), R22 (variants of Chlorofluoropropane), R290 (Propane), R404a (mixture of R125, R143a and R134a), R410a (mixture of R34 and R125), R717 (Ammonia) and R744 (Carbondioxide). The evaluated heat pump is based on single stage process that includes a compressor, a heat exchanger, an expansion valve and a condenser. For study, adiabatic efficiency of compressor is varied between 70-90 %. For heat exchanger and condenser a temperature difference of minimum 5 °C from surroundings is considered for their effective performances. For refrigerant such as R744, transcritical process is considered for the evaluation of COP. Analysis is performed in MATLAB® using the data for refrigerants from ASHRAE (CoolProp MATLAB® system libraries). In addition to the performance evaluations, a summary of other important selection factors including environmental concerns is presented. Conclusions are drawn based on the COP values from refrigerants for the heat pump operations.

## The Effect of Ambient Temperature on Performance

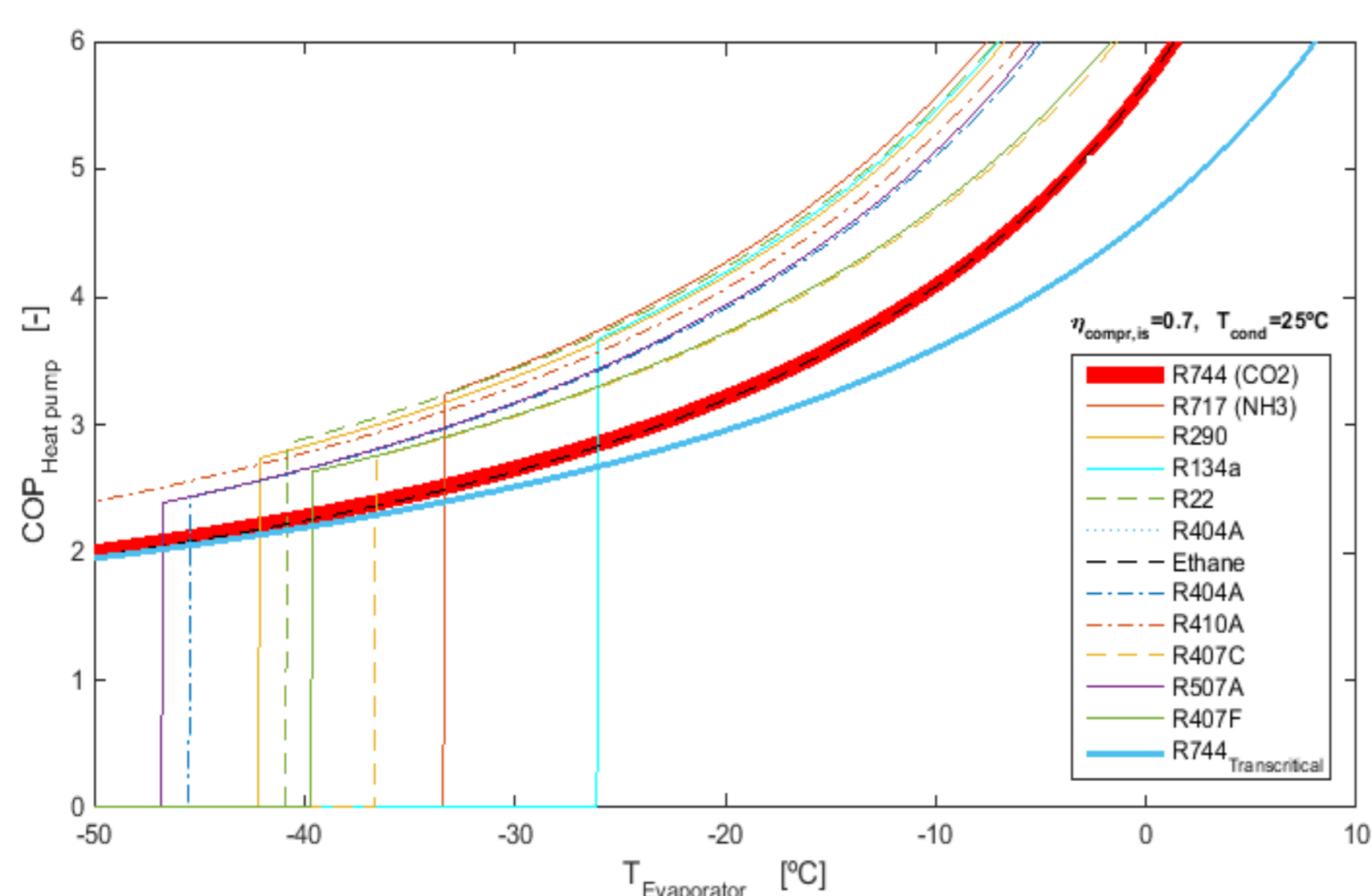

## Heat Pump Cycle of Carbon dioxide

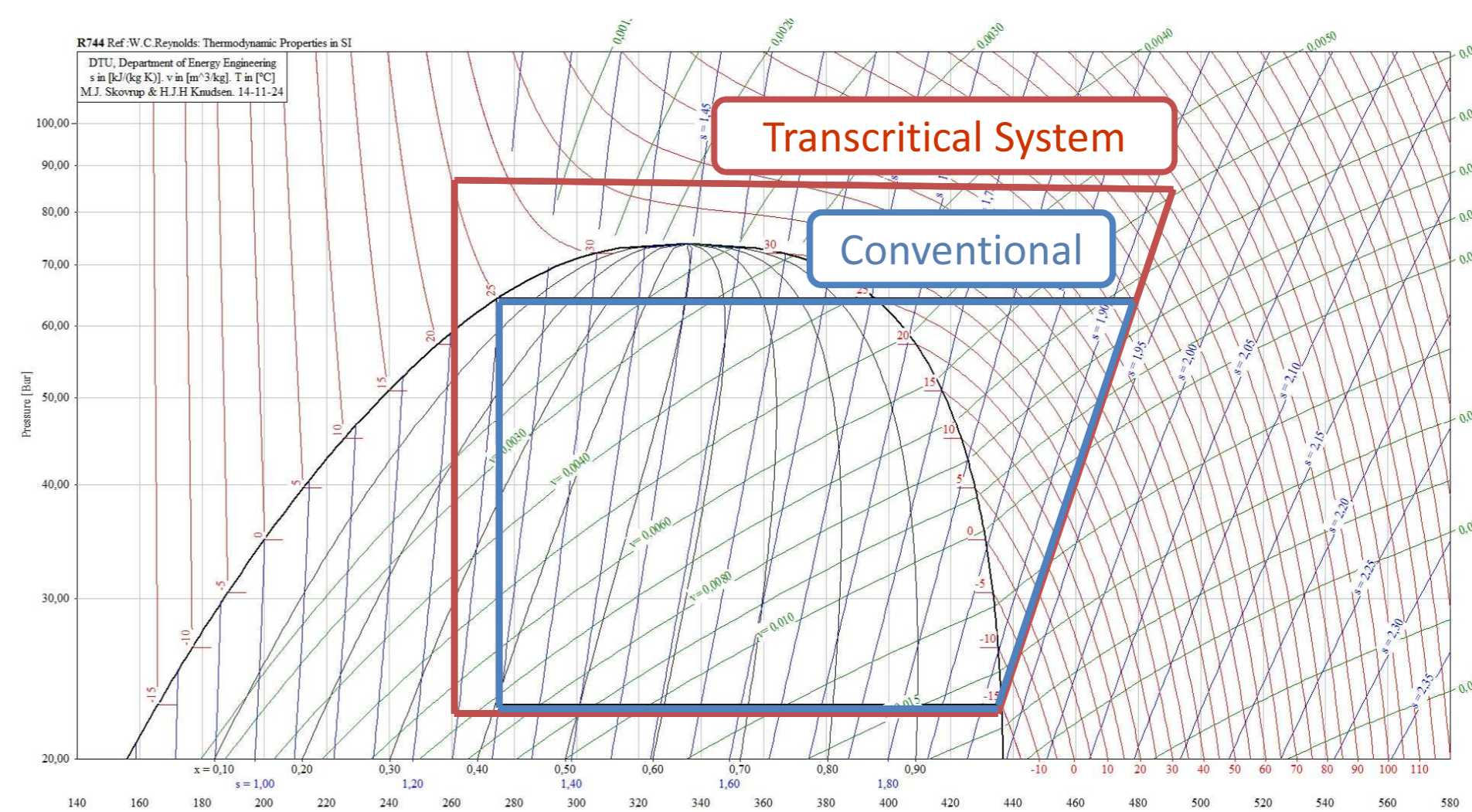

## The Effect of Design on Performance

To make a comprehensive comparison of performance a range of factors need to be considered:

- Refrigerant properties
- Machinery efficiency
- Exchanger area
- Ejector performance

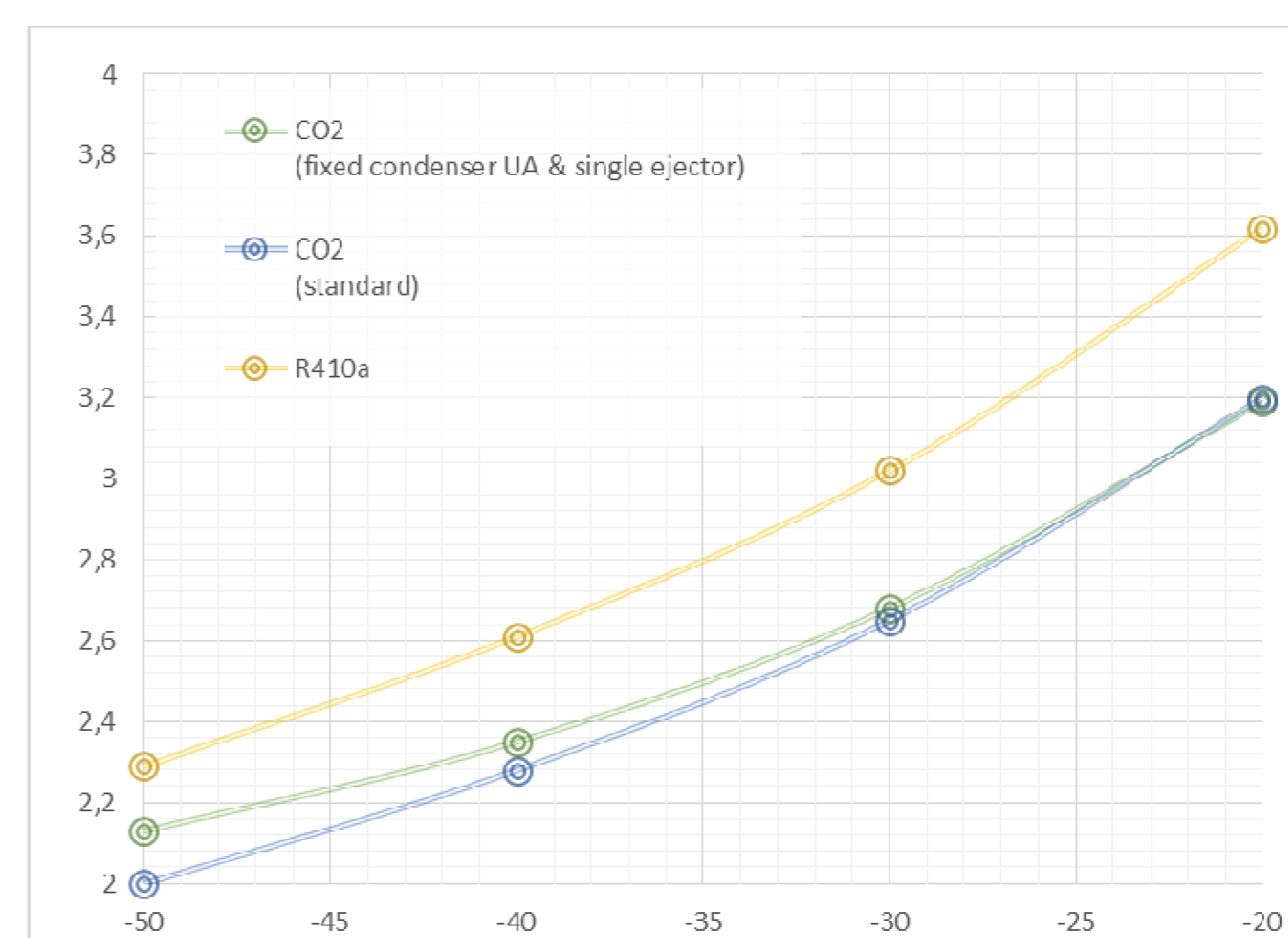
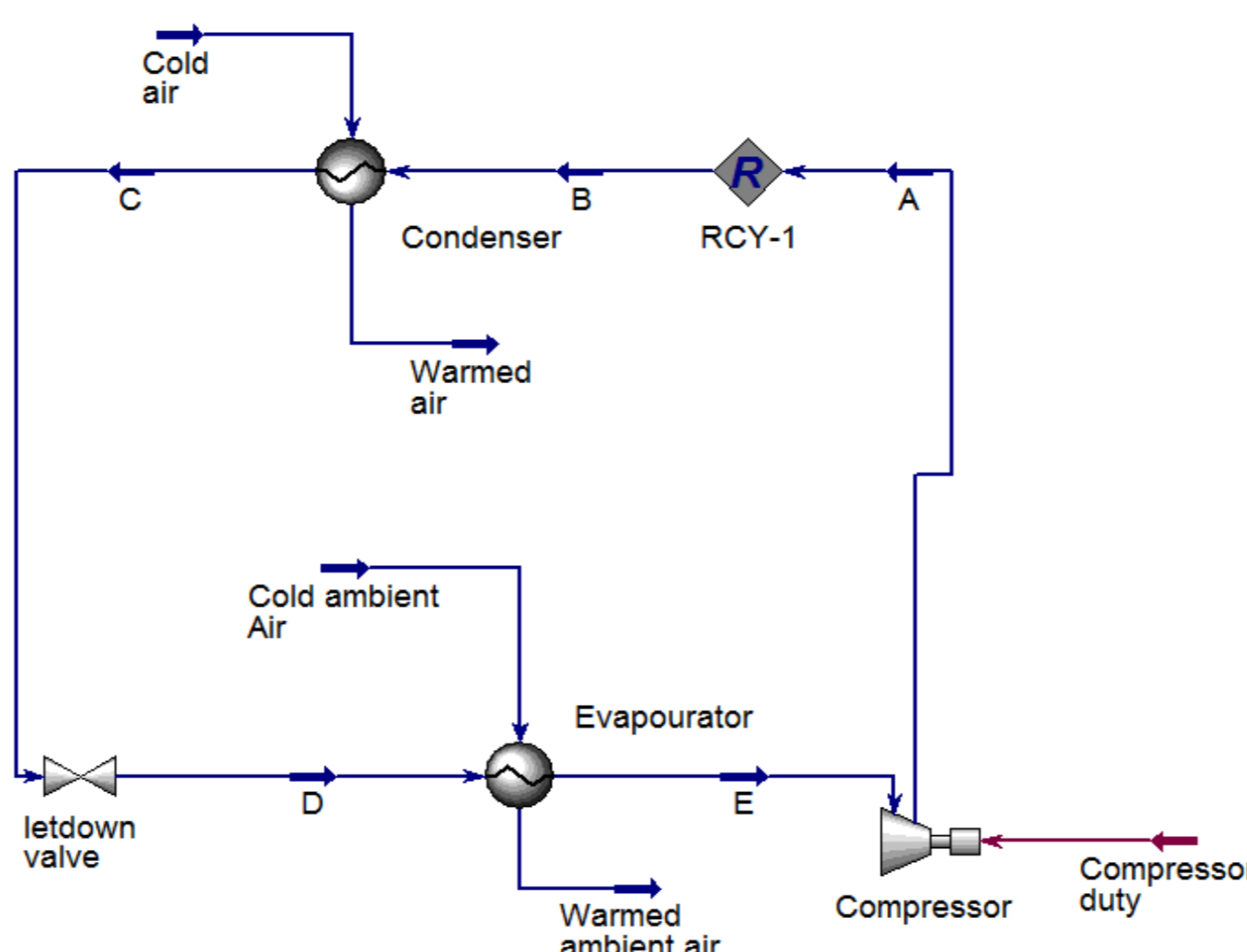

## Conclusion

Initial results indicate that significant improvements can be made relative to conventional refrigerants when design factors are taken into account.

## Future Work

The work can be extended to multi-stage refrigeration processes. The performance of CO2 refrigeration cycle can also be improved with the addition of multi-ejector systems.

## Contact

H. Khawaja

Assoc. Professor,  
 University of Tromsø,  
 Tromsø, Norway

E-mail:  
 hassan.a.khawaja@uit.no