

Risk-Based Spare Part Planning

Uncertainties and Operational Conditions

Master Thesis by

Yonas Zewdu Ayele

Thesis submitted in fulfillment of
the requirements for the degree of
MASTER OF SCIENCE
(M.Sc.)

**UNIVERSITY OF
TROMSØ UiT**



Faculty of Science and Technology
Department of Engineering and Safety
2013

University of Tromsø
N-9037 Tromsø
NORWAY
www.uit.no

©2013 Yonas Zewdu Ayele
All rights reserved

Abstract

Estimates which indicate a large share of the world's undiscovered oil and gas resources is to be found in the Arctic areas and the increasing demand for energy are important reasons for the growing interest in the High North region. As the offshore industry expands into the High North, system failures associated with these projects is expected to increase significantly. Hence, the quest for effective maintenance and maintenance support services are increased. However, the demanding physical conditions of the Arctic, the remote location, and the uncertainty from various sources are expected to increase the challenges related to the spare part planning, especially the transportation of spare parts.

The aim of this thesis is to study, review, and propose a model for risk-based spare part planning, especially for spare part transportation, considering the effect of operational conditions. Furthermore, the concept of both static and dynamic transportation networks is used to calculate the mean spare part transportation time and spare part deliverability. The application of the static model is demonstrated by a case study.

In this thesis, the theoretical framework chapter covers a brief survey of spare part planning, risk-based approaches, risk assessment methods, and application of risk analysis to spare parts planning. Then, types and sources of uncertainties, factors affecting spare part planning and spare part forecasting methods are reviewed. Afterward, a static model is developed for spare part transportation by considering the operating conditions of the Arctic region. The model is based on the concept of the transportation block diagram. A case study for the oil & gas (O & G) industry is presented to demonstrate how the proposed model can be applied. Furthermore, a dynamic model for spare part transportation is also developed. In this model, the factors which provide dynamic behavior of a spare part transportation network such as season (months) of the year (i.e. to transport the spare part), and criticality of the spare part are modeled.

The results obtained from data analysis showed that operational conditions of the Arctic region leads to approximately 20% extended delay's during the winter season, when we transport the spare part from the southwestern Norway to the northern Norway. Hence, any decision about the spare parts planning, especially the transportation of spare parts in the Arctic region must consider the effects of the operational conditions of the region.

Keywords: Spare part, Transportation, Block diagram, Deliverability, Dynamic network, Arctic, Risk-based, Operational environment, Uncertainties

Acknowledgements

Standing on the Shoulders of the Giants...

Isaac Newton used to say, in his letters, if I have seen any further, it is by standing on the shoulders of my giants. My gratitude and deepest appreciation go to all of my giants who have helped and inspired me during my studies.

I praised God for the wisdom and perseverance that he has been bestowed upon me during this thesis, and indeed, throughout my life: “The Lord God is my strength, and he will make my feet like hinds' feet, and he will make me to walk upon mine high places.” (Habakkuk 3:19).

I wish to express my gratitude to my supervisor, Associate Professor Abbas Barabadi, who literally pushed me to my limits and have confidence in me. And also for introducing me to the research area, and for providing me with all the necessary amenities and continuous support during this study. I would like to thank my co-advisor, Professor Javad Barabady, for his valuable guidance and helpful discussions for improvements in the thesis. I also want to thank Tor Schive for the guidance, and supportive discussions during my studies.

I want to express my deep and heartfelt gratitude ***to the biggest of all the giants - my mother***, Zafu Solomon, and ***my father***, Zewdu Ayele, for their unflagging love, prayers, encouragements and inconceivable support throughout my entire life. To restate Abraham Lincoln words: All that I am or ever hope to be, ***I owe to my angel mother***. Alongside, I cannot thank enough to my beloved sister's, Selenat and Haimanot, and my brother's, Wondwosen and Robel.

I would like to express my thankfulness to my ‘brother’ Yonas Zegay and my ‘sister’ Hiwot Amanuel, and also for their lovely kids, Simona and Isaac, for their support and hospitality during my stay in Norway. Without your support and encouragements, I could not have finished this work.

Last, but not least, I would like to thank to all of my friends in Tromsø, for their friendship, love, support, patience, and everything. You guys are wonderful and thank you so much.

Yonas Zewdu Ayele,

Tromsø, Norway

Contents

Abstract.....	iii
Acknowledgments.....	v
Contents.....	vii
List of appended papers.....	ix
Notation and Abbreviations.....	x
Basic Definitions.....	xi
List of Figures.....	xiii
List of Tables.....	xiv
Part I – Main Thesis.....	1
1. Introduction.....	2
1.1 Problem Statement.....	5
1.2 Research Questions.....	7
1.3 Research Purpose and Objective.....	8
1.4 Limitations of the Research.....	8
1.5 Research Outline.....	9
2. Research Methodology.....	11
2.1 Research Purpose.....	12
2.2 Research Approach.....	13
2.3 Research Strategy.....	15
2.4 Data Collection.....	16
2.5 Data Analysis.....	16
2.6 Reliability and Validity.....	17
3. Theoretical Framework – Basic Concepts.....	18
3.1 Introduction.....	18
3.2 Spare Parts Planning.....	19
3.3 Reliability Performance.....	25
3.4 Maintainability Performance.....	26
3.5 Maintenance Support Performance.....	27
3.6 Spare Part Demand Forecasting.....	27
3.6.1 Renewal Process Model.....	28
3.6.2 Poisson Process Model.....	30
3.6.3. Bayesian Model.....	30

3.7 Risk Assessment Methods.....	31
3.7.1 Overview of Risk Assessment Technique.....	32
4. Results and Discussion.....	35
4.1 Factors Affecting Spare Part Planning and Sources of Uncertainties in the Arctic Region.....	35
4.1.1 Factors Affecting Spare Part Planning in the Arctic Region.....	35
4.1.1.1 Environmental Factors.....	36
4.1.1.2 Geographical Location Factors.....	36
4.1.1.3 Cost Factors.....	37
4.1.1.4 Urgency Level Factors.....	37
4.1.1.5 Other Important Factors.....	38
4.1.2 Types and Sources of Uncertainties in the Arctic Region	38
4.2 The Risk Analysis and Reduction Measures for Spare Part Planning. . .	42
4.3 Spare Part Transportation Management in the Arctic Region.....	49
4.3.1 Spare Part Transportation Block Diagram	45
4.3.2 Dynamic Spare Part Transportation Model.....	48
4.4 Summary of Appended Papers.....	50
5. Research Contribution.....	52
6. Suggestions for further research.....	53
7. References.....	54

Part II – Appended Paper.....58

Paper I - Spare Part Transportation Management in the High North.....	59
Paper II - Dynamic Spare Part Transportation Block Diagram.....	77

List of Appended Papers

- Paper I Ayele, Y.Z., Barabadi, A. Markeset, T. (2012). Spare part Transportation Management in the High North, *Submitted to International Conferences on Port and Ocean Engineering under Arctic Conditions (POAC2013)*.
- Paper II Ayele, Y.Z., Barabadi, A. (2013). Spare Part Dynamic Transportation Block Diagram. *To be Submitted to International Journal*.

Notation and Abbreviations

MTBF	Mean Time Between Failure
MTTR	Mean Time To Repair
RAMS	Reliability, Availability, Maintainability, and Safety
TBF	Time Between Failure
TTR	Time To Repair
MDT	Mean Down Time
<i>Cdf</i>	Cumulative density function
<i>Pdf</i>	Probability density function
PHM	Proportional Hazard Model

Basic Definitions

Reliability - The ability of an item to perform a required function under given conditions for a given time interval (IEC, 191-02-06).

Availability - The ability of an item to be in a state to perform a required function under given conditions at a given instant of time or over a given time interval, assuming that the required external resources are provided (IEC, 191-02-05).

Maintainability - The probability that a failed system is restored to a functioning state, in any given time and in a given environment using the given procedures and resources (Leitch, 1995).

Maintenance - The combination of all technical and administrative actions, including supervision actions, intended to retain an item in, or restore it to, a state in which it can perform a required function (IEC,191-07-01).

Mean Time Between Failures - The expectation of the time to failure (IEC, 191-12-07).

Mean Time To Repair - The expectation of the time to restoration (IEC, 191-13-08).

Repairable System - A repairable system for this thesis is defined as a system that fails but is not replaced for every failure.

Covariate - A quantification of factors influencing the reliability characteristics (Kumar and Klefsjo, 1994).

Failure - The termination of the ability of an item to perform a required function (IEC, 191-04-01).

Fault - The state of an item characterized by inability to perform a required function, excluding the inability during preventive maintenance or other planned actions, or due to lack of external resources (IEC, 191-05-01).

Error - A discrepancy between a computed, observed or measured value or condition and the true, specified or theoretically correct value or condition (IEC, 191-05-24).

Operational conditions - Can be defined as the premise of which the equipment is exposed to in the place it is operating, this can be; temperature, icing, dust, wind, skill crew, material, design etc.

Lead time - is the latency (the delay) between the initiation and execution of a process (Meredith and Mantel Jr, 2011).

List of Figures

Figure 1.1: Research Framework.....	9
Figure 3.1: Spare part planning as part of product support.....	20
Figure 3.2: Evaluation of spare parts.....	22
Figure 3.3: Impact of a reliability program on life cycle cost (LCC).....	25
Figure 3.4: Mean Down Time.....	27
Figure 3.5: Proportionate risk assessment.....	32
Figure 4.1: Cause and effect diagram for sources of uncertainties.....	41
Figure 4.2: Risk analysis options.....	42
Figure 4.3: Risk management process.....	45
Figure 4.4: Combined spare part transportation network.....	46

List of Tables

Table 2.1: Different kinds of research purposes.....	12
Table 3.1: Criticality matrix for spare parts.....	23
Table 3.2: Risk matrix for spare parts storage location.....	24
Table 4.1: Consequence matrix.....	38
Table 4.2: The relations between the papers, the main thesis and the research questions.....	50

Part I – Main Thesis

1. Introduction

Estimates which indicate a large share of the world's undiscovered oil and gas resources is to be found in the Arctic areas and the increasing demand for energy are important reasons for the growing interest in the High North region. In order to explore the oil and gas reserves and to perform more efficient offshore operations in the Arctic region: technological advances continue to be made in the offshore oil and gas exploration, drilling and production (Burton and Feijo, 2008). As a result, offshore facilities are being designed incorporating non-traditional arrangements and unconventional technology (Burton and Feijo, 2008). With the increased mechanization and complexity in process plant, there is a rise in the number of component failure scenarios (Hassan et al., 2012). Furthermore, these advanced production systems are susceptible to failures in ways we might not have conceived.

As the offshore industry expands into the High North: deeper water, remote locations, harsher environments, and a complex operational condition the hazards, environmental degradation, equipment damages, workplace injuries and system failures associated with these projects is expected to increase significantly compared to the well-established practices of exploration and production in the North sea (Gudmestad et al., 2007, Barabadi et al., 2009, Gudmestad and Strass, 1994, Kayrbekova et al., 2011). Furthermore, oil and gas (O & G) production activities in the Arctic region could face unforeseen challenges. These challenges could be due to new and advanced technological innovations related to the production systems, 'untested' knowledge regarding to risk management of the major hazards, little experience in maintenance support services, and little expertise on the use of international and/or Norwegian regulations and standards in the Arctic region.

In order to meet the availability target and to reduce downtime, effective maintenance and maintenance support services are undoubtedly important. Maintenance and maintenance support activity can act as a barrier to reduce the risk related to failures and risks due to un-deliverability of spare part (within planned delivery time). Preventive maintenance, as an active barrier, can reduce the probability of failure, and corrective maintenance, being a passive barrier, can reduce the consequence of failures. In fact, maintenance plays a pivotal role in managing risks at an industrial site, and it is important that the right risk assessment tools should be applied to capture and evaluate the hazards at hand to allow a functional risk-based approach (Rasche and Wooley, 2000).

Efficient product support and spare part planning are important prerequisites for an effective maintenance program. They can have a significant economic impact, by helping to maintain the reliability of the system, by reducing the downtime, and by facilitating the maintenance process. Hence, modifying and/or developing new and emerging (smart) maintenance support services, by considering the effect of operating conditions of the Arctic region, can offer solutions to fill the gaps which exist between the present practices and future needs. It can also offer solutions to obsolescence issues, which arises due to technological advances, and offset the escalating costs of maintenance. This can be achieved by evaluating the efficiency of current practices, by identifying the shortcomings of current methodologies, and by exploring the future needs. In addition, it is possible to make use of ICT (Information and Communication Technology), and automation & remote operation for support service in remote areas, to reduce workforce (expertise) and logistic requirements.

For a long time, the conventional spare part planning strategies have been preoccupied with avoiding stock-outs to maximize the availability and reliability of the systems (Ghobbar and Friend, 2002, Kumar et al., 2000b). However, optimizing the reliability of the system and/or selecting the more reliable system does not necessarily mean selecting the system with the smaller losses from failures (Todinov, 2007). Furthermore, the consequences of system failures and due to un-deliverability of the spare part within the planned delivery time, in the Arctic region might be disastrous.

For O& G production systems for example, major components of the losses from failures are the amount of lost production time, the cost of mobilization of resources and intervention, the cost of repair or replacement, lost customers, warranty payments, insurance costs, idle manpower cost and so on. (Todinov, 2007). In addition, a critical failure in deep- water O & G production system, in particular, entails long downtimes and extremely high costs of lost production and intervention for repair (Todinov, 2007). Furthermore, due to the Arctic sensitive environment to disruption, on one hand, but harsh and unforgiving on the other the environmental impacts can take longer to heal and cost more to remediate (Paulin, 2012).

Hence, in order to reduce the risks due to stock-out and un-deliverability of the spare parts, spare part planning should necessarily be risk-based, linked with the consequences of the failure and the un-deliverability of the spare part (within the planned delivery time). Minimizing the overall risk profile and increasing the supportability performance of these complex projects is the main objective of risk-based spare part planning. Risk-based approaches encourage a deeper understanding of the risks associated with system failures and un-deliverability of the critical spare part, than is possible under a generic approaches (Burton and Feijo, 2008). It can also help to ensure spare parts availability by suggesting effective risk reduction measures, by systematically prioritizing the spare parts corresponding to their criticality, and by forecasting the spare part demand based on the failure history or failure rate of the components (Hassan et al., 2012). In addition, by analyzing, identifying & quantifying the risks involved in the spare part planning, the industry can take appropriate measures to overcome those risks. Furthermore, it could improve system reliability & reduces losses from failure, in general, it could maximize the overall economic benefits.

1.1. Problem Statement

Offshore field development, especially in the Arctic region, is a complex activity involving uncertainties from a wide range of sources (spe.org, 2003, DNV, 2001). Sources of the uncertainty can be broadly grouped into the followings: technical, financial, organizational, contractual and/or procurement, sub-contractual, political and/or cultural (Umar, 2010). Due to the Arctic operational environmental factors such as large variations in temperature during a short period of time, sudden wind increase and large changes in wind direction, icing, snow, and inadequate weather forecasting, it's expected that the uncertainty will be magnified and the risk involved will be much higher than the North Sea (Barabadi et al., 2009). These uncertainties could have direct effects in the spare part demand forecasting, in estimating mean spare part transportation time, in general, they can affect maintenance support services, especially the spare part planning.

As part of spare part planning, the number of the required spare parts can be estimated, after identifying the reliability performance of the system and the failure rate of the item (Kumar et al., 2000b, Barabadi, 2012); in addition, spare part transportation time can also be estimated. In general, the reliability of a system is obtained from the historical data of the system, from a similarly functioning system data, or from an expert judgment (Kalbfleisch and Ross, 2002). Cumulative uncertainties due to few available data related to the reliability of the system and the operational condition of the Arctic region increased the risk involved and makes it difficult to get the exact values of the reliability parameters. This can cause significant challenges in the spare part planning and execution process. Hence, uncertainty and risk analysis must be integrated with the spare part planning: in order to reduce the consequences of the failure, to reduce the extended down-time (due to un-deliverability of critical spare part within the planned delivery time), and to ensure the spare part availability requirements.

In general, most of the challenges related to spare parts planning arises due to lack of deep insight into spare part needs under varying operating conditions, and the sporadic nature of component's failure and corresponding random demand of spare parts (Markeset, 2011, Hassan et al., 2012). Furthermore, uncertainties related to the transportation of spare parts in the Arctic region, are other challenges. The need to measure all types of operational risk is crucial to revealing the magnitude of existing risk and implementing appropriate risk management procedures (Todinov, 2007). In addition to the operational risks, there are additional risks due to the unforeseen challenges in the Arctic region. In order to include these additional risks, the probabilistic estimation of unforeseen uncertainties due to the unforeseen challenges in the Arctic region should be carried out. Furthermore, even if the individual criticality failures are associated with relatively small losses, in the long run, particularly if such failures occur with high frequency, the amount of total accumulated loss can be very large (Todinov, 2007).

Hence, effective spare part planning which considers the risks involved and uncertainties, can act as an efficient risk reduction measure, and also can reduce the probability and consequence of the failure. One way to reduce the risk level is by applying minimum lead time procurement strategy (Hassan et al., 2012). This could minimize the quantity of procured spare parts and the risk level (Hassan et al., 2012). In minimum lead time procurement strategy, it is very important to predict the transportation time of the spare parts precisely. This could help to avoid extended down-time and stock-outs caused by the un-deliverability of the spare parts. However, the long-distance location of manufacturers and providers of industrial services and skilled manpower, insufficient infrastructure together with the remote geographical location of the Arctic region, makes it demanding task, both to estimate the mean transportation time and to predict the probability of having the spare part on-site.

In order to tackle the above mentioned problems, we can make use of risk-based spare part planning. The concept of risk takes into account, not only the probability of un-deliverability of the spare part, but also the consequences of the un-deliverability.

The consequences can be in terms of HSE costs, lost production & profits, idle manpower costs, and environmental cleanup costs. Such a plan ensures that planning effort is targeted appropriately to optimize costs and benefits, and provides an auditable demonstration that this has been done with due diligence (Eckold and Adamson, 2012). In addition, risk-based approach will help to optimize the spare part logistic - based on the cost of the spare part, ordering cost, stockholding cost, stock-out cost, and the cost of un-deliverability. Furthermore, risk-based approach provides an insight into spare part needs right from the stage of 'perception' (Markeset, 2011). In addition, a risk-based approach is particularly well suited to a technology driven industry, such as O & G projects in the Arctic region where offshore facilities are being created well in advance of the development of prescriptive or performance-based regulations (Burton and Feijo, 2008).

1.2. Research Questions

Based on the above discussion, the main problem of the research study is to identify the potential sources of uncertainties and risks involved, and to analyze the effects of operational conditions on the spare part planning, especially on spare part transportation. The following research questions are posed on the basis of the research problem:

1. What are the main factors affecting spare part planning and sources of uncertainties in the spare part planning, in the Arctic region?
2. How can the risk involved in the spare part planning is identified and quantified, considering the effect of operational conditions?
3. How can the transportation time for spare parts can be estimated, and how can the dynamic operational conditions of the Arctic region can affect the spare parts planning, especially the spare part transportation ?

1.3. Research Purpose and Objectives

The purpose of this research is to study, analyze and propose a model for risk-based spare part planning, especially for spare part transportation, considering the effect of operational conditions. The main objective of the study is to develop model for spare part transportation, in order minimize the overall risk profile and to ensure that the right spare part and resources are in the right place at the right time, in the hands of the right person. More specifically, the sub-objectives of the research are:

- To review and discuss the main factors affecting spare part planning and sources of uncertainty in the spare part planning under the Arctic conditions.
- To review and analyze the risk assessment and reduction measures for the spare part planning by taking into consideration the effect of the Arctic operational conditions.
- To develop a static and dynamic model, in order to predict spare part transportation time by considering the effect of the Arctic conditions.

1.4. Limitation of the Research

During this study the effect of Arctic operational conditions on the transportation of spare part is studied and both dynamic and static spare part transportation models are developed. However, for the case study in appending paper I, the mode of transportation was only ship-cargo, air-cargo, truck-cargo, and helicopter. Furthermore, in order to generalize the result and finding to theoretical proposition, the proposed model in the appending paper II must be tested through replication of findings in more case studies.

1.5. Research Outline

The structure of the thesis is presented in Figure 1.1. The first chapter, introduction, starts with a description of the background and research problems. The rest of the thesis is organized as follows: Chapter 2, research methodology, presents a description of the research methodologies, approaches, data collection and validation methods.

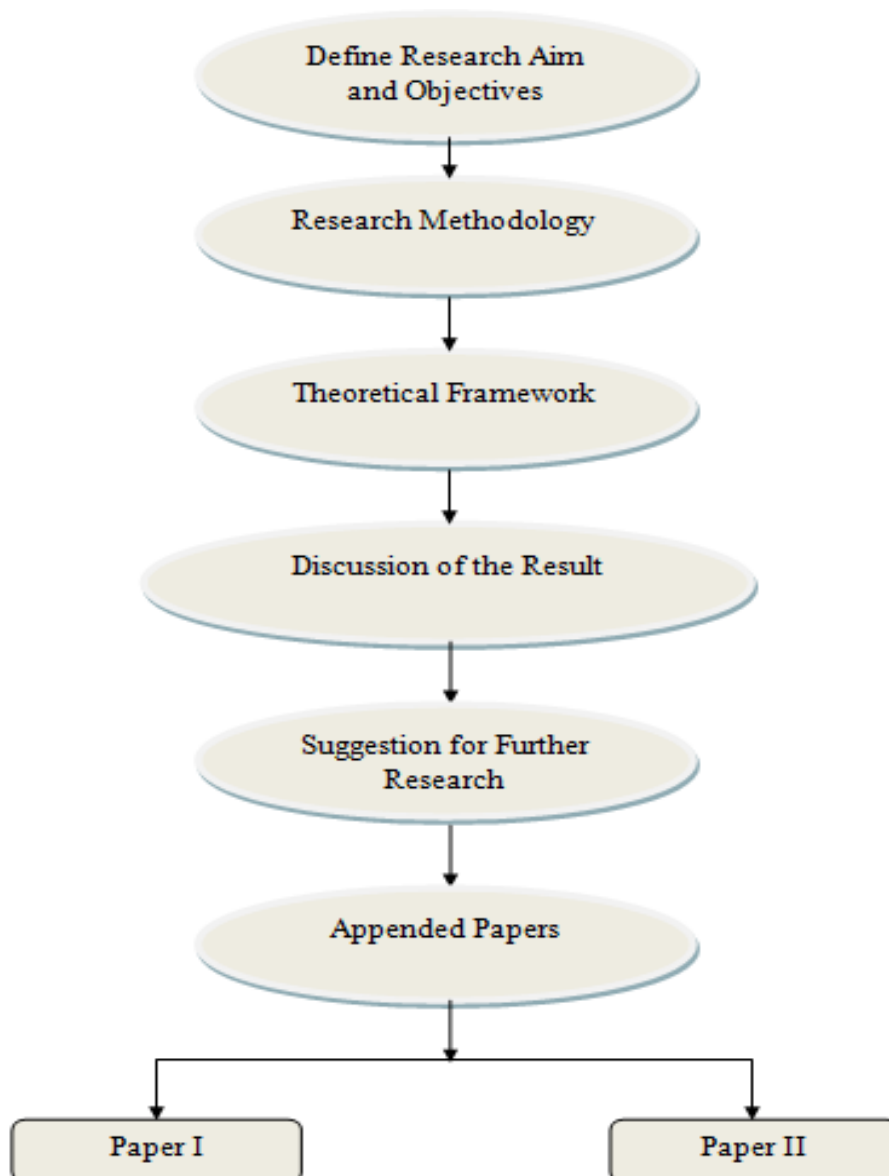

Figure 1.1: Research Framework

Chapter 3, theoretical framework, briefly covers aspects of spare part planning, literature reviews of risk-based approaches, risk assessment methods. Chapter 4, presents the discussion of results, findings, interpretation of the results from the case study and draw conclusion. Chapter 5, presents research contributions. Chapter 6, summarizes suggestions for further research.

2. Research Methodology

This chapter provides a brief description of the research methodology, approaches, and methods for data collection and data analysis which are used in this study in order to achieve the research objectives. Research has been defined in a number of different ways. A broad definition of research is given by Martyn Shuttleworth - "In the broadest sense of the word, the definition of research includes any gathering of data, information and facts for the advancement of knowledge"(Shuttleworth, 2008). Another definition of research is given by Creswell (2008) who states - "Research is a process of steps used to collect and analyze information to increase our understanding of a topic or issue". It consists of three steps: Pose a question, collect data to answer the question, and present an answer to the question (Creswell, 2008). The research methodology is the link between thinking and evidence (Sumser, 2000).

Research can broadly be classified into two: basic research and applied research. Basic research is carried out to understand the fundamental nature of a subject or topic which can generate a new idea or fundamental knowledge (Young and Schmid, 1966). Applied research conducts a study to address a specific concern or to offer solutions to a problem (Young and Schmid, 1966). Applied research usually means a quick, small-scale study that provides practical results that people can use in the short term (Neuman, 2003). The most and crucial step to do a research, is to choose a clear methodology.

2.1. Research Purpose

Research involves systematic investigation of phenomena in order to, broadly, gathers information and/or test theory. Gathering information can be for exploratory or descriptive purposes, whilst theory-testing could be for explanatory or predictive purposes (Neill, 2008).

Firstly, a researcher must decide what type of research is to be conducted. Research can be conceptualized as exhibiting one or more of the following four purposes (Neill, 2008): Exploratory such as discovering, uncovering, and exploring; Descriptive such as summarizing, gathering information, and mapping; Explanatory such as testing and understanding causal relations; Predictive such as predict what might happen in various scenarios. Table 2.1, shows summary of different types of research purposes.

Table 2.1: Different kinds of research purposes (Neuman, 2003)

Exploratory	Descriptive	Explanatory
<ul style="list-style-type: none"> - Become familiar with the basic facts, setting, and concerns. - Create a general mental picture of conditions - Formulate and focus questions for future research - Generate new ideas, conjectures, or hypotheses - Determine the feasibility of conducting research - Develop techniques for measuring and locating failure data 	<ul style="list-style-type: none"> - Provide a detailed, highly accurate picture - Locate new data that contradict past data - Create a set of categories or classify types - Clarify a sequence of steps or stages - Document a casual process of mechanism - Report on the background or context of a situation 	<ul style="list-style-type: none"> - Test a theory's predictions or principle - Elaborate and enrich a theory's explanation - Extend a theory to new issues or topics - Support or refute an explanation or prediction - Link issues or topics with a general principle - Determine which of several explanations is best

This research tries to address risk-based approaches for spare part planning, especially for spare part transportation and it can be categorized as applied research. The methodologies used in this research are both descriptive and exploratory. The purpose of this research is to describe methodologies for risk-based in the spare part planning, considering the effect of operational conditions. In addition, to describe the methodologies of identifying and quantifying uncertainties and risk-involved in the spare part planning taking into consideration the operational conditions. Furthermore, the research tries to model the spare part transportation, in order to estimate mean spare part transportation time and the probability of deliverability.

2.2. Research Approach

Research approach refers to the approach or the methodology that has been adopted to conduct the research (Blurtit.com, 2012). It basically involves the selection of research questions, the conceptual framework that has to be adopted, the selection of appropriate research method such as primary research, secondary research etc (Blurtit.com, 2012).

Research approach can be one or a mix of the following four methods: inductive, deductive, abductive, and retroductive. The aim of inductive approach is to establish descriptions of characteristics and patterns, and the approach starts by collecting data on characteristics and/or patterns, and finishes by relating these to the research questions (Blaikie, 2009). The aim of deductive approach is to test theories, to eliminate false ones and corroborate the survivor. It starts by constructing a theory and deduce hypotheses and ends by testing hypotheses by matching them with data explanation in that context (Blaikie, 2009). Abductive approach can be seen as a combination of deductive and inductive approach. In the abductive approach, research can be started with a deductive approach, and an empirical collection of data based on a theoretical framework can be made; this can then continue with the inductive approach in which theories based on the previously collected empirical data are developed (Neuman, 2003). To discover underlying mechanisms and to explain observed regularities are the main aims of reproductive approach. In general, abductive creates, deductive explains, and inductive verifies (Neuman, 2003).

Research approach can be quantitative, qualitative and/or mixed. In simple terms, quantitative research refers to the systematic empirical investigation of phenomena via statistical, mathematical or computational techniques (Given, 2008) whereas qualitative research adopts questioning and verbal analysis (Sullivan, 2001). Mixed research method, or multi-methodology, is an approach to professional research that combines the collection and analysis of quantitative and qualitative data (Creswell et al., 2004). Mixed research uses both deductive and inductive methods, obtains both quantitative and qualitative data, attempts to corroborate and complement findings, and takes a balanced approach to research i.e. it has complementary strengths and non-overlapping weaknesses (Sagepub, 2012).

In this research both deductive and inductive research approaches have been applied. The research started as a deductive approach with a literature review to gain a deeper understanding about risk-based approaches, sources and types of uncertainties, risk assessment methods, and application of risk analysis to spare parts planning. In addition, the effects of operational conditions on spare part transportation are covered in the literature review part. Results from the literature review shows that the conventional spare part planning has been preoccupied with supporting the system, to help maximizing the reliability of systems not with reducing losses from failures (Todinov, 2007, Kumar et al., 2000b, Ghobbar and Friend, 2002). In addition, most of the literature didn't consider the effects of the Arctic operational conditions on the spare part transportation, in general, on the spare part planning. Furthermore, the demanding physical conditions of the Arctic, the remote location, and the uncertainty (related to the travel time, and demand forecasting) can increase the challenges related to the spare parts planning in the region. As a result, the conventional methods must be modified to take risk analysis as a key component for the estimation of transportation time and prediction of spare part demand on the system in the Arctic region. Deductive approach is applied to develop a risk-based spare part planning, whereas induction approach is applied to quantify mean time to delivery and the probability of deliverability of the spare part .

Both qualitative and quantitative research methodologies have been applied in this research. Quantitative research deals with calculation of spare part transportation time, and probabilistic estimation of spare part demand. Qualitative analysis deals with a survey of spare part planning and risk-based methodologies for production facilities in the Arctic region. As the research study tries to mix the best of qualitative and quantitative methods, and uses both deductive and inductive methods, it can be characterized as having an abductive- mixed research approach.

2.3. Research Strategy

A research strategy is a procedure for achieving a particular intermediary research objective - such as sampling, data collection, or data analysis (Creswell, 2008). Thus, we can have sampling strategies or data analysis strategies. The use of multiple strategies to enhance construct validity (a form of methodological triangulation) is now routinely advocated by most methodologists (Creswell, 2008). In short, mixing or integrating research strategies (qualitative and/or quantitative) in any and all research undertaking is now considered a common feature of all good research (Brannen, 2005). Due to the purpose of the study and the research questions, the selection of a research strategy mostly depends on which kind of information the researcher is looking for (Yin, 2008). Yin (2008) describes five different research strategies to apply when collecting and analyzing empirical evidence. These are: archival analysis, history, experiment, survey, and case study. Archival analysis and history strategies refer to the past conditions of the case under study (Yin, 2008). The rest of the strategies (experiments, surveys and case studies) usually refer to the present situation (Yin, 2008).

For this research study, case study research strategy is used in the appending paper I. Case study research excels at bringing us to an understanding of a complex issue or object and can extend experience or add strength to what is already known through previous research (Soy, 1997). Case studies emphasize detailed contextual analysis of a limited number of events or conditions and their relationships (Soy, 1997). Robert K. Yin defines the case study research method as an empirical inquiry that investigates a contemporary phenomenon within its real-life context; when the boundaries between phenomenon and context are not clearly evident; and in which multiple sources of evidence are used (Yin, 1984).

2.4. Data Collection

Within each one of the general research approaches, one or many data collection techniques may be used (Straub et al., 2004). Typically, a researcher will decide for one (or multiple) data collection techniques while considering its overall appropriateness to the research, along with other practical factors, such as: the expected quality of the collected data, estimated costs, predicted non-response rates, expected level of measurement errors, and length of the data collection period (Lyberg and Kasprzyk, 1991). It is of course possible that a given research question may not be satisfactorily studied because specific data collection techniques do not exist to collect the data needed to answer such a question (Kerlinger and Lee, 1986). The most popular data collection techniques include: surveys, secondary data sources or archival data, objective measures or tests, and interviews (Yin, 1984).

The data used in this study have been collected using different sources such as meetings and discussions with shipping agents, email requests, telephone conversations, and using Statens vegvesen route planner – a route planner developed by the Norwegian Public Roads Administration. Transportation times, distance between two transits, and average allowable speed are part of the collected data. Data sources are leading logistic companies, such as Johs. Sundfør AS, Nor Lines AS, SAS Cargo, and other freight forwarding companies, ship broker, and liner agencies.

2.5. Data Analysis

Data analysis usually involves inspecting, transforming, and modeling data with the goal of highlighting useful information, suggesting conclusions, and supporting decision making (Adèr, 2008). Data analysis can be divided into two: exploratory data analysis (EDA), and confirmatory data analysis (CDA) (Adèr, 2008). EDA focuses on discovering new features in the data and CDA on confirming or falsifying existing hypotheses (Adèr, 2008).

In this research the analysis of time to delivery (*TTD*) data for spare part transportation was carried out. In order to consider the effect of operational conditions on the spare part deliverability function, the data have been categorized into - two groups i.e for summer and winter season. Moreover, in order to obtain the spare part transportation deliverability, the common distributions have been used and spare parts transportation block diagram (STBD) is employed to obtain the network deliverability. Furthermore, in order to find the spare part deliverability function using the common groups in the first stage, some distributions such as normal, log-normal or Weibull was nominated for the data. In the next stage using some goodness of fit test, the best fit distribution of the data was found. Then the distribution parameter is calculated using available methods such as maximum likelihood (MLE) methods (Kumar et al., 2000a). In this thesis, Weibull ++8 distribution wizard is used as a tool to estimate the best fit distribution for the given time to delivery data (ReliaSoft, 2013). Then, by implementing the best fit distribution for the given data using MLE, mean time to delivery (*MTTD*) are estimated.

2.6. Reliability and Validity

The principles of validity and reliability are fundamental cornerstones of the research method (Shuttleworth, 2008). According to Neuman (2003) reliability means dependability or consistency. Reliability can be also defined as the extent to which a questionnaire, test, observation or any measurement procedure produces the same results on repeated trials (Miller, 2012). In short, it is the stability or consistency of scores over time or across raters (Miller, 2012). Validity is concerned with how well an idea about reality fits with the actual reality (Neuman, 2003). In general, there are two types of validity: internal and external validity.

To meet the reliability, the data and information used in this thesis are collected either from shipping agents, air-cargo companies, and reports or from OREDA databases. Furthermore, the sources of the data are available for recollection and reanalysis. However, in order to generalize the results and findings to the theoretical propositions, the proposed models must be tested through replication of findings in more case studies.

3. Theoretical Framework - Basic Concepts

Spare parts planning is a process that O & G industries used it to ensure that the right spare part and resources are at the right place (where the broken part is) at the right time and at the hand of the right person. DNV (2009) defines spare part management as ‘Spare part management is the planning, execution and control of all spare parts related activities, which are the provision, maintenance, stocking, deployment and discarding of spare parts, in accordance with corporate objectives and requirements’. There are a significant number of literatures about spare part planning, however, most of the literatures didn’t consider the operational conditions of the Arctic region. This literature review tries to include challenges on the spare part planning, due to operational conditions of the Arctic region. It also treats the basic methods of spare part demand forecasting, factors that affect spare part planning, risk assessment methods, types and sources of uncertainties .

3.1. Introduction

Prior to the world war II, mechanical systems were relatively simple in capability and complexity; and most portions of a system seldom failed and when they did were easily fixed (Utter and Utter, 2005). Due to technological advances, systems became more and more complex. This results in new and more complex failures that are more difficult to diagnose and harder to predict in advance. In other words, complexity created new problems, namely more capable but more fragile systems (Utter and Utter, 2005). From this evolving reality the disciplines of reliability and maintainability engineering are created (Utter and Utter, 2005).

Reliability and maintainability are not only an important part of the engineering design process but also necessary functions in the operational capability studies, repair and facility resourcing, inventory and spare parts requirement determinations, replacement decisions, and the establishment of preventive maintenance programs (Patra, 2007).

In the O & G industries, especially in the Arctic region, critical system down-time might be extremely costly and the consequences of the critical failures might be intolerable. As a result, the quest for effective and reliable maintenance support services increased significantly. In other word, supportability became the important backbone in assuring to have the highest overall production performance. However, when we plan to ensure availability of spare parts for breakdown replacement, there is always a tendency to overstock them at a substantial inventory cost (Sarker and Haque, 2000). This overstock is frequently interpreted as safety stock (Sarker and Haque, 2000). Furthermore, it is of a paramount importance that the required spare parts are on-site, upon demand, and cargo containing specialized and/or tailor-made equipment reaches on-site as fast as possible. However, the question that arises here is *how can we plan and manage the spare part inventory using available experience and data for the Arctic region – in order to reduce the consequences due to system failures and undeliverability (within planned delivery time) of the spare parts?* In order to answer the question, in this thesis, the concept of risk- based spare part planning are applied.

3.2. Spare Parts Planning

Spare parts planning and logistics is an aspect of product support management which influences the product life cycle cost (Ghodrati, 2005). The availability of spare parts upon demand decreases the production down-time and increases the utilization of the system/machine and consequently the profitability of the project (Ghodrati, 2005). In general, spare part planning must meet the requirements of the spare part business such as the high and/or sporadic spare parts needs in terms of quantity and demand patterns, different spare part dimension/ size, and the overall cost (this can include the cost of ordering/ replenishing/lost production/HSE and etc.).

Furthermore, the spare part, as an important part of product support, is vital to enhance maintenance support performance. The logistics and inventory levels of the spare parts are different depending on the spare part in question, and ordinary approaches used for stock control in manufacturing situations do not apply to spare parts (Fortuin and Martin, 1999). Figure 3.1 shows the relationship between system performance, the operating environment, and spare parts planning as part of product support.

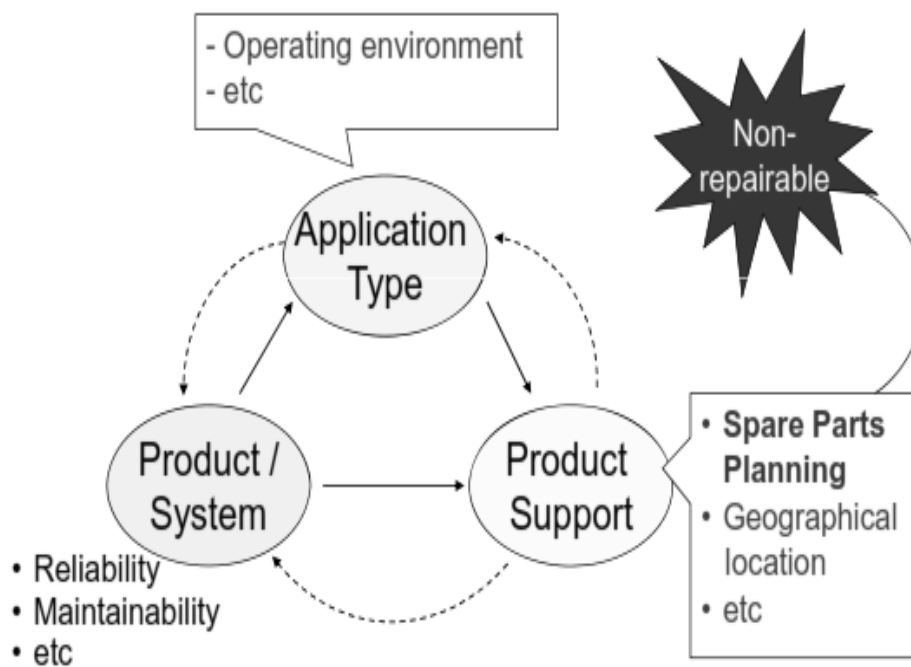

Figure 3.1: Spare part planning as part of product support (Markeset, 2011)

Until recently, the spare parts planning methods and optimization techniques for the most offshore facility has been focused on meeting the cost constrained and availability target. However, it is prudent to accept that the demand of spares and inventory management depends on issues like failure rate of the components/parts over a specified period of time and the consequence of their unavailability (Hassan et al., 2012). The procurement and holding policies used at the initial planning stage may not, therefore, guarantee through-life spare parts demand. Hence, in order to tackle such issues, the industry has been carried out numerous studies to investigate the forecasting techniques and other different challenges related to spare parts planning (Hassan et al., 2012).

Some of the studies by from various researches includes: different spares parts analysis methods and optimization techniques to determine the best approach that can meet the cost constrained and availability targets, considering the criticality of components as an important issue and uses criticality of spare parts to determine the initial adequate quantity of spares to be stored for executing maintenance effectively, proposing a risk-based methodology aiming to maximize the availability of a machine by maintaining a certain level of spare parts in the inventory (Adams, 2004, Dekker et al., 1998, Yang and Du, 2004, Bharadwaj et al., 2008, Hassan et al., 2012)

The objective of effective spare part planning, as being part of inventory control are: to relate spare part stock and store quantities to demand; to avoid losses due to spoilage, pilferage and obsolescence; to obtain the best turnover rate on all spare part items by considering both the cost of acquisitions and possessions; to reduce extended downtime due to un-deliverability of the spare part (Markeset, 2011). In order to achieve a cost-effective management of spare parts, the product support logistics play a crucial role in the process, with the aim to minimize the product costs, including cost of ordering, holding, transporting, production downtime etc. (Ghodrati, 2005). Furthermore, for O & G industries in the Arctic region spare part planning has a key role to play in reducing the consequences of the critical failures regarding to health, safety and/or environmental impacts. In addition, adequate spare part transportation management plan can help the user to investigate the appropriate path for transportation of the spare part and to estimate the probability of having the requested spare part on-site, within the planned delivery time.

However, the Arctic is characterized by extreme cold, varying forms and amounts of sea ice, seasonal darkness, high winds, polar lows, and extended periods of heavy fog, all of which can affect the spare part planning (Gudmestad et al., 2007, Barabadi et al., 2009, Gudmestad and Strass, 1994, Kayrbekova et al., 2011, Gao et al., 2010, Hasle et al., 2009). Hence, a spare part planning intending to meet company/market requirements, must take into consideration the effect of the operational conditions of the Arctic related to the transportation of the spare part and spare part demand forecasting.

Another important step in the spare part planning is the spare part evaluation. Longmore (2010) defines spare part evaluation as ‘spare parts evaluation is an exercise that is frequently started and rarely completed.’ This is due to the large number of spare parts typically involved, each with their own myriad of logistical complexities (Longmore, 2010). Figure 3.2 shows an overview of the workflow for evaluation of spare parts.

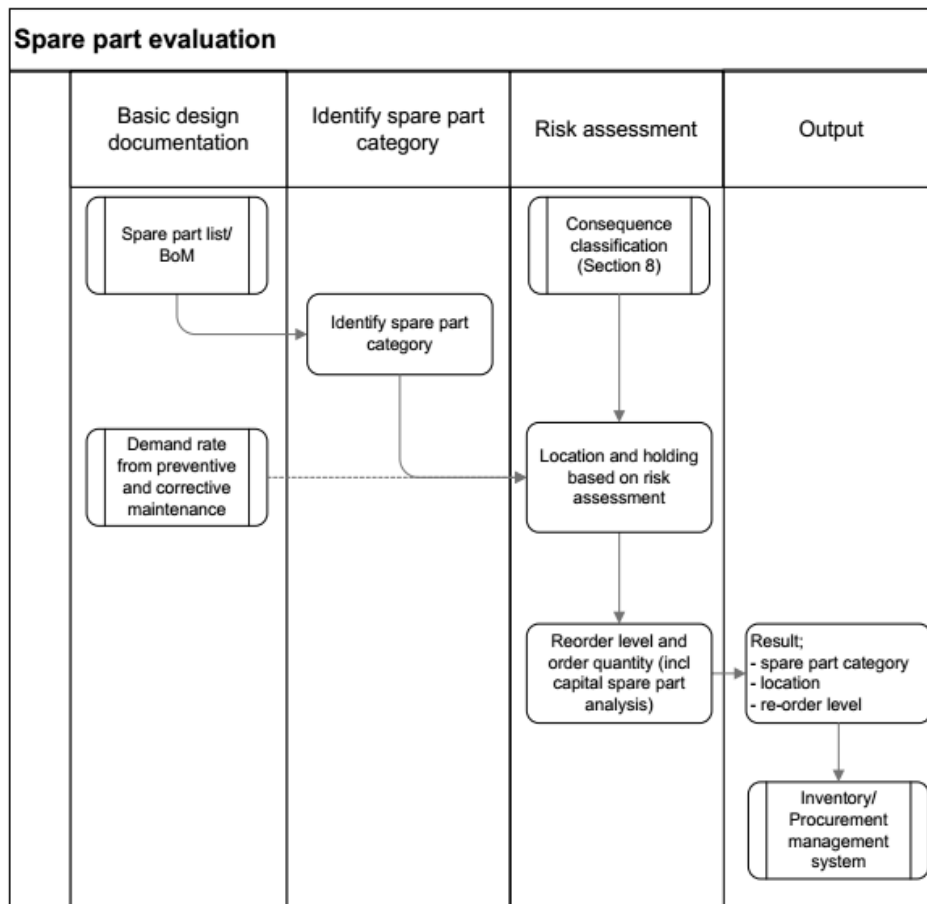

Figure 3.2: Evaluation of spare parts (NORSOK(Z-008), 2011)

Defining the storage location and holding of spare part based on risk assessment is the main part of the spare part evaluation. The first step that help user to define the storage location is to classify the spare parts based on their criticality. Criticality analysis is a quantitative analysis of events and faults and the ranking of these in order of the seriousness of their consequences (BS3811, 1984). Table 3.1 summarizes the criticality classification for spare parts based on the NORSOK Z-008 standard. However, the company goal defines the criticality classification of spare parts.

Table 3.1: Criticality matrix for spare parts (NORSOK(Z-008), 2011)

Criticality	Description
High	Equipment of a system that must operate in order to maintain operational capability in terms of health, safety, environment and production.
Medium	Equipment of a system that have redundancy installed, of which either the system or its installed spare parts must operate in order to maintain operational capability in terms of health, safety, environment and production.
Low	No consequence on health, safety, environment and production.

After criticality analysis, quantitative risk analysis can be used to determine the storage location. Risk is a combination of the probability, (or frequency) of occurrence of a defined hazard and the magnitude of the consequences of the occurrence (BS3811, 1984). In general, Table 3.2 summarizes the risk matrix for spare part storage location, and NORSOK Z-008 defines these main types of spare parts as follows:

- *Capital/insurance spare parts* are usually very expensive and have a very long lead time from the supplier. They are unlikely to suffer a fault during the lifetime of the equipment, and are vital to the function of the plant. The decision of the capital spares availability and location should be done through risk assessment.
- *Operational spare parts* are spare's during the normal operational lifetime, required to maintain the operational and safety capability. In the decision process for the location and holding of the operational spares, the criticality, redundancy and delivery time are important to consider. A recommendation is to evaluate these spares based on their criticality.

- *Consumable spare parts* are non-repairable with a high demand rate, for example bolts, nuts, screws etc., and are not item specific.

Table 3.2: Risk matrix for spare parts storage location
(NORSOK(Z-008), 2011)

Criticality	Consumable spare parts	Operational spare parts		Capital spare parts
	High demand (Short lead time)	Medium demand (Medium lead time)	Medium demand (Long lead time)	Low demand (Long lead time)
High	Adequate stock on site	Minimum stock on site & any additional spare parts at central warehouse	Minimum stock on site & any additional spare parts at central warehouse	Holding optimized by the use of risk assessment case by case
Medium	Minimum stock on site and any additional spare parts at central warehouse	Central warehouse , no stock on site	Central warehouse, no stock on site	No stock
Low	Minimum stock on site	No stock	No stock	No stock

In order to establish effective spare part planning, the reliability performance of the system and the failure rate of the item must first be estimated and /or predicted (Kumar et al., 2000b, Barabadi, 2012). Thus, Section 3.3 covers the overview of the basic concepts about the reliability performance of the system.

3.3. Reliability Performance

Reliability can be defined as the probability that an item can perform a required function under given conditions for a given time interval (CENELEC, 1999). Among the factors which have an important influence on the equipment reliability are *i*) period of use and *ii*) environment of use (Patra, 2007). Typical reliability parameters that have been used for production systems are: Mean Time To Failure (*MTTF*) – for non-repairable system and Mean Time Between Failure (*MTBF*) – for repairable system. A successful reliability engineering program has a high positive impact on life cycle cost (LCC). Figure 3.3 shows the effect of effective reliability program.

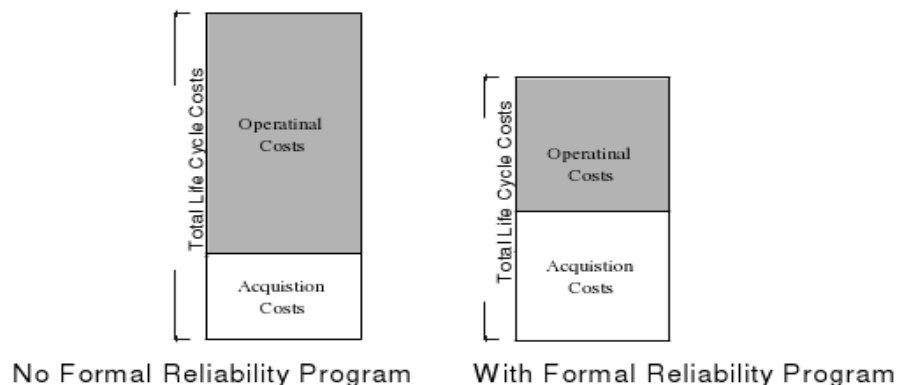

Figure 3.3: Impact of a reliability program on life cycle cost (LCC)
(Dhudsia, 1992)

In order to include the effects of operational conditions of the Arctic region while estimating reliability performance of the equipment, we need a model that considers the influencing factors. Proportional hazard model (PHM) can be used to estimate the risk of equipment failure, by calculating the effect of influencing factors in the equipment and the prediction of the equipment failure behavior (Kumar and Klefsjö, 1994).

Interest in applications of the PHM in reliability engineering has increased starting from early 90's, because of the potential for processing the reliability data without making any specific assumptions about the functional form of the hazard rate (Kumar and Klefsjö, 1994).

According to PHM, hazard rate of an item is the product of a baseline hazard rate, $h_0(t)$ that depends on time only, and a positive function which describes how the hazard rate changes as a function of covariate's as (Barabadi, 2012):

$$h(t, z) = h_0(t) \exp\left(\sum_{i=1}^n \beta_i z_i\right) \quad (3.1)$$

where z_i , $i=1,2,\dots,n$, are the covariate's associated with the item and β_i , $i=1,2,\dots,n$, are the regression parameters of the model which defines the effects of each one of the covariate's. An estimate of the β_i parameters can be obtained by maximization of the partial likelihood function (Kumar and Klefsjö, 1994). The baseline hazard rate represents the hazard rate which an item will experience when all covariate's are equal to zero (Barabadi, 2012).

The reliability function for the most widely used exponential form as follows (Gao et al., 2010):

$$R(t, z) = R_0(t) \exp\left(-\sum_{i=1}^n z_i \alpha_i\right) \quad (3.2)$$

where

$$R_0(t) = \exp\left[-\int_0^t \lambda_0(x) dx\right] = \exp[-H_0(t)t] \quad (3.3)$$

$R_0(t)$ is the baseline reliability function depends only on time and $H_0(t)$ the cumulative baseline hazard rate. Note that α_i and β_i are interchangeable.

3.4. Maintainability Performance

Maintainability is a design related function and must be engineered during the initial design, definition, and development phases of the life cycle (Patra, 2007). Maintainability can also be defined as “the probability that a given active maintenance action, for an item under given conditions of use can be carried out within a stated time interval, when the maintenance is performed under stated conditions and using stated procedures and resources” (IEV(191-02-03), 1990).

Maintainability is performed for the following reasons (Patra, 2007):

- To achieve ease of maintenance through design, reducing maintenance time and cost
- To estimate maintenance and system downtime
- To estimate labor, hours, time, and other resources for proper maintenance

Maintainability is most commonly measured by Mean Time To Repair (*MTTR*) and Mean Time Between Maintenance (*MTBM*). Figure 3.4 shows different time (s) involved in maintainability performance analysis.

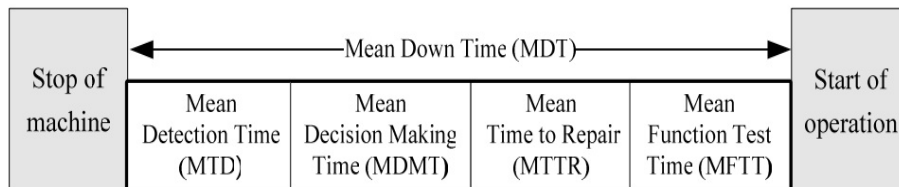

Figure 3.4: Mean Down Time (Barabady, 2005)

3.5. Maintenance Support Performance

Maintenance support performance is defined as: “the ability of a maintenance organization, under given conditions, to provide upon demand the resources required to maintain an item, under a given maintenance policy” (IEV(191-02-03), 1990). The performance of the maintenance organization may be assessed using organizational performance measurement systems, although delivery performance of external support services should be measured using performance measurement systems focusing on service delivery (Kumar and Markeset, 2007).

3.6. Spare Part Demand Forecasting

Relating stock and store quantities to demand is one of the main objectives of effective spare part inventory control. In order to estimate the required spare part demand, firstly classification of the spare part is necessary. In this thesis, the classification of the non-repairable spare parts are based on their criticality.

After classification and deciding which spare parts to be stocked and procured, the demand of the spare part can be forecasted. Demand forecasting is the one of the most challenging tasks in the spare part planning, and it involves uncertainties from a wide range of sources. The characteristics of spare parts demand and the criticality of an item are major issues that determine the technique of forecasting (Hassan et al., 2012, Ghodrati et al., 2007). The spare parts demand patterns can categorize into four categories: intermittent, erratic, slow moving, and lumpy demand (Ghobbar and Friend, 2002).

There are numerous studies and literature reviews about spare part demand forecasting techniques. The most common methods are: the single exponential smoothing model, Croston's method, Syntetos–Boylan approximation, moving average, weighted moving average, additive winter, multiplicative winter method, Poisson method, Binomial method, Grey prediction model, Box–Jenkins methods, and Neural network, renewal process, and Bayesian process (Amin-Naseri and Tabar, 2008, Syntetos and Boylan, 2005, Croston, 1972, Yar and Chatfield, 1990). Most of the papers describe the deterministic and probabilistic approaches to forecast the demand. Below, the most common demand forecasting models are briefly discussed.

3.6.1. Renewal Process Model

Let $N(t)$ denote the number of renewals (the number of demands, in context of this thesis) that occur by time t . Assuming that the time between renewal random variables $X_i; i \geq 1$, is independent and have common distribution $F(t)$, then the probability distribution of number of renewals is given by (Ghodrati and Kumar, 2005):

$$P(N(t) = n) = F^n(t) - F^{n+1}(t) \quad (3.4)$$

where $F^n(t)$ is the n -fold convolution of $F(t)$ and given by (Ghodrati and Kumar, 2005):

$$F^n(t) = \int_0^t F^{n-1}(t-x) dF(x) \quad (3.5)$$

$F^n(t)$ denotes the probability that the n^{th} renewal occurs by time t .

The expected number of renewals, $M(t)$, during a length of t is given by (Ghodrati and Kumar, 2005):

$$M(t) = \sum_{n=1}^{\infty} F^n(t) \quad (3.6)$$

The equation (4.4) is known as the Renewal Function. The renewal rate function $m(t) = dM(t)/d(t)$ gives the expected number of renewals per unit time.

By considering replacements of a part having an average time to failure as \bar{T} and the standard deviation of time to failures as $\sigma(T)$ (coefficient of variation of time to failures, $V = \sigma(T)/\bar{T}$), then the average number of failures can be estimated (Ghodrati and Kumar, 2005). Thus, if the operation time t of the system or machine on which this part is installed is quite long and several replacements need to be made during this period, then the average number of failures $E(N(t)) = M(t)$ will stabilize to the asymptotic value of the renewal function as (Gnedenko et al., 1969):

$$\begin{aligned} N_t = M(T) = E(N(t)) &= t/T + (V^2 - 1)/2 \\ &= \text{Average number of failures in time } t \end{aligned} \quad (3.7)$$

The harsh environmental condition of the Arctic region has a direct impact on the system reliability. Thus, the environmental conditions in which the equipment is to be operated such as the temperature, humidity, dust, etc. are needed to be incorporated with failure rate function (Kumar and Kumar, 1992, Kumar et al., 1992). Hence, the actual hazard rate (failure rate) in the Proportional Hazard Model (PHM) (Cox, 1972) with respect to the exponential form of the time-independent function, which incorporates the effects of covariate's (operation environment factors), can be defined as follows (Barabadi, 2012):

$$h(t,z) = h_0(t) \exp(\sum_{i=1}^n \beta_i z_i) \quad (3.8)$$

where z_i , $i=1,2,\dots,n$, are the covariate's associated with the item and β_i , $i=1,2,\dots,n$, are the regression parameters of the model which defining the effects of each one of the covariate's. An estimate of the β_i parameters can be obtained by maximization of the partial likelihood function (Kumar and Klefsjö, 1994). The baseline hazard rate, $h_0(t)$, represents the hazard rate which an item will experience when all covariate's are equal to zero.

3.6.2. Poisson Process Model

For forecasting the quantity of spares to be purchased and stored with a desired confidence level, a Poisson distribution can be used (Hassan et al., 2012). This distribution requires a single parameter that is the mean failure rate and can uphold the randomness of spare demand. Considering the event are exponentially distributed & components fail according to a Poisson process, the probability of n or fewer failures during a time interval of $(0, t)$ can be estimated by the following equation (Hassan et al., 2012):

$$P(n \text{ or fewer failure}) = \sum_{i=0}^n \frac{(\lambda t)^i}{i!} \exp(-\lambda t) \quad (3.9)$$

where λ is a failure rate.

Hence, based on the desired level of confidence or service level, the quantity of spare parts requirement can be estimated assuming a constant failure rate (Hassan et al., 2012). In the Poisson process model, the forecasting is solely based on the prior failure information, before demand data has been generated (Hassan et al., 2012). Thus, the forecasted quantity is usually overestimated (assuming a constant failure rate) and uncertainty also is not taken into consideration (Hassan et al., 2012).

3.6.3. Bayesian Model

As the uncertainty increases, the variation in the estimated demand increases exponentially (Hassan et al., 2012). To minimize uncertainty, the Bayesian method is the most appropriate tool for forecasting and continuous demand updating (Hassan et al., 2012). The Bayesian approach in demand prediction is suitable for either case of unknown demand with constant or varying demand rate (Popović, 1987).

The Bayesian technique, with respect to spare parts management, combines prior information with actual observed data derived from subsequent events to predict the future demand of spare parts (Hassan et al., 2012). The uncertainty in failure rate, i.e. demand, is tackled by considering it as a prior probability distribution, which is updated routinely in the form of the posterior distribution (Hassan et al., 2012).

Considering the failure rate (λ) of components as unknown, a prior assumption is made that failure rates follow a Gamma distribution and, as the consequences of failure as a Poisson distribution, the posterior Gamma distribution can be developed (Hassan et al., 2012).

Capability of developing an extensive array of mean and variance's encouraged to employ Gamma distribution as a demand prediction conjugate (Hassan et al., 2012). The prior Gamma distribution has two parameters; these are α and β , and the posterior Gamma will be with revised parameters α_0 and β_0 with generated demand data (Hassan et al., 2012). These two parameters are positive and real quantities similar to the variable failure rate (λ) (Hassan et al., 2012). The conjugate Gamma-Poisson probability function for k number of demands for spare parts with n operating unit during operating period t is given by the following equation (Brown Jr and Rogers, 1973).

$$P(k | \alpha, \beta) = \int_0^{\infty} \left(\frac{(n\lambda t)^k e^{-n\lambda t}}{k!} \frac{\beta^\alpha \lambda^{\alpha-1} e^{-\lambda\beta}}{\Gamma(\alpha)} \right) d\lambda \quad (3.10)$$

3.7. Risk Assessment Methods

The employment of risk management practices during the spare part planning phase, for an offshore facility is one of the important and demanding task. The risk assessment process is central to the overall formal safety assessment and therefore should be linked to the hazard identification process and control measure selection process (NOPSEMA, 2011). The applied risk assessment methodology should be efficient (cost-effective) and of sufficient detail to enable the ranking of risks in order, and it should also include the Arctic challenges, for subsequent consideration of risk reduction (HSE, 2006).

The rigor of assessment should be proportionate to the complexity of the problem and the magnitude of risk. It is expected that assessment would progress through the following stages to provide an appropriate demonstration (HSE, 2006):

- *Qualitative (Q)*, in which frequency and severity are determined purely qualitatively,
- *Semi-quantitative (SQ)*, in which frequency and severity are approximately quantified within ranges, and

- *Quantified risk assessment (QRA)*, in which full quantification occurs. These approaches to risk assessment reflect a range of detail of the assessment from Q (lowest) to full QRA (highest).

The choice of approach must take into account the following dimensions (HSE, 2006):

- The level of estimated risk (and its proximity to the limits of tolerability).
- The complexity of the problem and/or difficulty in answering the question of whether more needs to be done to reduce the risk.

In the risk dimension, the level of risk assessment used should be proportionate to the magnitude of risk, as shown in Figure 3.5 below. However, this may be modified according to the complexity of the decision that risk assessment is being used to inform (HSE, 2006).



Figure 3.5: Proportionate risk assessment (HSE, 2006)

3.7.1. Overview of Risk Assessment Techniques

Risk assessment is very relevant in the O & G industries. Each and every O & G companies need to manage risks, in order to assure the different requirements. These requirements can be related to the company, HSE, and the government requirement.

O & G industries have gained different advantages, by adopting a structured approach to risk assessment. There are different techniques that can be used to assess the risks. Assessing the risk can help to avoid or to reduce the negative impact of the risks on the industry. Below, some of the common risk assessment techniques are reviewed (ABS, 2003):

- *Hazard Identification Technique:* HAZID is a general term used to describe an exercise whose goal is to identify hazards and associated events that have the potential to result in a significant consequence.
- *Failure Modes and Effects Analysis:* FMEA is an inductive reasoning approach, and is a bottom-up, method which may be performed at either the functional or piece-part level. The FMEA technique (1) considers how the failure mode of each system component can result in system performance problems and (2) ensures that appropriate safeguards against such problems are in place.
- *Failure Modes, Effects, and Criticality Analysis:* FMECA is an extension of failure mode and effects analysis (FMEA). It includes a criticality analysis, which is used to chart the probability of failure modes against the severity of their consequences.
- *Hazard and Operability (HAZOP) Analysis:* the HAZOP analysis technique uses special guidewords to prompt an experienced group of individuals to identify potential hazards or operability concerns relating to pieces of equipment or systems. Guidewords describing potential deviations from design intent are created by applying a predefined set of adjectives (i.e. high, low, no, etc.) to a pre-defined set of process parameters (flow, pressure, composition, etc.)
- *Change Analysis:* change analysis looks systematically for possible risk impacts and appropriate risk management strategies in situations where change is occurring. This includes situations in which system configurations are altered, operating policies or practices are changed, new or different activities will be performed, etc.
- *What-if Analysis:* what-if analysis is a brainstorming approach that uses broad, loosely structured questioning to (1) postulate potential upsets that may result in mishaps or system performance problems and (2) ensure that appropriate safeguards against those problems are in place.

-
- *Checklist Analysis:* checklist analysis is a systematic evaluation against pre-established criteria in the form of one or more checklists.
 - *Event Tree Analysis:* ETA utilizes decision trees to graphically model the possible outcomes of an initiating event capable of producing an end event of interest. This type of analysis can provide (1) qualitative descriptions of potential problems (combinations of events producing various types of problems from initiating events) and (2) quantitative estimates of event frequencies or likelihoods, which assist in demonstrating the relative importance of various failure sequences.
 - *Fault Tree Analysis:* FTA is a deductive analysis that graphically models (using Boolean logic) how logical relationships among equipment failures, human errors and external events can combine to cause specific mishaps of interest. Similar to event tree analysis, this type of analysis can provide (1) qualitative descriptions of potential problems (combinations of events causing specific problems of interest) and (2) quantitative estimates of failure frequencies/likelihoods and the relative importance of various failure sequences/contributing events.

4. Results and Discussion

This chapter discusses and presents the results of the research study (thesis). The areas of discussions focus on the stated research objectives.

4.1. Factors affecting the spare parts planning and sources of uncertainties in the Arctic region

Beyond the usual factors, challenges, conditions and situations met by O & G industries, located in the NCS, the O & G industries in the Arctic region have a magnified challenges, risks and complications related to spare parts planning, especially for spare part transportation. Hence, the first objective of this research study is to review and discuss the main factors that can affect spare part planning and sources of uncertainty in the spare part planning under the Arctic conditions. In this section factors that influence spare part planning, especially spare part transportation are briefly reviewed. In addition, types and sources of uncertainties related to spare part planning are discussed.

4.1.1. Factors Affecting Spare Part Planning in the Arctic region

There are different factors which can influence spare part planning, especially the spare part transportation. Furthermore, the demanding operational condition of the Arctic region could exaggerate those influencing factors. In this section factors which can influence spare part transportation are briefly summarized.

4.1.1.1. Environmental Factors

Environmental factors are one of the most commonly known influencing factors that could have a direct impact on the spare part transportation in the Arctic region. For example, the complicated operational conditions due to ice, snow, and darkness for a long period of time in the high north region could cause unforeseen challenges for air-cargo transportation, which leads to delay and /or cancellation of flight, and cause a setback for spare part transportation. In addition, the cargo-ships operated in high north could face with the following challenges: variety of icy conditions, resistance in ice vs. open water, polar storms, longer distance, and extreme loads & responses. This challenge could lead to longer time of delivery of the spare parts, incur extra cost and extend the maintenance process. Furthermore, the low temperatures causes reduced cognitive and reasoning abilities and cognitive errors are more likely to occur. This causes a significant reduction of the effectiveness of the truck-cargo drivers, and possibility of mistakes or being inaccurate increases. The consequence of reduced operational effectiveness of the driver might be a significant error and damages to personnel and spare parts in hand. Thus, for effective spare part planning, the harsh and vulnerable environment of the Arctic region must be taken into consideration while we predict spare part transportation time.

4.1.1.2. Geographical Location Factor

The high O & G activity on the Norwegian Continental Shelf (NCS), has created a situation where many of the manufacturers and industrial service provider are located in the southwestern part of Norway (Markeset, 2008b); and this becomes a significant bottleneck for support and logistic operation in the Arctic region. The long distance between user and market together with the poor infrastructure and harsh weather conditions in the high north, creates several challenges for the supportability and for the 'worst case' lead to unacceptable downtime of the production process (Barabadi and Markeset, 2011). In other words, the location of the consignor and consignee influences the choice of mode(s) of transportation, which is one of the main factors in spare part planning; and this must be considered during the spare part planning and execution process.

4.1.1.3. Cost Factors

Spare part planning in O & G industries is a very complex process and every single, wrong decision can cost you a significant amount of capital (this might be money-wise, HSE cost, etc.). The best way of looking at costs related to spare parts is to examine them in conjunction with costs of the consequences of not having them in time of need (upon demand). This allows every O & G company to have a plan based on the risks of stock-outs and un-deliverability of the spare parts. The overall cost related to spare parts can be classified as cost of ordering, replenishing, and transporting. In addition, their cost of stock-outs and un-deliverability can also be classified as downtime cost, idle manpower cost, environmental impact cost, cost of remedy, and etc. Furthermore, these costs expected to exaggerate when we operate in the Arctic region. Hence, considering the cost factors while planning spare part must be the top priority.

4.1.1.4. Urgency Level Factor

The logistics service for spare parts follows different urgency levels according to O & G industries requirements, and based on the consequence of the stock-outs and un-deliverability of the spare part (within planned time). Consequence classification expresses what effect loss of function can have on HSE, production and cost/other (OLF, 2011). This is because of different urgency level requires a different range of spare part planning and execution skills (to tackle arctic challenges). Table 4.1 shows consequence matrix, and according to NORSOK Z-008 standard the consequence can be classified as high, medium, and low.

Table 4.1: Consequence matrix (NORSOK(Z-008), 2011)

Consequence	Health, safety and environment (HSE)	Production	Cost
3 - High	<ul style="list-style-type: none"> : Potential for serious personnel injuries : Render safety systems inoperable : Potential for fire in classified areas 	Stop in production/ significantly reduced rate of production exceeding X hours (specify duration) within a defined period of time	Substantial cost exceeding Y NOK. (Specify a cost limit)
2 - Medium	<ul style="list-style-type: none"> : Potential for injuries requiring medical treatment : Limited effect on safety systems : No potential for fire in classified areas 	Brief stop in production / reduced rate of production lasting less than X hours (Specify duration) within a defined period of time	Moderate cost between Z - Y NOK. (Specify a cost limit)
1 - Low	No potential for injuries, fire or affect safety systems	No effect on production within a defined period of time	Insignificant cost less than Z NOK. (Specify a cost limit)

4.1.1.5. Other Important Factors

In addition to the above factors, there are additional important factors that could affect the spare parts planning. These factors are: conditions of usage of spare parts (large population vs. small population), growth of the population of the main spare parts (since that affects the population in use during each year), swapping rate of spare parts (increasing failure rate causing changes in the replacement rates over the planning horizon), and interdependence of probability of failure among components (in several phases of product life cycle) (Krishnaswamy, 2004).

4.1.2. Types and sources of uncertainties in the Arctic region

Uncertainty can be defined as the lack of certainty, a state of having limited knowledge where it is impossible to exactly describe the existing state, a future outcome, or more than one possible outcome (Hubbard, 2010). Frank Knight (1921), in his famous book, 'Risk, uncertainty and profit', states that "*You cannot be certain about uncertainty*". In this section the types and sources of uncertainty, related to the spare part planning is briefly discussed.

The effect of the cumulative uncertainty on spare part planning may have two different aspects, namely *i*) the effect on the estimation of spare part transportation time, and *ii*) the effect on spare part demand forecasting. In general, there are around eight types of uncertainty: technological uncertainty, market uncertainty, regulatory uncertainty, social and political uncertainty, acceptance and legitimacy uncertainty, managerial uncertainty, timing uncertainty, and the consequence uncertainty (Jalonen and Lehtonen, 2011).

The uncertainty related to the spare part planning, can be divided into three categories: model, parameter, and unforeseen uncertainty. Model uncertainty refers to the statistical approach and its assumption which is used to build the model to analyze the spare part forecasting (Barabadi et al., 2011b), and also to estimate spare part transportation time. Model uncertainty occurs because the models and their assumptions are not perfect or always valid (Barabadi et al., 2011b). Parameter uncertainties result from the inability to quantify accurately the model inputs and parameters (Barabadi et al., 2011b). Unforeseen uncertainty is not formally identified in the spare part planning stage, that is, it is not anticipated, and a “Plan B” has not been formulated (De Meyer et al., 2002). While foreseen uncertainty is a major influence that can be anticipated (although we can only estimate a probability of its occurrence), there are at times influences that cannot or are not foreseen (De Meyer et al., 2002). In the case of unforeseen uncertainties, the spare part planning manager does not have a predefined response to the event, either because the manager is not aware of the possibility of the event, or that the event has such a low probability of occurrence that it is not worth creating contingencies in the original project plan (De Meyer et al., 2002).

The sources of uncertainties related to the Arctic region can be categorized in three main groups: *i*) harshness of the environment; *ii*) poor infrastructures; *iii*) lack of reliable data. In addition, lack of experience and expertise in regard to spare parts planning, in the Arctic region, might also be a source of uncertainty. Furthermore, unforeseen challenges due to the operational condition of the arctic region could cause unforeseen uncertainties related to spare parts planning. In addition, spare part planning and execution process is dependent on the reliability of the system (system reliability performance data).

Thus, prediction of system reliability in the Arctic region based on the available data (such as OREDA data), can be potential sources of uncertainties related to spare parts demand forecasting. In other word, in reliability analysis the historical data and covariate's are major sources of uncertainty. Covariate is any factor which can have an influence on the reliability performance of the item, and they can be the operational environment, geographical location, design material, maintenance history, operator and maintenance crew skill, etc. (Xie et al., 2005, Kumar and Klefsjö, 1994). Hence, these sources of uncertainties have non-negligible effects on spare part planning. Barabadi et al. (2011) summarizes the potential sources of uncertainties in system reliability assessment:

- A limited field data and information about covariate's and failure data in the Arctic region and the reference area (non-representative of historical data).
- Random error in measuring the time to failure (*TTF*) or time between failures (*TBF*) in the reference area (measurement errors).
- Inconsistency and non-homogeneity of *TBF* or *TTF* data in the reference area.
- Systematic bias due to mis-calibration of device in reference area or target area.
- Mis-classification or handling and transcription error in the field data in the reference and target areas.
- Lack of human failure data during operation and maintenance process in the reference area.
- Extrapolation of the result from the reference area to the target area (estimating the uncertainty for unobserved systems in the Arctic region)

In general, we can summarize the sources of the uncertainties into four major groups: Group I includes human (personal) factors, Group II contains client/owner/government factors, Group III comprises environmental and/or operational factors, and Group IV consists undesirable inputs. Figure 4.1 summarizes the cause and effect relationship of the main sources of uncertainties.

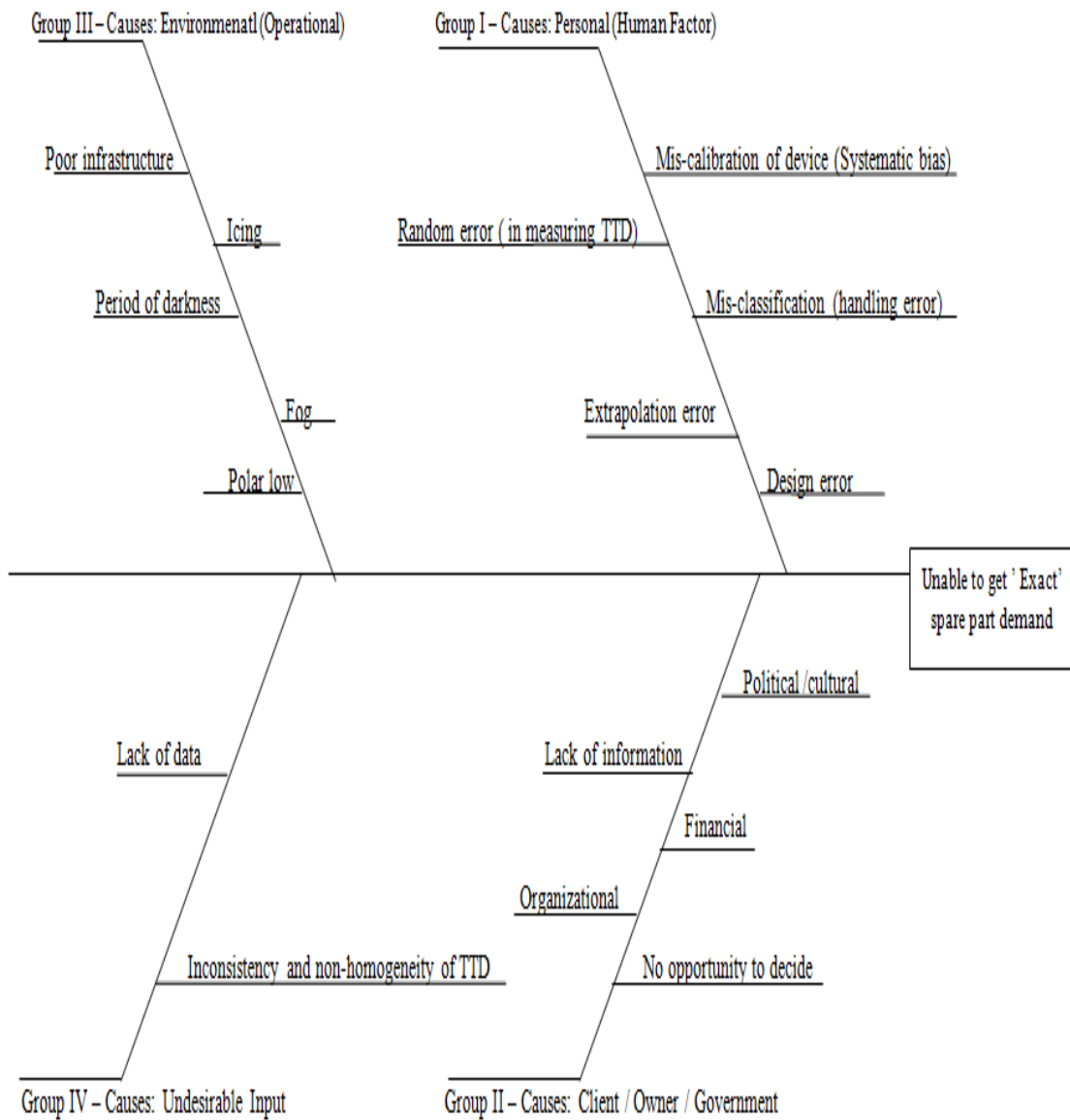

Figure 4.1: Cause and effect diagram for sources of uncertainties

In order to meet the spare part demand target and to reduce extended downtime due to stock-out and un-deliverability, effective handling of the uncertainties from various sources is unquestionably important. Different methods have been developed in order to describe the uncertainty related to the data collection such as reliability boundary, confidence intervals and probability distribution based on the Monte Carlo simulation (Moss, 1991, Yin et al., 2001, Sonnemann et al., 2003, Barabadi et al., 2011b).

Furthermore, modifying/developing approaches for uncertainty analysis, by considering the effect of operational conditions of the Arctic region, can help user to include the effects of uncertainties, during spare part planning – especially when estimating transportation time and demand forecasting.

4.2. The risk analysis and reduction measure for the spare part planning

The second objective of this research study (thesis) is to review and analyze the risk assessment and reduction measures for the spare part planning by taking into consideration the effect of the operational conditions in the Arctic region. As O & G industries attempt to maximize the value of each project and optimize their portfolio of spare part investment, it is vital that all risks are properly identified and quantified. This helps to maximize value and increase the effectiveness of the spare parts planning. NORSOK Z-008 (2011) standard recommends quantitative risk assessment, for estimation of the risk and criticality of unavailability of the spare part. Quantitative risk analysis attempts to estimate the frequency of accidents and the magnitude of their consequences by different methods, such as the fault tree and the event tree methods (Ghodrati et al., 2007). The key purpose of risk assessment is to support management in rational decision making (Hassan et al., 2012). The risk in this thesis context is the risk in monetary terms that arises due to stock-outs and un-deliverability of the spare part within the planned delivery time. Figure 4.2 shows both quantitative and qualitative risk analysis methods.

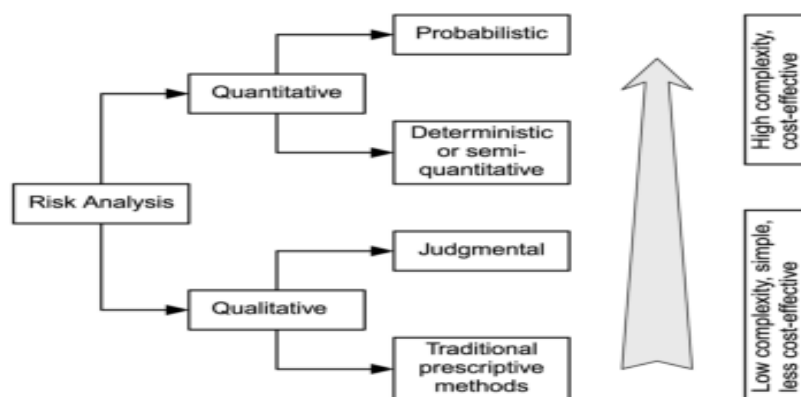

Figure 4.2: Risk analysis options (Rasche and Wooley, 2000)

In order to ensure the availability of the critical spare parts upon demand and to evaluate the risk associated with un-deliverability and stock-outs, effective risk assessment needs to be performed. Furthermore, risk analysis helps the user to evaluate the risk associated with longer lead time which is much anticipated when we operate in the Arctic region. In spare part planning it is very important to predict the risk due to un-deliverability of the spare part within intended planned time. It facilitates to avoid extended down-time caused by the un-deliverability of the spare parts and reduce the loss of production. Furthermore, it helps to ensure that the right spare part and resources are in the right place at the right time, in the hands of the right person. Hence, it is essential to have a probabilistic estimation of the un-deliverability of the spare part, during the initial stage of spare part planning. The risk level due to un-deliverability of the spare part can be lowered by changing the procurement policy of spare parts (Hassan et al., 2012). A procurement policy is simply the rules and regulations that are set in place to govern the process of acquiring spare parts and services needed by an organization to function efficiently (Tatum and Harris, 2013). The minimum lead time procurement strategy can be suitable in order to reduce the risks due to un-deliverability of the spare part. In general, the risk associated with un-deliverability of the spare part can be expressed as:

$$\text{Risk } (R_U) = P_{un} \times C_{un} \quad (4.1)$$

where: Risk (R_U) is monetized cost, P_{un} is the probability of un-deliverability of the spare part within the planned delivery time, and C_{un} is the consequences un-deliverability, i.e. cost of not having the spare part within the planned delivery time.

Probabilities of un-deliverability of the spare part are primarily obtained from either logistic companies or judgment from experienced spare part planning managers. Time to delivery (transportation time) information is important in quantification of risks associated with the un-deliverability of the spare part. Historical transportation time data, or estimation of travel time can be used as a basis for determining suitable probabilities of un-deliverability of the spare part. Spare part un-deliverability consequences can be the financial losses due to the delay/cancellation. The financial loss consequences include several factors, such as cost of extended down-time (\$), cost of idle manpower (\$), and HSE cost (\$). The cost analysis and the time to delivery (TTD) data can assist in quantifying the risk (\$) associated with the specific delay and/or cancellation.

In addition to risks due to un-deliverability, there are also risks due to unavailability of the spare part upon demand. The cumulative unavailability of the machine (in the case of a spare parts shortage) and the added cost incurred can quickly affect the financial performance of a system (Ghodrati and Kumar, 2005). Due to economical issues and sporadic nature of component failures, it is impossible to always maintain the availability of the spare part upon demand. Hence, risk analysis related to stock-out of the spare part can help to reduce the consequences of the unavailability of the spare part. In general, the risk associated with stock-outs can be expressed as (Fortuin and Martin, 1999):

$$\text{RISK}_i = \text{Probability} (D_i > S_i) \times C_i \quad (4.2)$$

where: RISK_i is expected financial loss due to risk item i being out of stock, D_i is demand for an item i during its entire (or remaining) life cycle, S_i is the initial number of items of type i in stock, and C_i is financial consequences if an out-of-stock situation occurs for an item i .

In order to minimize the financial loss due to stock-outs, the probability that the demand could go beyond the expected level must have to be taken into consideration. The consequence of the inadequacy of spare parts includes the cost of procurement of spare parts and the cost of downtime of a unit due to the unavailability of spares (Hassan et al., 2012). The consequence of the stock-out can vary based on the criticality of the spares. In addition, the sporadic nature of the component failure must be analyzed, in order to have a better understanding of the consequence of the stock-out. This will provide an aid to the management to make a decision based on the risk the unavailability of the spares (Hassan et al., 2012).

In addition, successful risk management depends on a clearly defined scope for the risk assessment, comprehensive and detailed hazard mapping and a thorough understanding of the possible consequences (Ghodrati et al., 2007). Figure 4.3, shows risk management as an iterative process, and in context of the spare part planning, the system (in figure 4.3) can be described as the procurement policy.

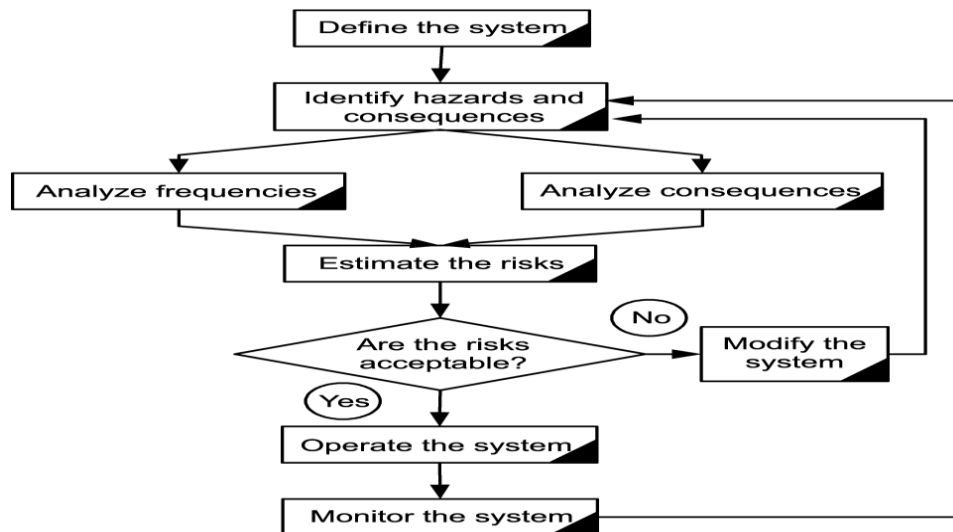

Figure 4.3: Risk management process (Ghodrati et al., 2007)

4.3. Spare part transportation management in the Arctic region

The third objective of this research study is to develop a spare part transportation and dynamic model, in order to predict spare part transportation time by considering the effect of the Arctic conditions. In Paper I, an approach for the estimation of mean spare part transportation time and prediction of the probability of having the spare part on-site is presented. Paper II presents and discusses the effects of dynamic behavior of the transportation network related to spare parts planning.

4.3.1. Spares part transportation block diagram

The long-distance location of manufacturers and providers of industrial services and skilled manpower, insufficient infrastructure together with the remote geographical location are some of the most important factors that must be considered during the spare part planning in the Arctic region. In order to facilitate the spare part planning and execution process, effective spare part transportation plan must be developed.

Hence, a spare part transportation management plan, intending to meet company/market requirements, by considering the effect of the operational conditions of the Arctic, is essential. In addition, the plan can also help the user for better prediction of travel time and probabilistic estimation of delivery time. In order to achieve this, in the paper I we develop the concept of spare part transportation block diagrams (STBD).

The aim of the model is to introduce the concept of the spare part transportation block diagram (STBD) for possible transportation routes and mode of transportation. The first step in the spare part modeling is defining mode of transportation such as air-cargo, ship-cargo, or truck-cargo. In addition, a collection of time to delivery data is carried out, and the size of the spare part is assumed that it is within a limit that can be transported by air-cargo, ship-cargo, and truck-cargo. Figure 4.4 shows combined spare part transportation network. In figure 4.4, P_i is the probability that one mode is chosen from the available alternatives, D_i is spare part deliverability, and $MTTD$ is mean time to delivery.

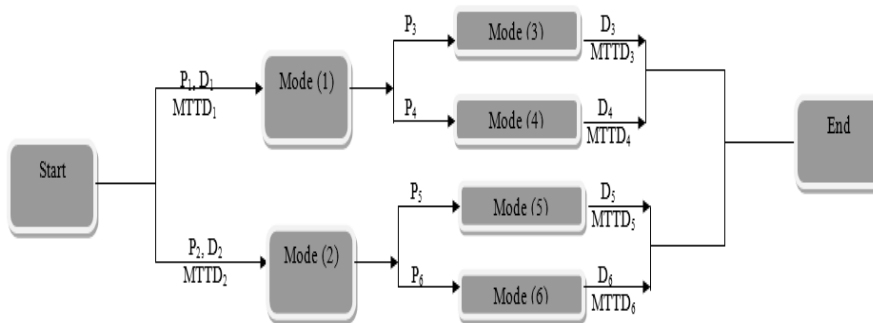

Figure 4.4: Combined spare part transportation network

Identifying possible transportation route is the second step in the modeling process. In the STBD model, the three main types of configuration are used, namely series, parallel and combined. It must be considered that when there is a combined/parallel configuration, different routes can be selected for transportation. However, these routes do not have the same weight in the decision making process. In order to show this concept, the probability of selecting one mode, P_i from the available mode's needs to be defined, where $0 \leq P_i \leq 1$ and $\sum P_i = 1$.

Selecting a common probability distribution, and then quantification of the spare part deliverability of each mode, is the third step. Spare part deliverability in a given network and specific mode of transportation, is a probability that the spare part will be delivered, under a given condition, within an intended planned delivery time. The STBD is used to measure how probable it is to have the spare part on-site, within the planned delivery time. The time to deliverability of the network is determined by - calculating the deliverability of blocks and considering the relationship between the different blocks. In the common probability distributions the only variable is the time to delivery (TTD), however, the covariate model can be used to model the effect of operational conditions the Arctic region on the spare part deliverability. In the paper I, the model is based on the common probability distributions.

The STBD for our model, is time-dependent because of uncertainty regarding the travel time. Time-dependent analysis looks at the deliverability of spare parts as a function of time to delivery (*TTD*) and operational conditions. The final step is spare part deliverability analysis for the network. Then, calculation the spare part deliverability for each mode is carried out. In order to calculate the deliverability of the network or STBD, the relationship between each mode is modeled.

The application of the proposed model is demonstrated by a case study from the O & G industry (Paper I). The users can make use of the model, to estimate the mean time to delivery of spare parts, and also to estimate the probability of having the requested spare part on-site within the planned time, considering the operational conditions. In the case study, comparing the network deliverability of the summer and winter seasons shows that there are approximately 20% extended delay's during the winter season due to the operational conditions. Hence, any decision about the transportation of spare parts in the Arctic region must consider the effects of the operational conditions of the region.

4.3.2. Dynamic spare parts transportation model

The complex operational condition of the Arctic region provides dynamic behavior and has an effect on the transportation network dynamics. These issues could affect the estimation of time to delivery of the spare part and the probability of having the spare part within intended time. Furthermore, for O & G industries, it is of a high importance that the required spare parts are on-site upon demand and/or cargo containing critical spare parts reaches on-site as fast as possible. Hence, ignoring the effect of the dynamic behavior of the transportation network and using the conventional methods may increase the uncertainty and lead to inaccurate results. Therefore, spare parts transportation management plan, that consider the dynamic behavior of the transportation network and the operational conditions of the Arctic region is very crucial.

In order to predict spare part transportation time by considering the dynamic effect of the Arctic conditions, in paper II we develop a dynamic transportation model. The aim of this paper is to introduce the concept of the dynamic spare part transportation block diagram (DSTBD) for possible transportation routes and mode of transportation. The initial idea for the model comes from the dynamic reliability block diagram (DRBD), which is used in reliability engineering in order to calculate the reliability of the dynamic system (Distefano and Puliafito, 2009). In addition, the effect of the operational conditions of the Arctic region on transportation mode choices is modeled. Furthermore, the concept of dependency with respect to the dynamic relationship between transportation mode choices, criticality of the spare part, and season (months) of the year (i.e. to transport the spare part) is also modeled.

The first step in the model is to develop logistic function, in order to estimate the probabilities of the different mode choices based on the latent variables (such as criticality hierarchy, fog condition, snow condition,...). The logistic function/regression is used when the dependent variable in question is nominal (equivalently categorical, meaning that it falls into any one of a set of categories which cannot be ordered in any meaningful way) and for which there are more than two categories. For example, which mode of transport will be chosen, given that the required spare part has a medium high criticality, no fog condition, and some specific amount of transportation cost etc.?

In general the basic properties of the probability that mode i to be chosen from n alternatives is: $0 \leq P_i \leq 1$ and $\sum_{k=1}^K P_k = 1$, where K is the total number of alternatives (mode of transport). Using logistic regression, the probability that mode i to be chosen from n alternatives is determined and can be expressed as:

$$P_i = \frac{1}{1 + \exp[\sum_{i=0}^k \beta_i x_i + \sum_{j=0}^m \delta_j x_j(t)]} \quad (4.3)$$

where β_i and δ_j are regression coefficient indicating the relative effect of a particular explanatory variable on the outcome, x_i are explanatory variables for time independent covariates, and $x_j(t)$ are explanatory variables for time-dependent covariates, k is the number of time-independent covariates and m is the number of time-dependent covariates.

The DSTBD is used to consider the dynamicity of transport networks, and to measure how probable it is to have the spare part on-site (within the planned delivery time). The DSTBD, in our model is dynamic and time-dependent network, this is due to the dependency of the dynamic relationship between the probability that mode i to be chosen from n alternatives (P_i), the effect of time-dependent covariates, and the uncertainty regarding the travel time. Dynamic and time-dependent analysis looks at the spare parts dynamic deliverability as a function of time to delivery (TTD) and operational conditions (covariates).

In general, after the estimation of the probability of selection of each mode of transportation from available alternatives, the next step is to estimate the spare part deliverability. In paper II, we use spare part dynamic transportation block diagram (DSTBD), in order to estimate the spare part deliverability. By using the extension of PHM, the dynamic spare part deliverability can be expressed as:

$$D(t, z) = 1 - [(1 - D_0(t)) \exp[\sum_{i=1}^n \beta_i z_i + \sum_{j=1}^m \delta_j z_j(t)]] \quad (4.4)$$

where $D_0(t)$ is the spare part deliverability without considering the effect of influence factor, β_i and δ_j are column vectors consisting of the regression parameters, z_i is a time-independent covariate and $z_j(t)$, is a time-dependent covariate, n is the number of time-independent covariates and m is the number of time-dependent covariates.

In paper II, we try to model the dynamic spare part transportation block diagram, in order to assess the effect of the operational condition of the Arctic region on the spare part transportation. However, in order to generalize the results and findings to the theoretical propositions, the proposed models must be tested through replication of findings in more case studies.

4.4. Summary of appended papers

This research study includes two appended papers. The results and the conclusions of the appended papers are summarized in this chapter. The relationship between the papers and the research questions is illustrated in Table 4.2. Three + or (+++) is the highest ranking, while blank is the lowest.

Table 4.2: The relations between the papers, the main thesis and the research questions

Paper/Main Thesis	Research Question 1	Research Question 2	Research Question 3
Main Thesis	+++	+++	
Paper I	+		+++
Paper II	+		++

Paper I: The demanding physical conditions of the Arctic, the remote location, and the uncertainty regarding the travel time can increase the challenges related to the transportation of spare parts in the region. Thus, designing and implementing an appropriate path for the transportation of spare parts for the region's oil and gas industry is a major problem. Hence, in a Paper I, we develop the concept of spare part transportation block diagrams (STBD) for possible transportation routes. In this method, each transportation tool (e.g. truck, railway, etc.) is modeled by a block, and then a transportation route can be formed by a series of these blocks. Furthermore, the concept of the transportation network is used to calculate the mean time for transportation for each route. The application of the model is demonstrated by a case study of the transportation of spare parts for the Goliat Oil and Gas Field in the Barents Sea, Norway.

The results obtained from data analysis showed that the spare part transportation block diagrams (STBD) can be used as tools to analyze different means of transportation connected network-wise considering the operational conditions. STBD can help the user to investigate the appropriate path for the spare part transportation, from manufacturer to on-site or from operator/owner's warehouse to on-site. In addition, STBD is helpful in supporting the user to estimate the probability of having the requested spare part on-site, within the planned delivery time. In the case study, comparing the network deliverability of the summer and winter seasons shows that there are approximately 20% extended delay's during the winter season due to the operational conditions. Hence, any decision about the transportation of spare parts in the Arctic region must consider the effects of the operational conditions of the region.

Paper II: The Arctic region provides a dynamic operational condition with respect spare part planning, especially spare part transportation. Hence, a system which intends to create a productive spare part transportation management with an appropriate consideration of the dynamic behavior of the Arctic region is the suitable approach. In paper II we develop the concept of dynamic spare part transportation block diagram (DSTBD) for possible transportation modes and routes. Furthermore, the factors which provide dynamic behavior of a spare part transportation network such as season (months) of the year (i.e. to transport the spare part), and criticality of the spare part are modeled.

The results showed that the DSTBD can help the user to investigate the appropriate path for the spare part transportation, by considering the dynamic behavior of the transportation network which is caused by the operational condition of the Arctic region. In addition, DSTBD is helpful in supporting the user to estimate the dynamic probability of having the requested spare part on-site, by considering the influence factors (covariates). However, the proposed models must be tested through replication of findings in more case studies.

5. Research contribution

This research study (thesis) contributes to a better understanding of the spare part planning, especially spare part transportation in harsh, remote and sensitive Arctic conditions. In this research study, the main sources of uncertainty and risks related with spare part planning (spare part transportation), under the Arctic condition are reviewed.

A model is developed for static and dynamic spare part transportation considering the operational conditions. These models facilitate the spare part planning and execution process. The application of the static model is demonstrated using a case study.

The application of the extension of PHM is developed and extended for determining the dynamic spare part deliverability considering time-dependent covariates. However, the proposed models must be tested through replication of findings in more case studies.

The study presented in this thesis can assist engineers and managers, who design and make decisions on transportation network configuration, to estimate the spare part transportation time and predict both static and dynamic spare part deliverability. Furthermore, it can help them to find which factor of operational conditions has more effect on the spare part transportation time, and to estimate the associated risk with stock-out and un-deliverability of the spare part.

6. Suggestion for further research

Based on the research presented in this thesis and the two appended papers, the following points for future research are suggested:

- Uncertainty analysis related to transportation of spare part must be integrated with spare part planning.
- Improvement of the data collection related to transportation time in order to have a better understanding of the effect operational condition of the Arctic region on the spare part planning.
- Investigation of the correlation between the un-deliverability of the spare part and influence factors i.e. the covariate's.

7. References

Barabadi, A. 2011. Production Performance Analysis : *Reliability, Maintainability and Operational Conditions*. Doctor of Philosophy PhD, UiS.

Barabadi, A. 2012. Reliability and Spare Parts Provision Considering Operational Environment: A Case Study. *International Journal of Performability Engineering*, Vol 8, 497.

Barabadi, A., Barabady, J. & Markeset, T. 2009. Management of Production Assurance in Harsh, Remote, and Sensitive Environment. *The Proceedings of the 20th International Conference on Port and Ocean Engineering under Arctic Conditions (POAC2009)*.

Barabadi, A., Ghodrati, B., Barabady, J. & Markeset, T. 2012. Reliability and Spare Parts Estimation Taking into Consideration the Operational Environment - A Case Study. *IEEE Press*.

Blaikie, N. 2009. Designing Social Research, Polity.

Burton, G. C. & Feijo, L. P. 2008. Practical Role of Classification Societies in Verifying Safe Design on Offshore Oil and Gas Facilities.

Creswell, J. W. 2008. Research Design: Qualitative, Quantitative, and Mixed Methods Approaches, Sage Publications, Incorporated.

Creswell, J. W., Fetters, M. D. & Ivankova, N. V. 2004. Designing a Mixed Methods Study in Primary Care. *The Annals of Family Medicine*, Vol 2, 7-12.

Dependability and Quality of Service / Failures. IEC 191-04-01.

Dependability and Quality of Service / Failures. IEC 191-05-01.

Dependability and Quality of Service / Failures. IEC 191-05-24.

Dependability and Quality of Service / Failures. IEC 191-07-01.

Dependability and Quality of Service / Failures. IEC 191-12-07.

Dependability and Quality of Service / Failures. IEC 191-13-08.

Dependability and Quality of Service / Failures.

Dependability and Quality of Sservice / Failures. IEC 191-02-05.

Dependability and Quality of Service / Failures. IEC 191-02-06.

Gao, X., Barabady, J. & Markeset, T. 2010. An Approach for Prediction of Petroleum Production Facility Performance Considering Arctic Influence Factors. *Reliability Engineering & System Safety*, Vol 95, 837-846.

Gao, X., Markeset, T. & Kumar, U. 2007. A Review of Production Assurance in the Norwegian Petroleum Industry. *Proceedings of the Seventh International Conference on Reliability, Maintainability and Safety*.

Ghodrati, B. 2006. Weibull and Exponential Renewal Models in Spare Parts Estimation: A Comparison. *International Journal of Performability Engineering*, Vol 2, page 135.

Given, L. M. 2008. *The SAGE Encyclopedia of Qualitative Research Methods*, Sage Publications.

Gudmestad, O., Alhimenko, A., Løset, S., Shkhinek, K., Tørum, A. & Jensen, A. 2007. Engineering Aspects Related to Arctic Offshore Developments. *Student's Book for Institutes of Higher Education*, St. Petersburg Publisher.

Gudmestad, O. T. & Strass, P. 1994. Technological Challenges for Hydrocarbon Production in the Barents Sea. *Power Technology and Engineering (formerly Hydrotechnical Construction)*, Vol 28, 460-471.

-
- Hasle, J. R., Kjellen, U. & Haugerud, O. 2009. Decision on Oil and Gas Exploration in an Arctic Area: Case study from the Norwegian Barents Sea. *Safety Science*, Vol 47, 832-842.
- Hassan, J., Khan, F. & Hasan, M. 2012. A Risk-based Approach to Manage Non-repairable Spare Parts Inventory. *Journal of Quality in Maintenance Engineering*, Vol 18, 344-362.
- Kalbfleisch, J. D. & Ross, L. P. 2002. *The Statistical Analysis of Failure Time Data*. New York, NY: John Wiley & Sons Publisher.
- Kayrbekova, D., Barabadi, A. & Markeset, T. 2011. Maintenance Cost Evaluation of a System to be used in Arctic Conditions: A Case Study. *Journal of Quality in Maintenance Engineering*, Vol 17, 320-336.
- Kerlinger, F. N. & Lee, H. B. 1986. *Foundations of Behavioral Research*.
- Kumar, D. & Westberg, U. 1997. Some Reliability Models for Analyzing the Effect of Operating Conditions. *International Journal of Reliability, Quality and Safety Engineering*, Vol 4, 133-148.
- Kumar, U., Crocker, J., Knezevic, J. & El-Haram, M. 2000. *Reliability, Maintenance and Logistic Support: A Life Cycle Approach*. New York: Kluwer Academic Publishers.
- Lyberg, L. & Kasprzyk, D. 1991. Data Collection Methods and Measurement Error: An Overview. *Measurement Errors in Surveys*, 235-257.
- Miller, M. J. 2012. Graduate Research Methods [Online]. Western International University. Available: http://michaeljmillerphd.com/res500_lecturenotes/Reliability_and_Validity.pdf.
- Neuman, W. L. 2003. The Meanings of Methodology. *Social Research Methods: Qualitative and Quantitative Approaches*, 68-94.
- Patra, A. P. 2007. *RAMS and LCC in Rail Track Maintenance*, Luleå University of Technology.

ReliaSoft. 2007. User's Guide Blocksim 7.

Sagepub. 2012. *Qualitative, Quantitative, and Mixed Methods* [Online]. Available: sagepub.com.

Shuttleworth, M. 2008. What is Research. Retrieved September, 6, 2012.

Soy, S. K. 1997. The Case Study as a Research Method. University of Texas at Austin.

Steffanusen, T. 2012. Spare Parts Management in the Barents Sea. Master Degree Thesis, University of Tromsø.

Straub, D., Gefen, D. & Boudreau, M. C. 2004. The is World Quantitative, Positivist Research Methods. *Electronic Source*.

Sullivan, T. J. 2001. Methods of Social Research, Harcourt College Publishers.

Sumser, J. 2000. A Guide to Empirical Research in Communication. Sage Publications.

Todinov, M. T. 2007. Risk-based Reliability Analysis and Generic Principles for Risk Reduction, Elsevier Science Limited.

Umar, A. A. 2010. Design for Safety Framework for Offshore Oil and Gas Platforms. University of Birmingham.

Utter, R. E. & Utter, B. 2005. Accelerated Life Test – Your Key to New Product Success.

Yin, R. K. 1984. The Case Study Research Method.

Yin, R. K. 2008. Case Study Research: Design and Methods, Sage Publications.

Part II – Appended Papers

Paper I

Ayele Y.Z. , Barabadi, A and Markeset, T (2013). Spare Part Transportation Management in the High North.

Submitted to International Conferences on Port and Ocean Engineering under Arctic Conditions (POAC2013).

Spare Part Transportation Management in the High North

Ayele, Y.Z.¹, Barabadi, A.¹ and Markeset, T.^{1,2}

¹ University of Tromsø, N-9037 Tromsø, NORWAY

^{1,2} University of Stavanger, N-4036 Stavanger, NORWAY

ABSTRACT

The demanding physical conditions of the Arctic, the remote location, and the uncertainty regarding the travel time can increase the challenges related to the transportation of spare parts in the region. Thus, designing and implementing an appropriate path for the transportation of spare parts for the region's oil and gas industry is a major problem. In this paper we develop the concept of spare part transportation block diagrams (STBD) for possible transportation routes. In this method, each transportation tool (e.g. truck, railway, etc.) is modeled by a block, and then a transportation route can be formed by a series of these blocks. Furthermore, the concept of the transportation network is used to calculate the mean time for transportation for each route. The application of the model is demonstrated by a case study of the transportation of spare parts for the Goliat Oil and Gas Field in the Barents Sea, Norway.

Keywords: Spare part, Transportation, Block diagram, Deliverability

1. INTRODUCTION

Currently, oil and gas exploration and production is moving to the High North, the Arctic region. This unfamiliar operational environment of the Arctic poses new challenges for the industry (Gudmestad et al., 2007, Barabadi et al., 2009, Gudmestad and Strass, 1994, Kayrbekova et al., 2011). Due to the severe and complex operational conditions in the Arctic, the consequences of a failure relating to human, safety and/or environment can be much higher than in other areas. Moreover, in an industry with a high level of investment, such as offshore oil and gas, the costs of the production losses due to failure and downtime are substantial, which can affect business performance (Gao et al., 2010).

Maintenance activity can act as a barrier to reduce the risk related to failures. Preventive maintenance, as an active barrier, can reduce the probability of failure, and corrective maintenance, being a passive barrier, can reduce the consequence of failures. Hence, it is very important to have an effective maintenance strategy from the early design stage and to keep it updated based on experience gained during the operation phase (Gao et al., 2010, Gao et al., 2007). Product support and spare part planning are important prerequisites for an effective maintenance program. They can have a significant economic impact, by helping to maintain the reliability of the system, by reducing the downtime, and by facilitating the maintenance process.

In spare part planning it is very important to predict the transportation time of the spare parts precisely (Barabadi, 2012, Barabadi et al., 2012). This helps to avoid down-time and stock-outs caused by the unavailability of spare parts. Moreover, it helps to ensure that the right spare part and resources are in the right place at the right time, in the hands of the right person. Hence, it is essential to develop a spare part transportation management plan for better prediction of travel time and probabilistic estimation of delivery time. In this case the quickest and most economical possible delivery of the requested spare parts must be ensured (Ghodrati, 2006).

In spare part planning it is very important to predict the transportation time of the spare parts precisely (Barabadi, 2012, Barabadi et al., 2012). This helps to avoid down-time and stock-outs caused by the unavailability of spare parts. Moreover, it helps to ensure that the right spare part and resources are in the right place at the right time, in the hands of the right person. Hence, it is essential to develop a spare part transportation management plan for better prediction of travel time and probabilistic estimation of delivery time. In this case the quickest and most economical possible delivery of the requested spare parts must be ensured (Ghodrati, 2006).

The Arctic is characterized by extreme cold, varying forms and amounts of sea ice, seasonal darkness, high winds, polar lows, and extended periods of heavy fog, all of which can affect the transportation time of spare parts (Gudmestad et al., 2007, Barabadi et al., 2009, Gudmestad and Strass, 1994, Kayrbekova et al., 2011, Gao et al., 2010, Hasle et al., 2009). Moreover, the long-distance location of manufacturers and providers of industrial services and skilled man-power, insufficient infrastructure together with the remote geographical location are some of the most important factors that must be considered during the spare part planning. Hence, a spare part transportation management plan, intending to meet company/market requirements, by considering the effect of the operational conditions of the Arctic, is essential.

The aim of this paper is to introduce the concept of the spare part transportation block diagram (STBD) for possible transportation routes and mode of transportation to facilitate the spare part planning and execution process. The model also helps users to estimate the mean time to delivery of spare parts, and also to estimate the probability of having the requested spare part on-site within the planned time, considering the operational conditions. The rest of the paper is organized as follows: Section 2 introduces the STBD concepts. Section 3 presents a description of the case study and the application of the STBD model. Section 4 provides the conclusion.

2. SPARE PART TRANSPORTATION MODEL, STBD

In order to establish effective transportation management, all possible transportation routes need to be identified and then, for each route, the time and cost of the transportation need to be calculated. To achieve this aim, the concept of spare part transportation block diagrams (STBD) is developed in this paper. The initial idea for the model comes from the reliability block diagram, which is used in reliability engineering in order to calculate the reliability of the system (Barabadi et al., 2009).

An STBD is a success-oriented network describing the functions of a transportation system. Specifically, each STBD model consists of an input point (starting point), an output point (ending point), and a set of blocks. Each block represents a transportation mode, like air-cargo, that functions correctly (Steffanusen, 2012). The block diagram shows how blocks (modes of transportation) are connected together and is used to facilitate understanding of the complete array of modes of transportation by breaking them down into the most dominant modes (air, land, and water) (Steffanusen, 2012). An STBD is easy to read and understand for the designer and manager, who design and make decisions on system configuration.

An STBD is used to measure how probable it is to have the spare part on-site, within the planned delivery time. The time to deliverability of the network is determined by - calculating the deliverability of blocks and considering the relationship between the different blocks. An STBD for the proposed plan, is time-dependent because of uncertainty regarding the travel time. Time-dependent analysis looks at the deliverability of spare parts as a function of time to delivery (*TTD*) and operational conditions. Spare part deliverability in a given network and specific mode of transportation, is a probability that the spare part will be delivered, under a given condition, within an intended planned delivery time.

The spare part deliverability of each mode can be quantified using common probability distribution, such as Weibull distributions, or a covariate model like the proportional hazard model (Kumar and Westberg, 1997). In the common probability distributions the only variable is the time to delivery (*TTD*), but the covariate model can be used to model the effect of operational conditions like snow on the spare part deliverability. In other words, in these models the spare part deliverability will be a function of the time and influence factor. If continuous random variable, T , is the time to delivery of the spare part: $T \geq 0$, then the spare part deliverability using the common probability distribution, $D(t)$, can be expressed as:

$$D(T) = Pr[T \leq t] \quad (1)$$

where, t is the random delivery time, $D(t) \geq 0$, $D(0) = 0$, & $\lim_{t \rightarrow \infty} D(t) = 1$

The spare part deliverability can also be expressed mathematically as:

$$D(t) = \int_0^t f(s) ds \quad (2)$$

where $f(s)$, is a probability density function and t is a continuous random delivery time. In addition, mean time to delivery (*MTTD*), which is a measure of the speed of a given mode of transportation, can be calculated by:

$$MTTD(t) = \int_{-\infty}^{\infty} tf(s) ds \quad (3)$$

To calculate the deliverability of the network or STBD after calculating the spare part deliverability of each mode, the relationship between them needs to be modeled. In general, the main types of configurations used in constructing STBD are series, parallel and combined configurations. These models are discussed below briefly.

2.1. Series Transportation Network

A network can have modes network-wise in series, when the delay or cancellation of any one or more modes results in the delay or cancellation of the entire network (Fig. 1). Note that, below, modes 1, 2, ... mode (n) could be any type of mode of transport such as truck-cargo, air-cargo, etc.

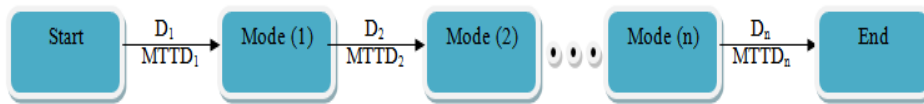

Figure 1. Series spare parts transportation network

Since all of the units in the series need to succeed for a successful mission, the deliverability of the network is the probability that all n modes in the series succeed. The deliverability of series transportation network ($D_{stm}(t)$) is then given by:

$$D_{stm}(t) = \prod_{i=1}^n D_i(t) \quad (4)$$

where, $D_i(t)$ ($i = 1$ to n) is the probability of deliverability for each mode.

2.2. Parallel Transportation Network

A network can also have modes network-wise in parallel (redundancy), when only the delay/cancellation of all the modes in the network results in the delay/cancellation of the overall network (Fig. 2). It must be considered that when there is a parallel configuration, different routes can be selected for transportation. However, these routes do not have the same weight in the decision making process. In order to show this concept, the probability of selecting one mode, P_i from the available mode's needs to be defined, where $0 \leq P_i \leq 1$ and $\sum P_i = 1$. Considering this definition, the deliverability of the parallel transportation network (D_{ptm}) (assuming independence) is then given by:

$$D_{ptm}(t) = 1 - \prod_{i=1}^n (1 - P_i(t)D_i(t)) \quad (5)$$

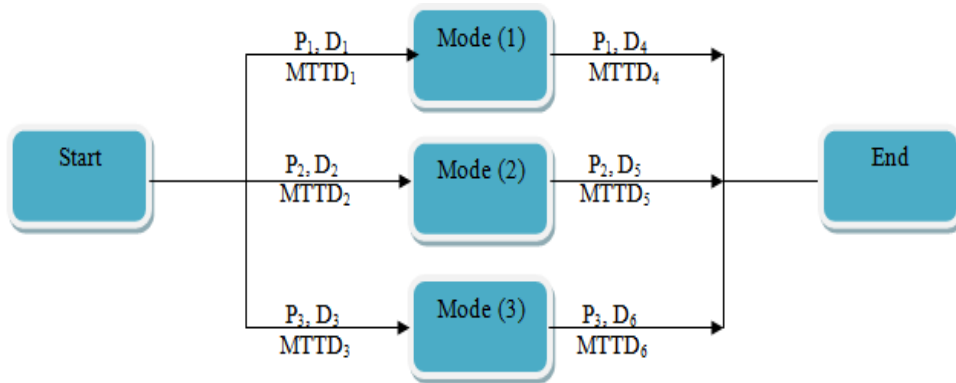

Figure 2. Parallel spare part transportation network

It must be taken into consideration that there are many factors which may have an effect on P_i such as the cost or the reliability of the transportation mode.

2.3. Combined Transportation Network

The Combined Transportation Network is a combination of series and parallel transportation networks (Fig. 3). The deliverability of the combined network is calculated by simplifying or breaking the network down into a series and parallel network. The application of this model is shown by a case study in Section 3.

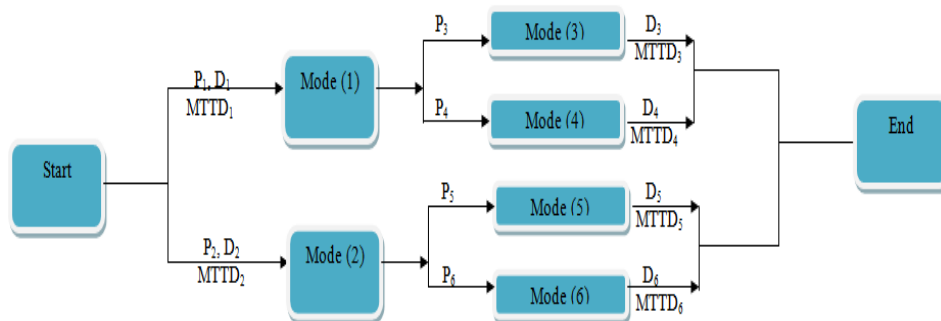

Figure 3. Combined spare part transportation network

3. CASE STUDY: GOLIAT PRODUCTION FACILITY PROJECT, NORWAY

The Goliat FPSO (Floating, Production, Storage and Off-loading) field is the first oil field development project in the Barents Sea. The field is situated off Norway’s northern tip, about 85 kilometers northwest of Hammerfest, in the Barents region. In this section the concept of the spare part transportation block diagram (STBD) will be illustrated for transporting spare parts from the southwestern part of Norway to Goliat FPSO.

3.1. Case Description

For the Goliat FPSO development project, the operator plans to get logistic support from an onshore warehouse located at the Polarbasen, Hammerfest, in the north of Norway and from a manufacturer and supplier’s warehouse located at Dusavika, Stavanger, in the southwest of Norway. Polarbasen, Hammerfest, is the main hub for oil and gas (O&G) related activities in the Barents Sea, and is considered as a hub for operator/ owner spare part warehouses. Dusavika, Stavanger, is considered as a hub for spare part manufacturers and suppliers.

The concept of STDB is applied to estimate the mean time to delivery of the spare part from Dusavika to Goliat FPSO via Polarbasen. In addition, spare part deliverability and overall network spare part deliverability are estimated. Air-cargo, ship-cargo, and truck-cargo, are used to transport the spare part from Dusavika to Polarbasen. Helicopter and ship-cargo are used to transport the spare part from Polarbasen to Goliat FPSO. Figure 4 shows the STBD for Goliat FPSO.

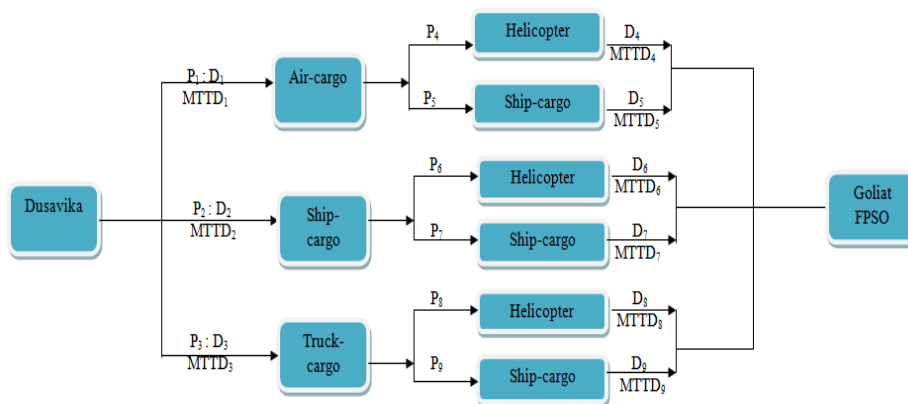

Figure 4. STBD for Goliat FPSO

3.2. Data Collection

The data used in this study have been collected using different sources such as meetings and discussions with shipping agents, email requests, telephone conversations, and using Statens vegvesen route planner – a route planner developed by the Norwegian Public Roads Administration. Transportation times, distance between two transits, and average allowable speed are part of the collected data. For example, if spare part delivery starts from Dusavika (from the manufacturer/supplier's warehouse) at 09:50 (in the morning), it will take approximately 35 min by truck-cargo to the airport and the spare part must be delivered at least 30 min before takeoff, for processing at the airport terminal. Then, if the air-cargo takeoff is at 10:55 (in the morning) -from Stavanger airport, the latest delivery in Polarbasen is at 18:18 (in the evening). From Polarbasen to Goliat FPSO it will take from half an hour to four hours. Therefore, the total approximated travel time for air-cargo is 8 to 13 hours. Table 1 shows a summary of the collected data.

Table 1. Transport mode, distance, and travel time

Transport Mode	Dusavika - Polarbasen		Polarbasen - Goliat FPSO		Total Time (T_T) (hrs)
	Distance (D_1)	Time (T_1) (hrs)	Distance (D_2)	Time (T_2) (hrs)	$T_1 + T_2$
Air-cargo	-	8.0 – 11.5	-	0.5 – 1.5	8.5 – 13.0
Ship-cargo	930 nm	85.0 – 95.0	46 nm	4.5 – 8.0	90.0 – 103.0
Truck-cargo	2392 km	35.0 – 45.0	-	-	35.0 – 45.0

For each transport mode, time to delivery data are collected and estimated for both winter and summer seasons, in order to analyze the effect of operational conditions. In other words, the travel time data are classified into two different groups, winter and summer data, based on the operational conditions. Thereafter, for each group, the analysis has been carried out separately. Table 2 shows an example of sorted *TTD* data for ship-cargo.

Table 2. Examples of *TTD*

Dusavika - Polarbase		Polarbase - Goliat FPSO	
Summer	Winter	Summer	Winter
<i>TTD (hr)</i>	<i>TTD (hr)</i>	<i>TTD (hr)</i>	<i>TTD (hr)</i>
85.0	87.0	5.0	6.0
88.0	88.0	5.0	6.0
88.0	88.0	4.5	6.5
88.5	90.0	5.5	7.0
89.0	92.0	5.5	8.0
90.0	93.0	5.5	7.0
90.0	93.0	5.5	7.0

3.3. Data Analysis

As previously mentioned, in order to consider the effect of operational conditions on the spare part deliverability function, the data have been categorized into - two groups. Moreover, in order to obtain the spare part transportation deliverability, the common distributions have been used and STBD are employed to obtain the network deliverability. The following assumptions have been made, for the data analysis: (1) the weight and size of the spare part are within an acceptable range. Hence, air-cargo, the ship-cargo, and truck-cargo can be used to transport the spare part. (2) The total planned delivery time equals 100 hours (from Dusavika to Polarbase and then to Goliat FPSO).

3.3.1. Spare Part Deliverability Function

In order to find the spare part deliverability function using the common groups in the first stage, some distributions such as normal, log-normal or Weibull need to be nominated for the data. In the next stage using some goodness of fit test, best fit distribution for the data can be found. Then the distribution parameter needs to be calculated using available methods such as maximum likelihood (MLE) methods (Kumar et al., 2000a). In this paper, Weibull ++8 distribution wizard is used as a tool to estimate the best fit distribution for the given data (ReliaSoft, 2013). Then, by implementing the best fit distribution for the given data using MLE, mean time to delivery (*MTTD*) are estimated.

Table 3. Summary of data analysis for different transportation blocks

Transport Mode		Best-fit	$MTT D_1$ (hrs)	Transport Mode	$MTT D_2$ (hrs)	$MTT D_7$ (hrs)
			Dusavika – Polarbasen		Polarbasen – Goliat FPSO	$MTT D_1 + MTT D_2$
Air-cargo	Summer	Log-logistic	8.70	Helicopter	1.30	10.00
				Ship-cargo	5.80	14.50
	Winter	G-Gamma	10.00	Helicopter	2.10	12.10
				Ship-cargo	8.20	18.20
Ship-cargo	Summer	3P-Weibull	90.30	Helicopter	1.30	91.60
				Ship-cargo	5.80	96.10
	Winter	3P-Weibull	94.10	Helicopter	2.10	96.20
				Ship-cargo	8.20	102.30
Truck-cargo	Summer	3P-Weibull	45.60	Helicopter	1.30	46.90
				Ship-cargo	5.80	51.40
	Winter	Exponential	55.80	Helicopter	2.10	57.90
				Ship-cargo	8.20	64.00

As Table 3 shows, the minimum total $MTTD$ is about 10 hours in summer time. However, in the Barents region, during the summer season there is a heavy fog condition which sometimes halts helicopter operation. Thus, in such conditions, the only alternative to transport the spare part from Polarbasen to Goliat FPSO will be ship-cargo, which will increase the minimum $MTTD$ by around 4.5 hours, and in this case the latest delivery will be after around 14.5 hours.

However, according to our assumption the total planned delivery time from Dusavika to Goliat FPSO via Polarbasen is 100 hours. In addition, the probability of using air-cargo to transport the spare part from Dusavika to Polarbasen might not be 1. Thus, it is feasible to consider the other alternatives such as truck-cargo and ship-cargo in order to reduce the cost of transportation. Table 4 shows the probability of the requested spare part arriving at Polarbasen from Dusavika at the end of different time intervals.

Table 4. Deliverability of each block from Dusavika to Polarbasen

Interval Time (hrs)	Air-cargo	Ship-cargo	Truck-cargo
	D(t)	D(t)	D(t)
0	0.00	0.00	0.00
10	0.85	0.00	0.00
20	0.99	0.00	0.00
30	1.00	0.00	0.00
40	1.00	0.00	0.06
50	1.00	0.00	0.84
60	1.00	0.00	0.99
70	1.00	0.00	0.99
80	1.00	0.00	1.00
90	1.00	0.47	1.00
100	1.00	1.00	1.00

For example, within 90 hours we have 47.00% probability of having the requested spare part at Polarbasen, if we use a ship-cargo to transport the spare part from Dusavika. Once the spare part is delivered at Polarbasen then helicopter and ship-cargo can be used to transport the spare part to Goliat FPSO. Table 5 summarizes spare part deliverability from Polarbasen to Goliat FPSO.

Table 5. Deliverability of each block from Polarbasen to Goliat FPSO

Interval Time (hrs)	Helicopter	Ship-cargo
	D(t)	D(t)
0	0.00	0.00
1	0.47	0.00
2	0.85	0.00
3	0.97	0.00
4	0.99	0.00
5	0.99	0.09
6	0.99	0.62
7	1.00	0.96
8	1.00	0.99
9	1.00	1.00
10	1.00	1.00

3.3.2. Network Spare Part Deliverability

As mentioned, in this case study the spare part must first be transported to Polarbasen from Dusavika, then to Goliat FPSO. The maximum *MTTD* from Dusavika to Polarbasen is around 95 hours, and from Polarbasen to Goliat FPSO is around 8 hours. Hence, in order to calculate the deliverability of the system, in the first stage the deliverability of the spare part to Polarbasen from Dusavika within 90 hours, $D_{N1}(t=90hr)$ and the spare part deliverability to Goliat FPSO from Polarbasen within 10 hours, $D_{N2}(t=10hr)$ are estimated. Moreover, after calculating the deliverability of the spare part from Dusavika to Polarbasen and Polarbasen to Goliat, considering the series configuration, the deliverability of the network can be calculated as:

$$D_N(t) = D_{N1}(t) \cdot D_{N2}(t)$$

6)

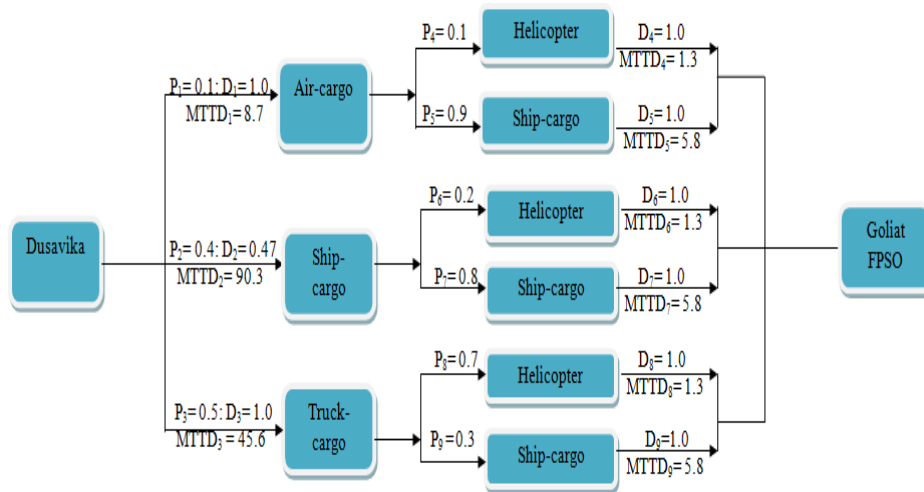

Figure 5. STBD for the Goliat FPSO in summer season

Figure 5 shows the STBD for the case study in the summer; the probability of selecting one mode, P_i and the spare part deliverability (D_i) within the $MTTD$ are shown in this figure. Table 6 shows the result of deliverability analysis for the network in summer and winter.

Table 6. Network spare part deliverability in summer and winter season's

Season of Transport	Dusavika - Polarbasen				Polarbasen - Goliat FPSO				Network Deliverability $D_N = D_{N1} \cdot D_{N2}$
	Mode of Transport	D_{N1}			Mode of Transport	D_{N2}			
		P_i	D_i	$D_{N1}(t=90hr) = P_i \cdot D_i$		P_i	D_i	$D_{N2}(t=10hr) = P_i \cdot D_i$	
Summer	Air-cargo	0.1	1.00	0.10	Helicopter	0.1	1.00	0.10	0.01
					Ship-cargo	0.9	1.00	0.90	0.09
Winter	Air-cargo	0.1	1.00	0.10	Helicopter	0.1	1.00	0.10	0.01
					Ship-cargo	0.9	0.80	0.72	0.07
Summer	Ship-cargo	0.4	0.47	0.19	Helicopter	0.7	1.00	0.70	0.13
					Ship-cargo	0.3	1.00	0.30	0.06
Winter	Ship-cargo	0.4	0.18	0.07	Helicopter	0.7	1.00	0.70	0.05
					Ship-cargo	0.3	0.80	0.24	0.02
Summer	Truck-cargo	0.5	1.00	0.50	Helicopter	0.2	1.00	0.20	0.10
					Ship-cargo	0.8	1.00	0.80	0.40
Winter	Truck-cargo	0.5	1.00	0.50	Helicopter	0.2	1.00	0.20	0.10
					Ship-cargo	0.8	0.80	0.64	0.32

The result of the analysis shows that the most suitable way of transporting the spare parts is using truck-cargo from Dusavika to Polarbasen and ship-cargo from Polarbasen to Goliat FPSO. Moreover, for the summer season, there is a 40% probability of having the spare part at Goliat FPSO within 100 hours, if we use truck-cargo from Dusavika to Polarbasen and ship-cargo from Polarbasen to Goliat FPSO. However, for the winter season, this probability decreased to 32%. This shows that during the winter season the operational conditions of the Arctic region have a significant effect on spare part transportation.

4. CONCLUSION

The results obtained from data analysis showed that the spare part transportation block diagrams (STBD) can be used as tools to analyze different means of transportation connected network-wise considering the operational conditions. STBD can help the user to investigate the appropriate path for the spare part transportation, from manufacturer to on-site or from operator/owner's warehouse to on-site. In addition, STBD is helpful in supporting the user to estimate the probability of having the requested spare part on-site, within the planned delivery time. In the case study, comparing the network deliverability of the summer and winter seasons shows that there are approximately 20% extended delay's during the winter season due to the operational conditions. Hence, any decision about the transportation of spare parts in the Arctic region must consider the effects of the operational conditions of the region.

REFERENCES

- Barabadi, A. 2012. Reliability and Spare Parts Provision Considering Operational Environment: A Case Study. *International Journal of Performability Engineering*, 8, 497.
- Barabadi, A., Barabady, J. & Markeset, T. 2009. Management of Production Assurance in Harsh, Remote, and Sensitive Environment. *The Proceedings of the 20th International Conference on Port and Ocean Engineering under Arctic Conditions (POAC2009)*.
- Barabadi, A., Ghodrati, B., Barabady, J. & Markeset, T. 2012. Reliability and Spare Parts Estimation Taking into Consideration the Operational Environment - A Case Study. *IEEE Press*.
- Gao, X., Barabady, J. & Markeset, T. 2010. An Approach for Prediction of Petroleum Production Facility Performance Considering Arctic Influence Factors. *Reliability Engineering & System Safety*, 95, 837-846.
- Gao, X., Markeset, T. & Kumar, U. 2007. A Review of Production Assurance in the Norwegian Petroleum Industry. *Proceedings of the Seventh International Conference on Reliability, Maintainability and Safety*.
- Ghodrati, B. 2006. Weibull and Exponential Renewal Models in Spare Parts Estimation: A Comparison. *International Journal of Performability Engineering*, 2, 135.
- Gudmestad, O., Alhimenko, A., Løset, S., Shkhinek, K., Tørum, A. & Jensen, A. 2007. Engineering Aspects Related to Arctic Offshore Developments. *Student's Book for Institutes of Higher Education*, St. Petersburg Publisher.
- Gudmestad, O. T. & Strass, P. 1994. Technological Challenges for Hydrocarbon Production in the Barents Sea. *Power Technology and Engineering (formerly Hydrotechnical Construction)*, 28, 460-471.
- Hasle, J. R., Kjellen, U. & Haugerud, O. 2009. Decision on Oil and Gas Exploration in an Arctic Area: Case study from the Norwegian Barents Sea. *Safety Science*, 47, 832-842.

Kayrbekova, D., Barabadi, A. & Markeset, T. 2011. Maintenance Cost Evaluation of a System to be Used in Arctic Conditions: A Case Study. *Journal of Quality in Maintenance Engineering*, 17, 320-336.

Kumar, D. & Westberg, U. 1997. Some Reliability Models for Analyzing the Effect of Operating Conditions. *International Journal of Reliability, Quality and Safety Engineering*, 4, 133-148.

Kumar, U., Crocker, J., Knezevic, J. & El-Haram, M. 2000. Reliability, Maintenance and Logistic Support: A Life Cycle Approach. New York: Kluwer Academic Publishers.

ReliaSoft. 2007. User's Guide Blocksim 7. ReliaSoft Institution. USA.

Stefanusen, T. 2012. Spare Parts Management in the Barents Sea. Master Degree Thesis, University of Tromsø.

Paper II

Ayele Y.Z. , Barabadi, A (2013). Dynamic Spare Part Transportation Block Diagram.

To be submitted to International Journals

Dynamic Spare Part Transportation Block Diagram

Ayele, Y.Z. , Barabadi, A.

University of Tromsø, N-9037 Tromsø, NORWAY

ABSTRACT

The complex operational condition of the Arctic region can increase the challenges related to the spare part planning, especially the transportation of spare parts in the region. In addition, the Arctic region provides a dynamic operational condition with respect to transportation time. Hence, a system which intends to create a productive spare part transportation management with an appropriate consideration of the dynamic behavior of the Arctic region is the suitable approach. In this paper we develop the concept of dynamic spare part transportation block diagram (DSTBD) for possible transportation modes and routes. Furthermore, the factors which provide dynamic behavior of a spare part transportation network such as season (months) of the year (i.e. to transport the spare part), and criticality of the spare part are modeled.

Keywords: Spare part, Dynamic network, Transportation, Block diagram, Deliverability

1. INTRODUCTION

Estimates which indicate a large share of the world's undiscovered oil and gas resources is to be found in the Arctic areas and the increasing demand for energy are important reasons for the growing interest in the Arctic region. Challenging operational conditions of the Arctic region (such as deeper water, remote locations, harsh environments, and a complex operational condition the hazards) are expected to increase significantly environmental degradation, equipment damages, workplace injuries and system failures associated with these projects compared to the well-established practices of exploration and production such as Norwegian continental shelf (Gudmestad et al., 2007, Barabadi et al., 2009, Gudmestad and Strass, 1994, Kayrbekova et al., 2011).

In order to meet the availability target and to reduce downtime, effective maintenance management and maintenance support services are undoubtedly important. Spare parts planning and management as an important aspect of maintenance support services assure the availability of spare parts upon demand. The availability of spare parts decreases the production down-time and increases the utilization of the system/machine and consequently the profitability of the project (Ghodrati, 2005). The objective of effective spare part planning and management are: to relate spare part stock and store quantities to demand; to avoid losses due to spoilage, pilferage and obsolescence; to obtain the best turnover rate on all spare part items by considering both the cost of acquisitions and possessions (Markeset, 2011).

In order to achieve a cost-effective spare parts planning and management estimation of the transportation and probability of transporting within a specific time play a crucial role. However, beyond the usual factors, challenges, and conditions met by oil and gas industries, located around the world, the oil and gas industries in the Arctic region have a magnified challenges, risks and complications related to spare parts logistics and transportation. This could mainly due to the remoteness of the location, the demanding physical conditions of the Arctic, and the vulnerability of the Arctic wilderness. Hence, modifying and/or developing new and emerging transportation model by considering the effect of operating conditions of the Arctic region, can offer solutions to fill the gaps which exist between the present practices and future needs.

Arctic conditions provide a dynamic operational condition with respect to transportation time. For example, sea icing and foggy conditions can cause a delay and/or extended period of transportation. Ayele et al. (2013) has studied the spare part transportation block diagram to estimate the mean time to delivery and the probability of deliverability for the Arctic conditions. However, they didn't discuss about the dynamic behavior of the transportation model. In addition, there are a significant number of literatures to investigate the dynamic behavior of the transportation network. Guo and Liu (2011) proposed a day-to-day dynamic model which is suitable for the discrete/continuum representation of transportation networks. Yerra and Levinson (2005) considered the dynamics of the orientation of major roads in a network and proposed models to understand the basic properties of transportation networks. Li et al (2008) studied the dynamics of the user's day-to-day route adjustment process in the general transportation network. For example, Li et al (2008) proposed a model that combines a supply model that simulates the time-dependent attributes of roads and their variations with a demand model that simultaneously considers heterogeneous users' choices on departure time, and route.

However, most of the literatures didn't thoroughly discuss the effects of dynamic behavior of the transportation network related to spare parts planning and management. These issues could affect the estimation of time to delivery of the spare part and the probability of having the spare part within intended time. Hence, ignoring the effect of the dynamic behavior of the transportation network and using the conventional methods may increase the uncertainty and lead to inaccurate results. Therefore, spare parts transportation management plan, that consider the dynamic behavior of the transportation network and the operational conditions of the Arctic region is very crucial.

The aim of this paper is to introduce the concept of the dynamic spare part transportation block diagram (DSTBD) for possible transportation routes and mode of transportation to facilitate the spare part planning and management process. In this model, the factors which provide dynamic behavior of a spare part transportation network such as season (months) of the year (i.e. to transport the spare part), and criticality of the spare part are modeled.

The model helps users to predict the probability of choosing one mode from available choices, to estimate the mean time to delivery of spare parts, and also to estimate the probability of having the requested spare part on-site within the planned delivery time, considering the operational conditions. The rest of the paper is organized as follows: Section 2 discusses the concept overview of the dynamic behavior of the transportation network. Section 3 introduces the DSTBD model. Section 4 presents a description of the case study and the application of the DSTBD model. Section 5 provides the conclusion.

2. CONCEPT OVERVIEW: DYNAMIC TRANSPORTATION NETWORK

A transportation network, is typically a network of roads, streets, canals, airports or nearly any structure which permits either vehicular movement or flow of some cargoes. It may combine different modes of transport, for example, air-cargo and truck-cargo to model multi-modal networks. Finding an appropriate path and suitable mode of transport in a both dynamic and time-dependent network is currently regarded as the most difficult task in the route finding problems (Loui, 1983). The dynamicity of transport networks result from various sources, which range from irregular and random incidents, such as traffic accidents, vehicle/air-cargo/ship-cargo breakdowns, road works, signal failures, adverse weather condition, to regular fluctuations in travel demand and capacity by time of day, day of the week, and season (Taylor, 1999, Bates et al., 2001, Chen et al., 2002, Li et al., 2008). Hence, in order to have a precise estimate of transportation time and its related probability, the dynamic behavior of the network must be taken into consideration. In addition, the Arctic is characterized by extreme cold, varying forms and amounts of sea ice, seasonal darkness, high winds, polar lows, and extended periods of heavy fog, all of which can be a source of the dynamicity the transportation network of the spare parts (Gudmestad et al., 2007, Barabadi et al., 2009, Gudmestad and Strass, 1994, Kayrbekova et al., 2011, Gao et al., 2010, Hasle et al., 2009).

In general the main factors which provide a dynamic behavior of the system under the arctic condition are the criticality of the components, and climate conditions.

In order to include the dynamic behavior and to model spare part dynamic transportation block diagram, firstly we need to define a function that can predict the outcome of a dependent variable based on one or more predictor variable. In this paper, multinomial logistic regression is used to predict the outcome of a categorical dependent variable. The probabilities describing the possible outcome of a single trial are modelled, as a function of explanatory variables, using a logistic function.

As an example, consider a transportation of spare part where the choice is between an air-cargo, a ship-cargo, and a truck-cargo. We would then use four latent variables (based on criticality hierarchy), one for each choice. Then, in accordance with utility theory (Marshall, 1920), we can then interpret the latent variables as expressing the utility that results from making each of the choices. A spare part planning manager might expect that using of the air-cargo would have less mean time to delivery. This would reduce the extended down-time due to un-deliverability of the spare part but increase the cost of transportation, and this would cause moderately high benefit (i.e. utility increase). On the other hand, using of the cargo-ship might be expected to reduce the transportation costs but increase the downtime (i.e. utility decrease). Finally, using the truck-cargo would might have some medium effect on the transportation cost and can reduce extended down-time (i.e. moderate utility increase). Thus, selecting one mode from a given choice might result increased, decreased or moderate utility. This can be interpreted (expressed) as a probability of selecting one mode, P_i from the available mode's, where $0 \leq P_i \leq 1$ and $\sum P_i = 1$ (this concept will be discussed in detail in Section 3). Table 1 shows the estimated strength of regression coefficients for different outcomes (mode choices) and different values of explanatory variables. Hassen et al (2012) categorized spare part, based on the estimated risk as: high critical, medium high critical, medium critical, and low critical. We used this hierarchy, as our latent variables for each mode choice.

Table 1: Strength of regression coefficient (mode vs criticality)

Criticality \ Mode	Air-cargo	Ship-cargo	Truck-cargo
High	Strong +	Strong -	Medium strong -
Medium High	Medium strong +	Moderate -	Moderate -
Medium	Moderate +	Moderate +	Moderate +
Low	Weak +	Strong +	Strong +

Table 1 describes that separate sets of regression coefficients need to exist for each choice. Different mode choices have different effects on net utility; furthermore, the effects vary in complex ways that depend on the characteristics of the spare part (i.e. based on criticality), so there need to be separate sets of coefficients for each characteristic, not simply a single extra per-choice characteristic. Even though criticality is a continuous variable, its effect on utility is too complex for it to be treated as a single variable. Thus, it needs to be directly split up into ranges, such as high, medium high, medium, and low.

In addition to the criticality factor there are other factors which can be sourced for the dynamic behavior of the network, such as climatic condition, type/size of spare part, packing cost, and location of consignor and consignee. For example, the formation of fog is one of the major causes that could halt the operation of the air-cargo and helicopter, in the Arctic region. Thus, the fog can act as a latent variable, and it might result different utility effect from making each of the choices. Table 2 shows the estimated strength of regression coefficients for different outcomes (mode choices) and different values of explanatory variables.

Table 2: Strength of regression coefficient for air-cargo (mode vs month)

Month \ Mode	Air-cargo				
	Fog	No fog			
		H	MH	M	L
January	Strong -	Strong +	Medium strong +	Moderate +	Weak +
February	Strong -	Strong +	Medium strong +	Moderate +	Weak +
March	Strong -	Strong +	Medium strong +	Moderate +	Weak +
April	Strong -	Strong +	Medium strong +	Moderate +	Weak +
May	Strong -	Strong +	Medium strong +	Moderate +	Weak +
June	Strong -	Strong +	Medium strong +	Moderate +	Weak +
July	Strong -	Strong +	Medium strong +	Moderate +	Weak +
August	Strong -	Strong +	Medium strong +	Moderate +	Weak +
September	Strong -	Strong +	Medium strong +	Moderate +	Weak +
October	Strong -	Strong +	Medium strong +	Moderate +	Weak +
Novemeber	Strong -	Strong +	Medium strong +	Moderate +	Weak +
December	Strong -	Strong +	Medium strong +	Moderate +	Weak +

3. DYNAMIC SPARE PART TRANSPORTATION MODEL, DSTBD

The dynamic spare part transportation model proposed in this paper is based on the fundamental concept of dependency. The dependency in this respect is the dynamic relationship between transportation mode choices, criticality of the spare part, and season (months) of the year (i.e. to transport the spare part). A dependency can be considered as a cause/effect relationship (Distefano and Puliafito, 2009). The cause of a dependency is referable to the occurrence of a specific event, and the effect can be referable as a specific reaction (Distefano and Puliafito, 2009). For example, if we want to transport spare part with high criticality, then the probability of using air-cargo will be higher (if the weather condition allows). In this case, the cause is the high criticality of the spare part, and the effect is choosing an air-cargo.

There are many techniques to predict the outcome of a dependent variable based on one or more predictor variable, such as logistic regression, probit model, multinomial logit, multinomial probit, mixed logit, and etc. (McFadden and Train, 2000, Vovsha, 1997, Train, 1978, Train, 1985, Bekhor et al., 2002, Ramming, 2001, Cascetta et al., 1996, Chu, 1989). In this paper, we used a multinomial logistic regression model - a regression model which generalizes logistic regression by allowing more than two discrete outcomes (Greene and Zhang, 1997). In other word, it is a model that is used to predict the probabilities of the different possible outcomes (mode choices) of a categorically distributed dependent variable, given a set of independent variables (which may be the weather condition, the risk associated with the un-deliverability of the spares, planned delivery time, etc.).

3.1. Mathematical Background

The first step in the proposed model is to develop logistic function, in order to estimate the probabilities of the different mode choices based on latent variables (such as criticality hierarchy, fog condition, snow condition, and etc.). Multinomial logistic regression is used when the dependent variable in question is nominal (equivalently categorical, meaning that it falls into any one of a set of categories which cannot be ordered in any meaningful way) and for which there are more than two categories.

For example, which mode of transport will be chosen, given that the required spare part has a medium high criticality, no fog condition, and some specific amount of transportation cost etc.? In addition, multinomial logistic regression assumes a linear combination of the given requirement (such as the weather condition, criticality, and etc.), to determine the probability of each particular outcome of the dependent variable (the outcome might be using air-cargo, ship-cargo, or truck-cargo). When, the multinomial logistic is used to model choices, it depends on the assumption of independence of irrelevant alternatives (IIA) (Train, 1978). This assumption states that the odds of preferring one mode of transport over another do not depend on the presence or absence of other "irrelevant" alternatives (Train, 1978).

In general form, the probability that mode i to be chosen from n alternatives is expressed as:

$$P_i \equiv \text{Prob}(\text{mode } i \text{ to be chosen from } n \text{ alternatives}) \\ = G(x_{in}, x_{jn} \forall j \neq i, s_n, \beta) \quad (1)$$

where x_{in} is a vector of attributes of alternative n , $x_{jn} \forall j \neq i$ is a vector of attributes of the other alternatives (other than n), s_n is a vector of characteristics (criticality) of the item, and β is a set of parameters that relate variables to probabilities, which are estimated statistically.

In our case, the attributes of modes (x_{in}), can be the average travel time and cost of transportation, and the characteristics of the spare part (s_n), can be the criticality of the spare part (high/medium high/medium/low criticality), and this can be used to calculate the probabilities of the choices. The attributes of the alternatives can differ over mode (s); e.g., cost and time for travel from southwestern Norway to northern Norway by truck-cargo, air-cargo, and ship-cargo are different. The basic properties of the probability that mode i to be chosen from n alternatives is: $0 \leq P_i \leq 1$ and $\sum_{k=1}^K P_k = 1$, where K is the total number of alternatives (mode of transport).

Furthermore, we can have the utility U_{ni} (or net benefit) that the company n obtains from choosing mode i . The characteristic (criticality) of the spare part can be the utility-maximizing i.e. the company n will chooses the alternative that provides the highest utility.

The choice of the company can be designated by dummy variables, y_{ni} , for each mode:

$$y_{ni} = \begin{cases} 1, & \text{if } U_{ni} > U_{nj} \quad \forall j \neq i \\ 0, & \text{otherwise} \end{cases} \quad (2)$$

The probability that a company chooses a particular mode of transport is determined by comparing the utility of choosing that mode (e.g. air-cargo) to the utility of choosing other alternatives (e.g. truck-cargo or ship-cargo). This can be expressed as:

$$P_i = \text{Prob} (y_{ni} = 1) \quad (3)$$

$$= \text{Prob} (U_{ni} > U_{nj}, \quad \forall j \neq i) \quad (4)$$

$$= \text{Prob} (U_{ni} - U_{nj} > 0, \quad \forall j \neq i) \quad (5)$$

In general, the basic idea of logistic regression is to use the mechanism which is already developed for linear regression by modeling the probability P_i using a linear predictor function – a linear function of a set of coefficients and explanatory variables (such as presence of fog, criticality, risk of un-deliverability,...), whose value is used to predict the outcome (mode choice) of a dependent variable. The linear predictor function $f(i)$ can be written as:

$$f(i) = [\beta_0 + \dots + \beta_i x_i] + [\delta_0 + \dots + \delta_j x_j(t)] \quad (6)$$

where β_i and δ_j are regression coefficient indicating the relative effect of a particular explanatory variable on the outcome, x_i are explanatory variables for time independent covariates, and $x_j(t)$ are explanatory variables for time-dependent covariates. Then, by grouping the regression coefficient and the explanatory variables, the linear predictor function can be re-written as follows:

$$f(i) = \sum_{i=0}^k \beta_i x_i + \sum_{j=0}^m \delta_j x_j(t) \quad (7)$$

The probability that mode i to be chosen from n alternatives can be expressed mathematically as:

$$P_i = \frac{1}{1 + \exp[\sum_{i=0}^k \beta_i x_i + \sum_{j=0}^m \delta_j x_j(t)]} \quad (8)$$

3.2. Dynamic Spare part Transportation Block Diagram

In general, after the estimation of the probability of selection of each mode of transportation from available alternatives, the next step is to estimate the spare part dynamic deliverability. Spare part dynamic deliverability, in a given dynamic network and specific mode of transportation, can be defined as a probability that the spare part will be delivered, under a given condition, within an intended planned delivery time. In order to estimate the spare part dynamic deliverability and to consider the dynamic behavior of the network, in this paper we develop spare part dynamic transportation block diagram (DSTBD). The initial idea for the model comes from the dynamic reliability block diagram (DRBD), which is used in reliability engineering in order to calculate the reliability of the dynamic system (Distefano and Puliafito, 2009).

The DSTBD is a specialized type of flowchart which presents the function of a dynamic transportation network systems, as well as the relationships and interface involved between different mode of transportation. In addition, DSTBD consist an input point (starting point), an output point (ending point), and a set of blocks. Each block represents a transportation mode, like air-cargo, that functions correctly (Steffanusen, 2012). The block diagram shows how blocks (modes of transportation) are connected together and is used to facilitate understanding of the complete array of modes of transportation by breaking them down into the most dominant modes (air, land, and water) (Steffanusen, 2012).

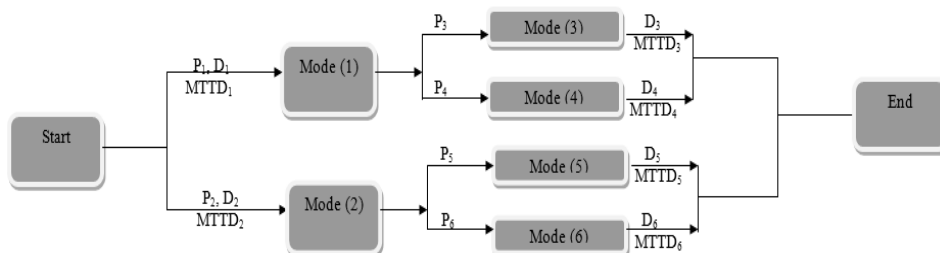

Figure 2: Combined dynamic spare part transportation network

The DSTBD is used to consider the dynamicity of transport networks, and to measure how probable it is to have the spare part on-site (within the planned delivery time). The DSTBD, is dynamic and time-dependent network, this is due to the dependency of the dynamic relationship between the probability that mode i to be chosen from n alternatives (P_i), the effect of time-dependent covariates, and the uncertainty regarding the travel time. Dynamic and time-dependent analysis looks at the spare parts dynamic deliverability as a function of time to delivery (TTD) and operational conditions (covariates).

The spare part dynamic deliverability of each mode can be quantified using a covariate model, such as the proportional hazard model (PHM) (Kumar and Westberg, 1997, Cox, 1972). However, the main assumption in PHM is that the effect of covariates is time-independent; therefore, this model is not applicable for estimating the spare parts dynamic deliverability, which is time-dependent. The time-dependency of covariates such as fog condition, snow and ice condition and etc. could have a direct effect on the choice of mode of transportation and time to delivery. Thus, in this paper we use the extension of PHM, in order to consider time-dependent covariates, while we model the DSTBD. In other words, in our model the spare part dynamic deliverability will be a function of the time and influence factor. If continuous random variable, T , is the time to delivery of the spare part: $T \geq 0$, then the spare part deliverability using the common probability distribution, $D_0(t)$, can be expressed as:

$$D_0(t) = Pr[T \leq t] \quad (9)$$

where, t is the random delivery time, $D_0(t) \geq 0$, $D_0(0) = 0$, and $\lim_{t \rightarrow \infty} D_0(t) = 1$

The spare part deliverability can also be expressed mathematically as:

$$D_0(t) = \int_0^t f(s) ds \quad (10)$$

where, $f(s)$ is a probability density function and t is a continuous random delivery time.

However, equation (10) and (11) didn't consider the effects of covariates. Thus, in the presence of time-dependent covariates, the extension of PHM can be used (Barabadi, 2012). Hence, the spare part dynamic deliverability, by using the extension of PHM, can be expressed as:

$$D(t,z) = 1 - [(1 - D_0(t)) \exp [\sum_{i=1}^n \beta_i z_i + \sum_{j=1}^m \delta_j z_j(t)]] \quad (11)$$

where β_i and δ_j are column vectors consisting of the regression parameters, z_i is a time-independent covariate and $z_j(t)$, is a time-dependent covariate, n is the number of time-independent covariates and m is the number of time-dependent covariates. The method of maximum likelihood can be applied for estimation of β_i and δ_j (Barabadi, 2012). The most difficult and demanding task, in equation (12), is finding the appropriate function for time-dependent covariate, $z_j(t)$ (Barabadi et al., 2011a).

The time-dependent covariate is a covariate which is not necessarily constant throughout the whole season of the year. For instance, if one spare part planning manager wishes to examine the link between the fog condition and the operation of an air-cargo (helicopter), this would be complicated by the fact that the formation of the fog is varied throughout the season. The fog condition could then be introduced in the PHM as a time-varying covariate. Kalbfleisch & Prentice (2002) proposed the Stratification approach and distinguished between external and internal time-dependent covariates. Lloyd D. F. and Lin D. Y. (1999), developed time-dependent covariates in the Cox proportional-hazards regression model. Let T be the time to delivery (arrival time), and let Z be a set of possibly time-dependent covariates. We use $Z(t)$ to denote the value of Z at time t , and $Z(t) = [Z(s) : 0 \leq s \leq t]$ to denote the history of the covariates up to time t . It is convenient to formulate the effects of covariates on the time to delivery through the arrival rate function – a function that supports its user to estimate the effect of the covariates, on the probability of having the requested spare part on-site, within planned delivery time. By using the extension of Lloyd D. F. and Lin D. Y. (1999) model, the conditional-arrival rate function of T given Z , can be written as:

$$A(t | Z) = Pr (T \in [t, t+dt) | T \geq t, Z(t)] \quad (12)$$

where $(t, t + dt)$ is a small interval from t to $t + dt$.

Then, by extending the PHM, the conditional-arrival rate can be expressed as:

$$A(t | Z) = A_0(t) e^{\beta' z(t)} \quad (13)$$

where β is a set of unknown regression parameters, $A_0(t)$ is an arrival rate function (when all covariates are summed to be zero), and $z(t)$ to denote the value of z at time t . The estimation of β can be based on the partial likelihood score function (Fisher and Lin, 1999).

4. CONCLUSION

DSTBD can help the user to investigate the appropriate path for the spare part transportation, by considering the dynamic behavior of the transportation network which is caused by the operational condition of the Arctic region. In addition, DSTBD is helpful in supporting the user to estimate the dynamic probability of having the requested spare part on-site, by considering the influence factors (covariates). However, the proposed models must be tested through replication of findings in more case studies.

5. REFERENCES

Ayele, Y.Z. , Barabadi, A. and Markeset, T. 2012. Spare Part Transportation Management in the High North, *Submitted to Proceedings of the 22nd International Conference on Port and Ocean Engineering under Arctic Conditions*.

Barabadi, A. 2012. Reliability and Spare Parts Provision Considering Operational Environment: A Case Study. *International Journal of Performability Engineering*, Vol 8, 497.

Barabadi, A., Barabady, J. & Markeset, T. 2009. Management of Production Assurance in Harsh, Remote, and Sensitive Environment. *The Proceedings of the 20th International Conference on Port and Ocean Engineering under Arctic Conditions (POAC2009)*.

-
- Barabadi, A., Barabady, J. & Markeset, T. 2011. Maintainability Analysis Considering Time-dependent and Time-independent Covariates. *Reliability Engineering & System Safety*, Vol 96, 210-217.
- Barabadi, A., Ghodrati, B., Barabady, J. & Markeset, T. 2012. Reliability and Spare Parts Estimation Taking into Consideration the Operational Environment - A Case Study. *IEEE Press*.
- Bates, J., Polak, J., Jones, P. & Cook, A. 2001. The Valuation of Reliability for Personal Travel. *Transportation Research Part E: Logistics and Transportation Review*, Vol 37, 191-229.
- Bekhor, S., Ben-Akiva, M. E. & Scott Ramming, M. 2002. Adaptation of Logit Kernel to Route Choice Situation. *Transportation Research Record: Journal of the Transportation Research Board*, Vol 1805, 78-85.
- Cascetta, E., Nuzzolo, A., Russo, F. & Vitetta, A. A Modified Logit Route Choice Model Overcoming Path Overlapping Problems: Specification and Some Calibration Results for Interurban Networks. *Proceedings of the 13th International Symposium on Transportation and Traffic Theory, 1996. Lyon, France, Elsevier Science, 697-711.*
- Chen, A., Yang, H., Lo, H. K. & Tang, W. H. 2002. Capacity Reliability of a Road Network: An Assessment Methodology and Numerical Results. *Transportation Research Part B: Methodological*, Vol 36, 225-252.
- Chu, C. A Paired Combinatorial Logit Model for Travel Demand Analysis. *Transport Policy, Management & Technology Towards 2001: Selected Proceedings of the Fifth World Conference on Transport research, 1989.*
- Cox, D. R. 1972. Regression Models and Life-tables. *Journal of the Royal Statistical Society. Series B (Methodological)*, 187-220.
- Distefano, S. & Puliafito, A. 2009. Reliability of Dependent-Dynamic Systems.

Fisher, L. D. & Lin, D. 1999. Time-dependent Covariates in the Cox Proportional-hazards Regression Model. *Annual Review of Public Health*, Vol 20, 145-157.

Ghodrati, B. 2005. Reliability and Operating Environment Based Spare Parts Planning. *Division of Operation and Maintenance Engineering, Luleå University of Technology*.

Greene, W. H. & Zhang, C. 1997. *Econometric Analysis*, Prentice Hall Upper Saddle River, NJ.

Gudmestad, O., Alhimenko, A., Løset, S., Shkhinek, K., Tørum, A. & Jensen, A. 2007. Engineering Aspects Related to Arctic Offshore Developments. *Student's Book for Institutes of Higher Education, St. Petersburg Publisher*.

Gudmestad, O. T. & Strass, P. 1994. Technological Challenges for Hydrocarbon Production in the Barents Sea. *Power Technology and Engineering (formerly Hydrotechnical Construction)*, Vol 28, 460-471.

Guo, X. and Liu H.X. 2011. A Day-to-Day Dynamic Model in Discrete/Continuum Transportation Networks.

Hassan, J., Khan, F. & Hasan, M. 2012. A Risk-based Approach to Manage Non-repairable Spare Parts Inventory. *Journal of Quality in Maintenance Engineering*, Vol 18, 344-362.

Kayrbekova, D., Barabadi, A. & Markeset, T. 2011. Maintenance Cost Evaluation of a System to be used in Arctic Conditions: A Case Study. *Journal of Quality in Maintenance Engineering*, Vol 17, 320-336.

Kumar, D. & Westberg, U. 1997. Some Reliability Models for Analyzing the Effect of Operating Conditions. *International Journal of Reliability, Quality and Safety Engineering*, Vol 4, 133-148.

Li, Z.-C., Lam, W. H., Wong, S., Huang, H.-J. & Zhu, D.-L. 2008. Reliability Evaluation for Stochastic and Time-dependent Networks with Multiple Parking Facilities. *Networks and Spatial Economics*, Vol 8, 355-381.

Loui, R. P. 1983. Optimal Paths in Graphs with Stochastic or Multidimensional Weights. *Communications of the ACM*, Vol 26, 670-676.

Markeset, T. 2011. PG430 - Operation of Process Plants - "Operations and Maintenance Management"

Marshall, A. 1920. Principles of Economics, An Introductory Volume.

McFadden, D. & Train, K. 2000. Mixed MNL Models for Discrete Response. *Journal of Applied Econometrics*, Vol 15, 447-470.

Ramming, M. S. 2001. *Network Knowledge and Route Choice*. Massachusetts Institute of Technology.

Steffanussen, T. 2012. *Spare Parts Management in the Barents Sea*. Master Degree Thesis, University of Tromsø.

Taylor, M. A. 1999. Dense Network Traffic Models, Travel Time Reliability and Traffic Management. II: Application to Network Reliability. *Journal of Advanced Transportation*, Vol 33, 235-251.

Train, K. 1978. A Validation Test of a Disaggregate Mode Choice Model. *Transportation Research*, Vol 12, 167-174.

Train, K. 1985. Qualitative Choice Analysis: Theory, Econometrics, and an Application to Automobile Demand, MIT press.

Vovsha, P. 1997. Application of Cross-nested Logit Model to Mode Choice in Tel Aviv, Israel, Metropolitan Area. *Transportation Research Record: Journal of the Transportation Research Board*, Vol 1607, 6-15.

Yerra, B. M. and Levinson D. M. 2005. The Emergence of Hierarchy in Transportation Networks. *The Annals of regional Science*.